



HASTINGS
Technology Metals Limited

APPENDIX 5-8
Radiation Management Plan



HASTINGS
Technology Metals Limited

15 December, 2016

Radiation Management Plan

Revision 0

COMPLETED BY: DEAN CROUCH
15/12/2016



RHSS
RESOURCES HEALTH AND SAFETY SERVICES

TABLE OF CONTENTS

1	Introduction	5
1.1	Proponent & Mine Operator	5
1.2	Scope of Plan	5
1.3	Project Overview	6
1.4	Compliance.....	7
2	Regulatory framework	8
2.1	Yangibana Rare Earth Element Project	8
2.2	Mines Safety and Inspection Act, 1994.....	8
2.3	Mines Safety and Inspection Regulations, 1995 Part 16.....	9
2.4	Radiation Safety Act, 1975.....	9
2.5	MoU between Radiological Council & Dept of Mines and Petroleum	10
2.6	ARPANSA.....	10
2.7	Purpose of the Radiation Mangement Plan.....	10
3	Yangibana Operation Description	11
3.1	Environment.....	11
3.2	Geology.....	11
3.3	Workforce.....	11
3.4	Continued Exploration Activities.....	11
3.5	Construction Activities.....	11
3.6	Commissioning Activities.....	12
3.7	Mining & Hauling Operation	12
3.8	Beneficiation & Hydrometallurgy.....	12
3.9	Tailing Storage.....	13
3.9.1	TSF 1.....	14
3.9.2	TSF 2	14
3.9.3	TSF 3	14
3.10	Product Storage	14
3.11	Product Transport.....	14
4	Sources and Pathways of Radiation EXposure.....	16
4.1	Radiation Basics	16
4.2	Radiation Impact Assessment.....	16
4.3	Material Characteristation	17

4.4	Workforce	18
4.5	Critical Groups	19
5	Radiation Exposure Controls & Methodologies	20
5.1	Radiation Protection Standards.....	20
5.1.1	Exposure Standards	20
5.1.2	Contamination Standards.....	20
5.1.3	Competent Personnel.....	20
5.1.4	Compliance with Sampling Standards	20
5.2	Training & Induction.....	20
5.2.1	All Workers to Site	20
5.2.2	Controlled and Restricted Areas.....	21
5.2.3	Radiation Safety Officer and Deputies	21
5.3	Classification of Workplaces	21
5.3.1	Supervised Areas.....	22
5.3.2	Controlled Areas	22
5.3.3	Restricted Areas	22
5.4	Similar Exposure Groups (SEGs).....	23
5.5	Work Permits.....	23
5.6	Dust Suppresion	24
5.7	Housekeeping.....	24
5.8	Personal Hygiene.....	24
5.9	Surface Contamination Control	25
5.10	Signage.....	25
5.10.1	Supervised Area Signage	26
5.10.2	Controlled Area Signage.....	26
5.10.3	Restricted Area Signage.....	27
6	Radiation Monitoring Program	28
6.1	Occupational Radiation Exposure Program	28
6.1.1	External Exposure to Gamma Radiation.....	28
6.1.2	Dust Monitoring.....	28
6.1.3	Internal Radiation Exposure - Radon and Thoron	28
6.1.4	Surface Contamination Monitoring.....	28
6.2	Environmental Radiation Exposure Program	28

6.2.1	Environmental Gamma-Radiation Surveys	29
6.2.2	Dust Monitoring.....	29
6.2.3	Ground Water Monitoring.....	29
6.3	Radiation Monitoring Resources	29
7	Record Keeping & Reporting Standards.....	30
7.1	Records.....	30
7.2	Occupational Radiation Exposure Annual Report	30
7.3	Environmental Radiation Annual Report.....	30
7.4	Investigation and Action Thresholds.....	30
8	Transport of Product.....	31
8.1	General radiation Exposure Scenario	31
8.2	U (nat) & Th (nat) Exemption.....	31
9	Radioactive Waste Management Plan (Tails Storage)	33
10	References	34
11	Glossary	35
12	Commitments (Radiation Safety Policy)	36
12.1	Pre-operational Transport Baseline Survey.....	36
12.2	Review of RMP	36
12.3	Restricted Area and Permit to Work.....	36
12.4	Record Keeping	36
12.5	Radiation Safety Review & Reporting.....	36
12.6	Radiation Monitoring.....	37
12.7	Review of RMP Assumptions.....	37
12.8	Contamination control.....	37
12.9	Stormwater Management.....	37
Appendix 1.	Subsidiary Procedures and Forms.....	38
Appendix 2.	Investigation and Action Limits	39
Appendix 3.	Proposed Supervised and Controlled Areas	40
Appendix 4.	Technical Note: Environmental Summary	41
Appendix 5.	Technical Note: Geological Summary.....	42
Appendix 6.	Radiation Waste Management Plan	43

1 INTRODUCTION

1.1 PROPONENT & MINE OPERATOR

Principle Employer: **Hastings Technology Metals Ltd**
(as per MSIA s4)

Hastings Technology Metals Ltd
Suite 2508, Level 25 St Martins Tower
31 Market Street
Sydney, NSW 2000

PO Box Q128
Queen Victoria Building, NSW 1230

Phone: +61 2 8268 8689

Registered Manager (Exploration Manager): **Andrew Border**
(as per MSIA s33 or s41)

As above.

Radiation Safety Officer: Anthony O'Brien (current)

Radiation Safety Officer (Construction & Production: TBD
(as per MSIR r16.9 and RSR r18)

1.2 SCOPE OF PLAN

This Radiation Management Plan (RMP) is designed to satisfy the requirements of the Radiation Safety Act, 1975 (RSA) and Mines Safety and Inspection Act, 1994 (MSIA) for the identification, assessment, control and reporting of radiation hazards and risks on and associated with the Hasting Technology Metal Ltd ("the Company") Yangibana rare earth element mining and mineral processing operations ("the operation" or "the project").

Structure for this document is derived from the Western Australian Department of Mines and Petroleum *Managing naturally occurring radioactive material (NORM) in mining and mineral processing guideline, 2010*. This guideline is considered adopted as a requirement in the applicable jurisdiction(s) to the Yangibana rare earth element mining operations.

It is expected that this RMP overlaps with the greater occupational hygiene management plans and environmental managements plans. Wherever possible, procedures, work instructions, forms and training will be designed to emphasis the commonalities.

1.3 PROJECT OVERVIEW

The Yangibana Rare Earths Project is located in the upper Gascoyne Region of Western Australia, approximately 220km north-northeast of Gascoyne Junction and 450km north east of Carnarvon by road.

Rare earths oxides (REO) are found in the phosphate mineral monazite within ferrocarnatite veins. It is generally recognised that monazite contains low levels of radionuclides, predominantly thorium, with some uranium, and their respective decay progeny in approximate secular equilibrium. While levels of these parent radionuclides are low, they are present in sufficient concentrations to require that the project complies with legislation governing the mining and processing of naturally occurring radioactive material (NORM).

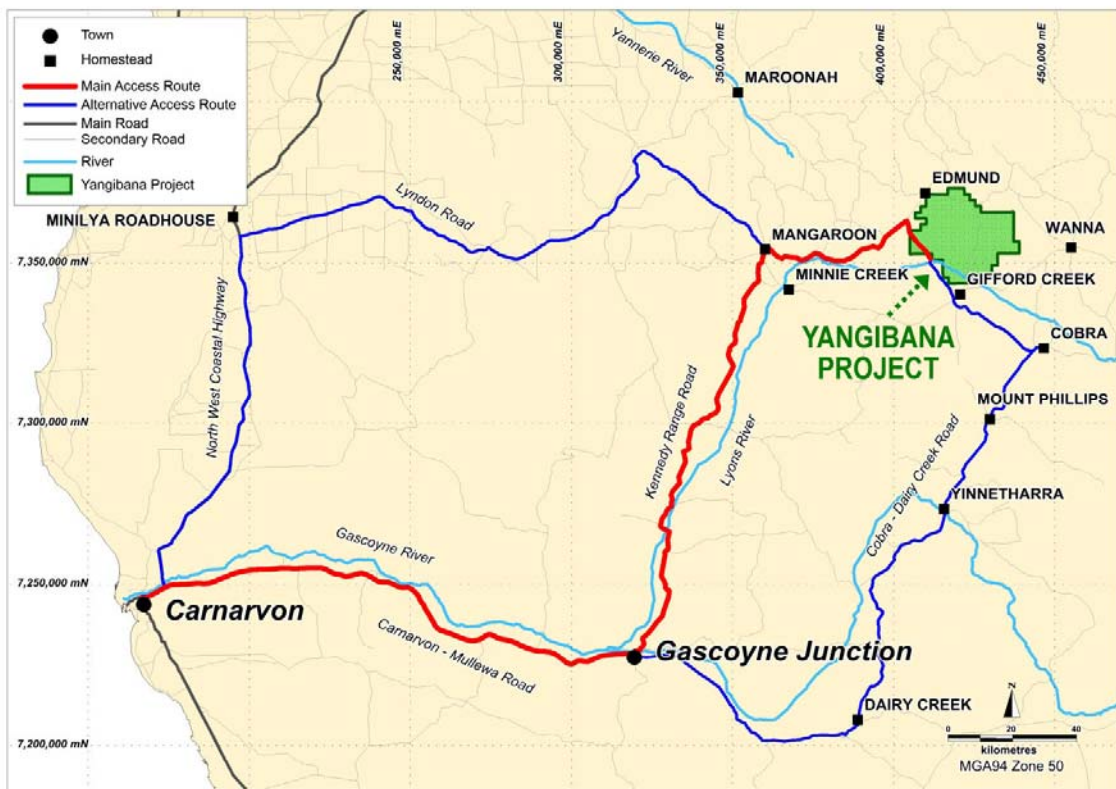

FIGURE 1 YANGIBANA PROJECT LOCATION

As such, to-date, activities of the project have involved mineral exploration under DMP *Programmes of Work* approvals and conform with a DMP Resources Safety Division approved Exploration Radiation Management Plan.

The project will be developed to include open cut pits and associated waste rock landforms, beneficiation and hydrometallurgical process plants, along with storage and disposal facilities for effluent and tailings streams from both plants. Additionally, the project will host an accommodation village, airstrip and ancillary infrastructure for power generation and water supply.

Production operations are expected to mine approximately 1 000 000 tpa of ore, with an average input concentration of around 0.9% rare earths oxides (REO). The processing plant is expected to produce approximately 12 880 tpa of rare earth product, which will be transported by truck to a port for export to overseas treatment facilities. Approximately 14 million tpa of waste rock will also be mined.

1.4 COMPLIANCE

A detailed plan to achieve compliance to the applicable radiation safety legislation is outlined in this document. A commitment matrix is provided in section 12 which links legislation with control, action and reporting requirements.

Over time, if changes are required to the RMP, this must be reflected in the commitment matrix. If a control or monitoring action is deemed unnecessary or any change is requested which reduces the risk management applied to a hazard, it must be justified via a detailed risk assessment, approved by the Principal Employer of the Company, and then approved by the relevant statutory authorities.

2 REGULATORY FRAMEWORK

2.1 YANGIBANA RARE EARTH ELEMENT PROJECT

The operation is situated in the upper Gascoyne region of Western Australia on the following tenements issued under the Mining Act, 1978.

TABLE 1 PROJECT MINING TENEMENTS

Lease	Grant Date	Holder(s)	Area (Ha)
G09/13	Pending	Gascoyne Metals Pty Ltd (70%), Mojito Resources Limited (30%)	277.20
G09/14	Pending	Gascoyne Metals Pty Ltd	286.08
G09/16	Pending	Yangibana Pty Ltd	389.83
L09/66	6-May-2016	Gascoyne Metals Pty Ltd	108.13
L09/67	8-Dec-2015	Gascoyne Metals Pty Ltd	6.79
L09/70	11-Dec-2015	Gascoyne Metals Pty Ltd	25.26
L09/71	11-Dec-2015	Gascoyne Metals Pty Ltd	5.65
L09/78	Pending	Gascoyne Metals Pty Ltd	82.00
L09/79	Pending	Gascoyne Metals Pty Ltd	34.01
L09/80	Pending	Gascoyne Metals Pty Ltd	232.87
M09/157	1-Jul-2015	Gascoyne Metals Pty Ltd	289.00
M09/159	1-Jul-2015	Gascoyne Metals Pty Ltd (70%), Mojito Resources Limited (30%)	1,469.83
M09/160	17-Nov-2015	Gascoyne Metals Pty Ltd	234.17
M09/161	25-Feb-2016	Gascoyne Metals Pty Ltd (70%), Mojito Resources Limited (30%)	313.10
M09/162	25-Feb-2016	Yangibana Pty Ltd	47.95
M09/167	Pending	Yangibana Pty Ltd	1,164.46

Correct as of 15 December 2016.

2.2 MINES SAFETY AND INSPECTION ACT, 1994

The *Mines Safety and Inspection Act, 1994* (MSIA) is the overriding safety legislation for all mining (including exploration and mineral processing) operations within Western Australia. This Act applies on all lands on which mining operations are being conducted even if exempt from the *Mining Act 1978*.

The MSIA replaces the *Occupational Safety and Health Act, 1984* for all operations defined as mining operations as per the MSIA and gives powers to appointed Inspectors of Mines to conduct inspections, investigations and issue improvement and prohibition notices on operations, equipment and actions as deemed necessary by the Inspector or State Mining Engineer (SME).

The MSIA determines the overarching responsibilities of the mine Principal Employer, Registered Manager and employees and the respective duties of care (MSIA s9).

2.3 MINES SAFETY AND INSPECTION REGULATIONS, 1995 PART 16

While the entire *Mines Safety and Inspection Regulations* (MSIR) is applicable to the project, this RMP has been designed to specifically address Part 16 which deals with ionising radiation hazards. MSIR pt16 includes, but is not limited to:

- Definition of mining operations subject to MSIR pt16
- Duties and responsibilities of the Registered Manager under MSIR pt16
- Duties and responsibilities of the Radiation Safety Officer (RSO) under MSIR Pt16
- Radiation exposure standards
- Requirements to have a RMP in place and its function
- Reporting requirements to the DMP
- Requirements for sealed sources and fixed gauges

Enabled via State Mining Engineer recommendation is the Western Australian DMP *Managing naturally occurring radioactive material (NORM) in mining and mineral processing* (“the Guidelines”) which are under review at the time of this document.

2.4 RADIATION SAFETY ACT, 1975

The *Western Australian Radiation Safety Act, 1975* (RSA) is the overarching legislation for radiation safety in Western Australia. It legislates the requirements for a governing council, called Radiological Council, to advise the Minister for Health. Functions of the RSA are administered by the Radiation Health Branch of the Western Australian Department of Health.

Functions of the RSA, with reference to the operation include, but are not limited to:

- Registration of a radiation place
- Licensing of competent people to handle or otherwise work with radioactive sources, materials and devices
- Appointment of Radiation Safety Officers (RSO)
- Transport of radioactive material (Class-7 dangerous goods¹) on public roads
- Ensure the principles of radiation protection (ALARA²) are implemented with regard to any exposure to workers, members of the public or the environment

¹ The Western Australian Dangerous Goods Act does NOT apply to Class-7 radioactive material. Any license, approval or permission issued under this legislation does not apply to class-7 dangerous goods.

² Radiation protection does NOT use ALARP as per other legislation. Radiation exposures are to be *As Low As Reasonably Achievable*.

2.5 MOU BETWEEN RADIOLOGICAL COUNCIL & DEPT OF MINES AND PETROLEUM

Where the RSA and MSIA overlap, a Radiation Liaison Committee (RLC) has been established to convene representatives from Radiological Council and DMP to discuss matters where both statutory authority has some jurisdiction.

Matters such as approval to appoint a RSO, or approve a RMP are discussed in this committee however it should be noted that any contentious issue, practice or operation is also discussed. Any application from a mining operation that requires dual approval will need to be discussed and jointly approved via this mechanism.

It should be noted that an approval or permission issued by either party to the MOU does not imply the other party has issued a counter-approval or permission. Approvals and permissions must be issued by both parties to be valid.

2.6 ARPANSA

The *Australian Radiation Protection and Nuclear Safety Agency* (“ARPANSA”) provides codes and guidance intended for use nationally by the various statutory authorities around Australia. It should be noted that ARPANSA has no jurisdiction of any geographic location or area within Australia, only over Commonwealth organisations such as CSIRO, DSTO, Australian Customs etc.

ARPANSA documents that will be used or referenced in this RMP include (but are not limited to):

- Code of Practice for the Safe Transport of Radioactive Material RPS2, 2014 (“Transport code”)
- National Directory for Radiation Protection RPS 6, 2014 (“National directory”)
- Code of Practice and Safety Guide for Radiation Protection and Radioactive Waste Management in Mining and Mineral Processing RPS9, 2005 (“Mining code”)

2.7 PURPOSE OF THE RADIATION MANGEMENT PLAN

The purpose of the RMP is to demonstrate to the relevant statutory authorities that the Principal Employers, in conjunction with the Registered Managers have accessed the risks associated with their operation, established standards around acceptably exposures to workers, members of the public and the environment and developed control and monitoring strategies to mitigate those risks as a complete safety management system (SMS).

Reporting requirements following the RMP are to demonstrate the system has been implemented, resources and continues to be reviewed and improved.

3 YANGIBANA OPERATION DESCRIPTION

3.1 ENVIRONMENT

For more information regarding environmental conditions at the Yangibana project, please refer to Appendix 2.

3.2 GEOLOGY

For more information regarding geological conditions at the Yangibana project, please refer to Appendix 5.

3.3 WORKFORCE

The workforce is expected to contain a mix of day admin, day work (day shift only) and shift work (combination of day and night shift) totalling approximately 250-270 people.

More information on workforce and similar exposure groups can be found in section 5.4.

3.4 CONTINUED EXPLORATION ACTIVITIES

Hasting has a RMP currently approved for exploration activities at the Yangibana project. This RMP will supersede that approved document with low risk exploration activities captured as a *similar exposure group* (SEG) within the Yangibana project work force.

Exploration activities handle material only at ore grade concentrations of Uranium and Thorium and only in relatively limited quantity. Radiological hazard controls during exploration will be identical to those for surface mining of the ore body (see section 3.7).

3.5 CONSTRUCTION ACTIVITIES

During construction activities, land clearing and shallow earthworks, it is expected that low uranium and thorium bearing material not in the vicinity of the main ore bodies will be disturbed. Potential exposure to personnel during this phase is expected to be negligible however positional dust monitoring, personal gamma exposure and hygiene controls will be in place to instigate the safety systems required during commissioning and production.

No additional control strategies are expected to manage the potential radiological risk to workers (employees) and high number of contractors expected during this period.

Focus during this phase will be on creating a safety culture and ensure all monitoring and training systems are well developed and implemented in preparation for operations.

3.6 COMMISSIONING ACTIVITIES

Commissioning of the beneficiation and hydrometallurgy plant may create a concentrated product and tails stream with higher than natural levels of uranium and thorium found in the main ore bodies. During this phase the potential radiological exposure risks are higher than in previous phases due to engineering controls not being fully implemented or potentially bypassed while the plant is being tested and commissioned.

As both the beneficiation and metallurgy plants are wet process plants, the potential for airborne dust exposure is highest following material spills or process upsets that leave material outside of the process to dry and potentially become airborne.

Additional control strategies to prevent the accumulation of concentrate and also manage the potential risks associated with the high number of contractors during commissioning are expected during this phase.

It is expected that there will be additional monitoring and audits to the monitoring program however no new control types to those already identified in this RMP.

3.7 MINING & HAULING OPERATION

Due to the low uranium and thorium content in mined ore, potential radiological hazards are not expected to be significant during mining however controls such as filtered air into mining vehicles to prevent dust inhalation, restricting access to stockpiles and ROM pad and personal gamma dosimetry will be conducted commensurate with the risks associated with mining.

Figure 3 shows the ore grade uranium and thorium concentration in mined ore and its comparison to concentrate and product levels.

3.8 BENEFICIATION & HYDROMETALLURGY

An overview of beneficiation and hydrometallurgical processing operations is available in Figure 2 and shows the flow of ore, concentrate and waste products throughout the system.

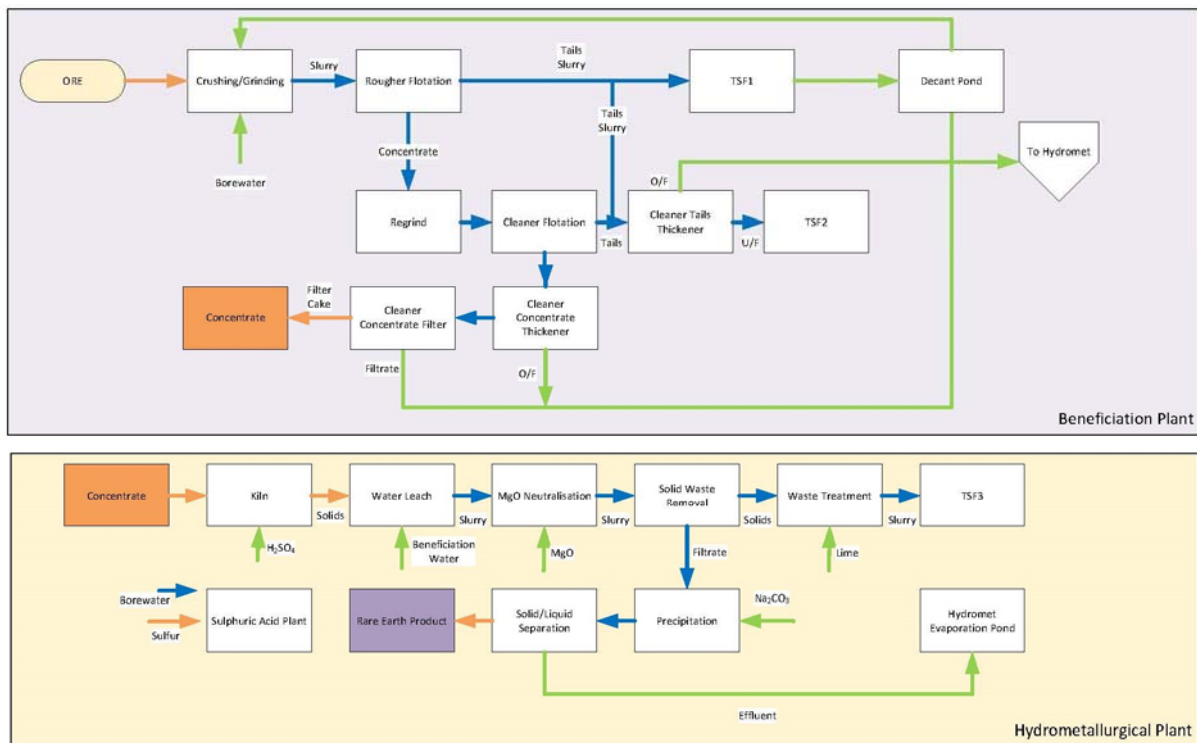

FIGURE 2 BENEFICIATION & HYDROMETALLURGICAL PLANTS

It can be seen in Figure 3 that thorium levels are enhanced via the beneficiation and hydrometallurgy plant in concentrate, TSF2 and TSF3 streams to levels significantly higher than found in the ore. This increases the potential risk associated with dust inhalation and gamma exposure to personnel working in the area.

The focus of occupational exposure will be focused around this area to ensure engineering controls are effective and administrative controls are implemented and managed.

More information regarding the radionuclide characterisation can be found in the Radiation Waste Characterisation report (Radiation Professionals, 2016).

3.9 TAILING STORAGE

A number of tailing storage facilities (TSF) will be utilised during production for the three (3) main waste streams from the beneficiation and hydrometallurgy plants. Figure 2 shows where the planned process waste streams are generated.

Figure 3 (pg 17) shows modelled concentrations and produced quantities of uranium and thorium in the feedstocks, production materials and waste streams.

A more detailed study of the TSF design, operation and justification can be found in the Hastings Radioactive Waste Management Report (Hasting, 2016).

3.9.1 TSF 1

TSF1 is a mostly benign waste stream from water flotation separation of ore. Uranium and thorium concentrations levels after first stage beneficiation are expected to be lower than the original ore grade and constitute the bulk (by quantity) of waste produced.

TSF1 waste will be monitored however it is not expected to be a potential radiological hazard.

3.9.2 TSF 2

Modelled radionuclide concentrations in TSF2 waste are expected to be higher than ore feedstock and as such potentially pose a radiological hazard. Based on modelling the total production quantity of waste from TSF2 is expected to be limited compared to feedstock ore inputs, approximately 37,000 tonnes (20% w/w solids) per 1,000,000 tonnes feedstock ore.

TSF 2 waste will be monitored as it is expected to be a potential radiological hazard to workers or the environment if not properly managed.

3.9.3 TSF 3

Modelled radionuclide concentrations in TSF3 waste are expected to be higher than ore feedstock and as such potentially pose a radiological hazard. Based on modelling the total production quantity of waste from TSF3 is expected to be limited compared to feedstock ore inputs, approximately 56,000 tonnes (30% w/w solids) per 1,000,000 tonnes feedstock ore.

TSF3 waste will be monitored as it is expected to be a potential radiological hazard to workers or the environment if not properly managed.

3.10 PRODUCT STORAGE

Modelling indicated that thorium reports strongly to intermediary concentrate but not the final product from the mineral processing plant. Final product is expected to contain significantly lower thorium concentrations than the feedstock ore.

In contrast, uranium concentrations which build up throughout the mineral processing system will be higher than feedstock ore.

Until proven otherwise a precautionary approach is used in this RMP and final product will be treated as a potential radiological hazard to workers, the environment or members of the public if not properly managed.

Final rare earth product modelling is yet to determine if it is a prescribed material.

3.11 PRODUCT TRANSPORT

A precautionary approach to radiation safety during transport will be taken until further modelling or testing or final product proves otherwise.

In this preliminary RMP, final product will be classed as prescribed radioactive material as per the Radiation Safety Act and Transport code and shipped as Dangerous Goods Class-7 UN2912.

Proper shipping name: **UN2912 Class-7 Radioactive Material Low Specific Activity (LSA-I non-fissile or fissile excepted)**

As product is transported on public roads it may become stationary for more than 24 hours while in transit. RS(G)R r28A(1)(b) specifies that the storage facility is exempt from registration if “each package containing a radioactive substance is stored on the premises for 24 hours or less”.

It is likely that a registered premise will be required at the export port used for product sale.

Final product testing will determine if the following exemption can be applied during transport:

Transport code 107(f)

Natural material and ores containing naturally occurring radionuclides, which may have been processed, provided the activity concentration of the material does not exceed 10 times the values specified in Table 2, or calculated in accordance with paras 403(a) and 404–407. For natural materials and ores containing naturally occurring radionuclides that are not in secular equilibrium the calculation of the activity concentration shall be performed in accordance with para. 405.

4 SOURCES AND PATHWAYS OF RADIATION EXPOSURE

4.1 RADIATION BASICS

It is not the purpose of this document to provide introductory level information to new workers with regard to how radiation effects people and the environment. For further information, please refer to the following:

- *Radiation Workers' Handbook: Radiation Control in the Mining Industry* released by the Minerals Council of Australia and
- *Fundamentals for Protection Against Ionising Radiation* release by ARPANSA

Of particular note, should be the following disclaimer found in the opening pages of the handbook:

This booklet has been written about the hazard of radiation and its controls. Other hazards have not been discussed in detail. Safety manuals are available at mines and mills which deal specifically with other hazards. Radiation has been given a booklet of its own, not because it is the greater hazard, but because it is invisible and not widely understood.

4.2 RADIATION IMPACT ASSESSMENT

Following a radiation impact assessment (JRHC, 2016) the main pathways for exposure to personnel was identified to be:

- Gamma exposure from material in mining area, concentrate and TSF3 stream waste
- Dust inhalation from airborne (dry) material from concentrate and TSF3 stream waste

The impact of radon, thoron and their respective progeny is not expected to constitute a major contributing factor to workers and member of the public occupational exposure during the life of this project. Levels will be monitored however the focus of hazard controls will be regarding gamma exposure and dust control techniques.

Total dose to workers in mining, beneficiation and hydrometallurgy was assessed based on assumptions where possible, and reference data from comparable operations (BHP, Olympic Dam 2001-2007) and are listed below.

TABLE 2 MINING OPERATIONS RADIATION DOSE ASSESSMENT (JRHC, 2016)

Work Group	Dose (mSv/y)					Total
	Gamma	RnDP	TnDP	Dust (U)	Dust (Th)	
Miners	0.9	0.01	0.03	0.08	0.12	1.3 <i>0.325 mSv/qtr</i>

It can be seen than expected dose to personnel is expected to be safety below the external gamma dose (2.5mSv/qtr) and internal dust, Rn & Th dose (0.25mSv/qtr)

investigation limits (see Table 2 and Table 3 for assessments and Appendix 2 for investigation limits).

TABLE 3 BENEFICIATION AND HYDROMETALLURGY RADIATION DOSE ASSESSMENT (JRHC, 2016)

Processing Plant Work Area	Doses (mSv/y)			
	Gamma	Dust (U&Th)	RnDP	Total
Beneficiation Plant	0.3	0.3	0.1	0.7 <i>0.175 mSv/qtr</i>
Hydrometallurgical Plant	0.8	0.7	0.3	1.8 <i>0.45 mSv/qtr</i>

For more a more detailed report regarding radiation impacts to workers, please refer to the Radiation Impact Assessment, 2016 conducted by JRHC Enterprises Pty Ltd.

As the Yangibana project completes construction and commissioning and actual data becomes available for radiation exposures to workers, the assumptions of the radiation impact assessment will be reviewed and where necessary revised.

4.3 MATERIAL CHARACTERISATION

Material characterisation clearly shows the increasing level of thorium throughout the mining and mineral processing phases resulting with a high thorium content tail from the hydrometallurgy process and a slightly elevated uranium content in the final product.

		Material	Uranium		Thorium		U+Th
		tpa	Bq/g	ppm	Bq/g	ppm	Bq/g
INPUT	Beneficiation						
	Ore	1,000,000	0.37	29.97	2.10	516.60	2.47
OUTPUT	TSF1	932,133	0.25	20.25	0.38	93.48	0.63
	TSF2	37,200	0.59	47.79	6.20	1525.20	6.79
	Concentrate	30,667	0.92	73.8	37.7	9274.2	38.62
	Waste Rock	14,000,000	0.31	73.8	0.13	10.4	0.44
INPUT	Hydrometallurgical						
	Concentrate	30,667	2.20	178.20	37.10	9126.60	39.30
OUTPUT	TSF3	56,000	1.45	117.45	22.70	5584.20	24.15
	Product	12,880	3.3	267	0.02	6	3.32

FIGURE 3 MATERIAL CHARACTERISATION (RADIATION PROFESSIONALS, 2016)

While it is expected that radiation exposure to workers via the known radiation pathways will occur, these exposures will be below regulatory limits and pose no immediate or longer term risk compared with other day-to-day activities.

For more information regarding comparison of risk, please refer to the radiation worker’s handbook.

TABLE 4 RADIATION RISK IN PERSPECTIVE

Risk in perspective	
Category	Average Life Lost (days)
Smoking 20 cigarettes per day	1600
Being 15% overweight	900
Agricultural worker	320
Consuming alcohol (US Avg.)	230
Construction worker	227
Driving a car	200
Mining and quarrying workers	167
Manufacturing worker	40
Recreational swimming	40
Radon exposure	35
Skydiving	25
Radiation worker age 18 - 65 (3 mSv per yr)	15
All natural hazards	7
Riding a bicycle	6

It should be noted that non-compliance with statutory exposure limits does not necessarily imply an exposure risk. For more information in investigation limits see section 7.4. All statutory limits and investigation limits are considered highly conservative. Therefore, a non-compliance is unlikely to result in more than negligible health effects on workers or the environment.

This approach is in keeping with the risk-based approach to risk management.

4.4 WORKFORCE

The production workforce is expected to employ approximately 200-260 personnel in various FIFO shift rosters as out lined below.

TABLE 5 WORK SHIFTS

Shift	Hours/day	Config on/off
Day admin	12	8:6
Day work	12	14:7
Shift work	12	14:7

As radiation risk exposure varies between the work roles in the project, similar exposure groups (SEG) will be defined within the workforce for roles with similar risks. Each SEG will have a monitoring program commensurate with the types of radiation exposure that may occur.

More information on SEGs can be found in section 5.4.

4.5 CRITICAL GROUPS

Three critical groups exist for the project:

- Accommodation Village (approximately 5km from the main project area)
- Giffords Creek (approximately 30km to the south of the main project area)
- Edmund Station (approximately 30km north of the main project area)

The Accommodation village will be treated as a member of the public space occupied by workers. As no radioactive material is expected to be in the area gamma emissions can be assumed to be background and no active gamma monitoring will take place. Positional monitoring to attribute a dose (dust & radon/thoron) dose to workers on a per hour basis will be conducted to assess radiation doses to workers during stays in the Accommodation village on an annual basis.

Members of the public at Giffords Creek and Edmund Station are expected to only be potentially exposed to dust and radon/thoron gas given their distance from the operation. As with the village positional monitoring will be conducted on a regular basis to assess radiation doses to members of the public over a year.

The Radiation Impact Assessment (JRHC, 2016) supports that the radiological impact to members of the public will be below 1mSv/yr.

5 RADIATION EXPOSURE CONTROLS & METHODOLOGIES

5.1 RADIATION PROTECTION STANDARDS

Due to the specific activity of U and Th in concentrate and tailings the total average personal annual dose could potentially exceed 1 mSv should controls fail, therefore the Mines Safety and Inspection Regulations 1995 - Part 16 Radiation Safety applies.

5.1.1 EXPOSURE STANDARDS

The annual occupational and member of the public radiation dose limits for the operation are 20 mSv and 1 mSv respectively.

5.1.2 CONTAMINATION STANDARDS

In accordance with international and Western Australian transport safety regulations, the surface contamination limit of 0.4 Bq/cm² is adopted for skin and protective clothing of all personnel and for tools and equipment leaving the site.

5.1.3 COMPETENT PERSONNEL

A suitably qualified Radiation Safety Officer is appointed and is responsible for the implementation of the RMP and the radiation protection monitoring program.

5.1.4 COMPLIANCE WITH SAMPLING STANDARDS

A fully qualified Surface Ventilation Officer is appointed to ensure that all air sampling and monitoring is undertaken in accordance with the Australian Standards and West Australian guidelines.

5.2 TRAINING & INDUCTION

Records of all inductions are to be kept and accessible to the Radiation Safety Officer at all times.

Training and awareness material will not be reworded versions of existing material. Instead already published industry handbooks will be utilised to ensure a consistent and validated message is communicated to the workforce.

The Mineral Council of Australia *Radiation Workers Handbook* will be used during inductions and made available to all workers on-site.

http://www.minerals.org.au/file_upload/files/publications/3.1D_Download_Radiation_Workers_Handbook_1862009.pdf

5.2.1 ALL WORKERS TO SITE

All workers (including visitors) entering site must undergo a basic radiation safety induction. This induction will outline the controlled areas of the project, hazard and

warning signs appropriate to those areas and the requirements of all workers and people on site with respect to monitoring, hygiene and PPE.

Should there be any major change in the operation that requires a revised RMP to be developed, this change is to be reflected in the basic radiation safety induction. A typical change that would trigger reinduction is change in controlled areas defined on-site.

5.2.2 CONTROLLED AND RESTRICTED AREAS

All worker entering controlled and restricted areas must undergo a detailed radiation safety induction, designed and approved by the RSO with assessment that the worker understands the additional controls and requirements.

Controlled and restricted area inductions are to be repeated every 2 years.

5.2.3 RADIATION SAFETY OFFICER AND DEPUTIES

Radiation Safety Officers appointments are to be approved by the State Mining Engineer (MSIR r16.9 and Secretary of Radiological council (RS(G)R r18) before any appointment takes effect. The RSO is to meet the training and experience criteria for the role and the risk profile of the specific operation.

Radiation Safety Officer Deputy(s) is appointed by the RSO and/or Registered Manager to fulfil the duties of the RSO while not on-site. Should the Appointed RSO be away from site for a length of time longer than 4 consecutive weeks, the State Mining Engineer and Secretary of Radiological Council are to be notified.

5.3 CLASSIFICATION OF WORKPLACES

Certain workplaces near the processing plant and TSFs will potentially pose more radiological hazards to workers than other workplaces such as the admin buildings and workshops. As such certain workplaces (or shutdown activities) shall be classified as either supervised, controlled or restricted.

The MSIR outlines the following requirements on a project with regard to supervised and controlled areas.

MSIR r16.12. Supervised areas and controlled areas

(1) Each responsible person at a mine must ensure that in any area designated in a radiation management plan as a controlled area –

(a) access is limited to those persons who are required to work, or perform any duty under this Act, in the area;

(b) the boundaries of the area are clearly delineated and are made known to employees at the mine; and

(c) any person entering the area has received appropriate instructions about the nature of the radiation hazards in the area.

- (2) Each responsible person at a mine must ensure that in any area designated in a radiation management plan as a supervised area –*
- (a) access by members of the public is supervised; and*
 - (b) the boundaries of the area are clearly delineated and are made known to employees at the mine.*

In addition, the following investigation limits have been established around supervised, controlled and restricted areas in Appendix 2.

TABLE 6 WORK AREA CLASSIFICATIONS

Classification	Investigation limit
Supervised area	More than 0.50 µGy/hr above background
Controlled Area	More than 2.50 µGy/hr above background
Restricted	More than 7.50 µGy/hr above background

(Ref Appendix 2)

5.3.1 SUPERVISED AREAS

The entire operational area of the mining operation and processing plant site are defined as supervised areas. Access to the public is limited and no worker is permitted within the supervised areas without a basic radiation safety induction.

Wearing of a TLD/OSL (at RSO discretion) and participation in airborne dust monitoring is mandatory for workers in the supervised area.

5.3.2 CONTROLLED AREAS

Controlled areas of the project include the mining pit, processing plant and TSFs. Access to these areas is restricted to only those workers who have had a detailed radiation safety induction and are competent in the radiation safety controls used in this area.

In addition to the requirements of a supervised area, workers in a controlled area are also required to wear appropriate PPE and observe personal hygiene and contamination control procedures.

5.3.3 RESTRICTED AREAS

Restricted areas of the project include any work during production or shutdowns than may exposure workers to higher than normal radiation dose rates. Any actions within a restricted area cannot be conducted without notification and approval of the RSO (or deputy).

In addition to the requirements of a supervised area and controlled area, workers within a restricted area must also ensure a risk assessment and radiation permit to work has been approved to conduct the work in this area.

5.4 SIMILAR EXPOSURE GROUPS (SEGS)

All workers shall fall into one of the following similar exposure groups (SEGS).

	Similar Exposure Group	Shift hours/day	Config on/off
Mining operations	Shift work	12	14:7
Processing technical	All	12	14:7
Processing production	All	12	14:7
Maintenance & engineering	All	12	14:7
Laboratory – sample prep	Shift work	12	14:7
Laboratory – other	All	12	14:7
TSF operators (inspection)	All	12	14:7
Transport	--	--	
Admin/projects /support	Day admin	12	8:6

Dose assessments shall be determined as per DMP guideline NORM-5 quarterly, and reported annually as per MSIR r16.26.

5.5 WORK PERMITS

When work is to be conducted that is not *normal project process operations* in areas with higher concentrations of thorium bearing material, a radiation permit to work will be required. The permit will provide evidence that a JSEA has been completed by the work crew and it has been approved by the Radiation Safety Officer as adequate for the work to be undertaken.

Examples of tasks that may require a radiation work permit includes, but is not limited to:

- Shut down and maintenance of the beneficiation and/or hydrometallurgy plant
- Any work that bypasses engineering control systems
- Any work inside or near large slurry tanks or stockpiles
- Any work related to fixed density gauges

5.6 DUST SUPPRESSION

All stockpiles and surfaces that may be subject to wind-blown material being spread shall have adequate dust suppression controls. Dust suppression controls may include, but are not limited to:

- Water tanks on haul roads with mineral ore on surface
- Sprinkler systems on stockpiles used for blending material on ROM pad prior to feeding into beneficiation plant
- Water curtains, covers and similar containment controls for conveyors and bulk material transport systems
- Sealant such as Gluon or molasses for stockpiles that are to remain in place for extended periods of time
- Capping of TSF surfaces where appropriate prior to permanent closure

As final design of mining and processing plants is not yet finalised, specific sources of dust creation are not yet identified. As the project moves from construction to commissioning to production a detailed initial monitoring campaign shall be undertaken. This shall establish the dust producing areas of the plant. After incorporating the Uranium & thorium content of those dust sources, the highest airborne radioactive dust hazards onsite will be determined.

5.7 HOUSEKEEPING

Housekeeping rules include maintaining a relatively clean and dust free work place to ensure workers in the crushing, milling, beneficiation or hydrometallurgy plants do not disturb aggregated dust on the floor or on top of equipment, potentially creating a high dust area and therefore a high inhaled radiation dose.

In addition, all filters and systems that remove or control dust in occupied work areas shall be periodically cleaned. Worker responsible for cleaning and/or handling the filters may potentially be in close proximity to fine dust with high radiation concentrations and as such should be handled with extra controls.

5.8 PERSONAL HYGIENE

To control the transfer of radioactive materials from controlled areas to non-controlled areas, and also from hands and skin of workers to be ingested via food and drink, strict but tiered personal hygiene requirements will be in place in different work areas.

As the project moves from construction to commissioning to production a detailed initial surface and worker's clothing contamination campaign shall be undertaken. This shall establish the types of controls best suited to controlling the spread of radioactive material onsite that will provide the best protection from ingested radioactive material.

Requirement in supervised areas will include, but not be limited to:

- Washing hands and face before entering break rooms
- Bootwashing/brushing stations and the entrance to all buildings to reduce low level radioactive material brought into buildings via foot traffic.

Requirements in controlled area will include, but not be limited to:

- Change rooms for personnel working in controlled areas to remove contaminated clothes before entering supervised areas or leaving site.
- Wash stations at all break rooms and control rooms/buildings inside the controlled areas for washing of hands and faces and prevent the transfer of radioactive material into occupied areas.
- Disposable PPE where appropriate (ear plugs, dust masks, dust suits etc) to prevent the transfer of radioactive material outside controlled areas.

5.9 SURFACE CONTAMINATION CONTROL

Control of surface contamination and the subsequent spread of radioactive material throughout and off the project is critical for ensuring radiation protection.

Contamination is defined as 0.4 Bq/cm² averaged over 300cm² (ARPANSA, RPS2) however handheld surface contamination devices do not measure (reliably) in these units. All equipment used for surface contamination inspection tests MUST have a surface contamination response calculation to convert the statutory limit to a response on the meter.

Typically, this is done using the meter response efficiency (dps/cps %) over either a 2π or 4π geometry. An example of this calculation is given in the *Vehicle/equipment Clearance Procedure*. This calculation is expected to be within the expected competencies for the appointed RSO.

Surface contamination inspections shall be conducted for the following:

- All mobile plant leaving the controlled area that has come in contact with concentrate of tails stream waste
- All mobile plant involved in any work in a restricted area
- All plant or equipment leaving the mining or processing areas
- Periodic inspection of personnel leaving the controlled area
- Periodic inspection of work areas such as control rooms and break areas inside the controlled area
- Periodic inspection of the personnel cleaning and washing areas inside the controlled and supervised area
- Periodic inspection of all vehicles on-site

5.10 SIGNAGE

To ensure proper awareness of radiation safety procedures when entering supervised, controlled and restricted areas, the following signage will be used to notify or warn of hazards as appropriate.

5.10.1 SUPERVISED AREA SIGNAGE

Upon entering the mining and processing operations area, the security gate shall have the following notification sign for all workers and visitors to site (Figure 4).



FIGURE 4 SUPERVISED RADIATION AREA NOTICE SIGN

5.10.2 CONTROLLED AREA SIGNAGE

The boundary to all controlled areas shall be clearly demarcated with permanent barricades or utilise existing walls, fences with all entry points signed with the following caution/hazard sign (Figure 5).



FIGURE 5 CONTROLLED RADIATION AREA HAZARD SIGN

5.10.3 RESTRICTED AREA SIGNAGE



FIGURE 6 RESTRICTED RADIATION AREA HAZARD SIGN

6 RADIATION MONITORING PROGRAM

The following outlines a typical radiation monitoring program for a project as proposed for the Yangibana rare earth element project. As the project is still only proposed, the monitoring outlined below is subject to review and refinement as monitoring data during production becomes available.

6.1 OCCUPATIONAL RADIATION EXPOSURE PROGRAM

6.1.1 EXTERNAL EXPOSURE TO GAMMA RADIATION

- Surveys of the mining pit or its boundary - at least four times per year
- Surveys of the product storage area or its boundary - at least four times per year
- Surveys of the waste dump or its boundary - at least four times per year
- Surveys of the concentrator plant and surroundings - at least four times per year;
- Surveys of the boundary of the tailings storage facilities (TSF) - at least four times per year;
- Concentrate temporary storage areas - At least four times per year; and
- Every full-time employee who is expected to spend a significant proportion of their working time in radiation supervised areas will wear a TLD/OSL badge.

6.1.2 DUST MONITORING

- 10 personal dust samples per month in processing areas,
- 10 personal dust samples per month in mining/ crushing areas
- 10 personal dust samples per month for maintenance personnel
- Positional (area) samples will be taken at the discretion of site's ventilation officer.

6.1.3 INTERNAL RADIATION EXPOSURE - RADON AND THORON

- Further investigative monitoring of internal exposure to radon and thoron gas will be carried out when mining campaigns occurs

6.1.4 SURFACE CONTAMINATION MONITORING

- Measurements per quarter from mobile equipment, light vehicles and from offices, crib room and the plant;
- All mining and crushing equipment to be checked before leaving site.

6.2 ENVIRONMENTAL RADIATION EXPOSURE PROGRAM

Environmental monitoring program is determined by the Radiation Waste Management Plan and takes precedence to this document.

6.2.1 ENVIRONMENTAL GAMMA-RADIATION SURVEYS

- Surveys of the boundary of the mining pit - four times per year,
- Surveys of the site boundary - four times per year,
- Surveys of the product transport route - once per year

6.2.2 DUST MONITORING

- Four high volume samples collected from each identified location every quarter, representing a total of 16 samples,
- Additional sampling may be carried out at the discretion of the SVO or RSO.

6.2.3 GROUND WATER MONITORING

- Water sampling from monitoring bores for concentration of Ra226 and Ra228.

6.3 RADIATION MONITORING RESOURCES

The following equipment is proposed to be used to monitor radiation as per this RMP. All suggestions are subject to availability however it is not recommended that inspection equipment is swapped for alternate models or types without approval of the Radiation Safety Officer.

- Gamma-radiation and surface contamination: RadAlert 'Inspector', preferably with GPS logging ability.
- Gamma-radiation: a set of personal electronic dosimeters
- Gamma personal dose: ARPANSA TLD/OSL badge for all personnel working in controlled or restricted areas.
- Personal dust monitoring: two sets of personal dust samplers with the calibrator and appropriate cassettes;
- Hi-Vol dust monitoring: appropriate high volume sampler (Ecotech) is hired when the sampling needs to be undertaken
- Dust monitoring: Canberra 7401 alpha-spectrometer with calibration sources.

7 RECORD KEEPING & REPORTING STANDARDS

All Occupational Radiation Exposure Annual Reports and Environmental Radiation Annual Reports are to be in a format as approved by the State Mining Engineer, such that it conforms with the recommendations in the DMP Guideline NORM-6 *Reporting Requirements*.

7.1 RECORDS

The project will keep true and accurate records of all radiation safety related information including, but not limited to:

- Records of radiation protection training of workers and contractors
- Records of radiation protection monitoring and survey results
- Records of inspections and internal and external audits
- Records of any special and/or accidental exposures
- Records of the environmental radiation monitoring
- Records of tailings deposited into the TSF, including tonnages and thorium and uranium concentrations
- Any other relevant information that may be required to be recorded in accordance with this plan, or as instructed by the State Mining Engineer.

7.2 OCCUPATIONAL RADIATION EXPOSURE ANNUAL REPORT

An Occupational Radiation Exposure Annual Report, summarising the results of occupational exposure radiation monitoring shall be submitted to the State Mining Engineer for the April-March period, in May each year.

For more information on the occupational exposure radiation monitoring program, please refer to section 6.1.

7.3 ENVIRONMENTAL RADIATION ANNUAL REPORT

An Environmental Radiation Annual Report, summarising the results of environmental radiation monitoring shall be submitted to the State Mining Engineer for the October-September period, in November each year.

For more information on the environmental radiation monitoring program, please refer to section 6.2.

7.4 INVESTIGATION AND ACTION THRESHOLDS

The investigation levels in Appendix 2 are derived directly from the NORM Guideline recommendations.

All monitoring and/or reporting will be compared against these investigation limits and appropriate CAPA (Corrective action – preventative actions) will be taken.

8 TRANSPORT OF PRODUCT

A Radioactive Transport Management Plan (preliminary until further information on the final product becomes available) has been designed which addresses transport requirements in more detail than outlined in this RMP.

Below is an overview of transportation radiological risks as pertinent to the RMP, legislative compliance and radiation safety commitments.

As most transported mineral products are required to be dry for both on site handling and consumer demand, suitable dust control measures are used to minimise exposure to workers and environmental contamination. Control measures include:

- Silo or bin chute flow controls located a reasonable distance from the chute
- Use of telescopic chutes at the base of product loading bins to minimize dust by decreasing the drop distance of product
- Telescopic chutes to reduce dust from loading of dry mineral product
- Loading sites are open-aired and therefore well ventilated
- Distance between the load in the trailer and the driver in the cab: for a normal semi-trailer the distance is approximately five metres and for a belly-dumper, seven metres. This distance greatly reduces any gamma radiation to the driver.

8.1 GENERAL RADIATION EXPOSURE SCENARIO

The thorium and uranium head of chain concentrations in the final product are modelled to be 6 ppm of Th-232 and 267 ppm of U-238, which will have a specific activity in the order of 3.3 Bq/g.

The levels of gamma-radiation emitted from the final product is expected to be above the natural background levels however the contribution of this from progeny radionuclides such as Ra-226, Ra-228 and Th-228 is unknown at this time. As such radiation exposure levels for workers involved in final product handling and transport will require conservative controls and management.

It will be necessary to verify the levels of radiation exposure of workers that will be involved in transport of the final product once production begins. Until such time as radionuclide analysis that includes progeny isotopes for the final product is available, the conservative approach to radiation safety during product handling and transport will be maintained.

8.2 U (NAT) & TH (NAT) EXEMPTION

RPS2 (ARPANSA, 2011) Section IV, Table 1 gives the *Activity concentration limit for exempt material* values for Th (nat) and U (nat) at 1.0 Bq/g each. Paragraph 107 provides exclusion for the final product.

107. The Regulations do not apply to:

(e) natural material and ores containing naturally occurring radionuclides that are either in their natural state, or have been processed only for purposes other than for the extraction of the radionuclides, and that are not intended to be processed for use of these

radionuclides, provided that the activity concentration of the material does not exceed 10 times the values specified in para. 401 (b), or calculated in accordance with paras 402-406

As the final product will be subjected to chemical processing, it is highly likely that radionuclides in both thorium and uranium decay chains are considered to be out of equilibrium and therefore the RPS2 r107(e) exemption for natural uranium and thorium ores does not apply.

It is, therefore, concluded that there is requirement for placarding of the containers as 'radioactive', likely UN2912.

9 RADIOACTIVE WASTE MANAGEMENT PLAN (TAILS STORAGE)

A detailed Radioactive Waste Management Plan has been conducted (Hastings, 2016) which outlines in detail the TSF design, operation and justification.

10 REFERENCES

- Mines Safety and Inspection Act, 1994
- Mines Safety and Inspection Regulations, 1995
- Radiation Safety Act, 1975
- Radiation Safety (General) Regulations, 1983
- Radiation Safety (Transport of Radioactive Substances) Regulations, 2002
- Code of Practice for the Safe Transport of Radioactive Material RPS2, ARPASNSA 2011
- Western Australian Department of Mines and Petroleum NORM guideline, 2010
- AS2985 – Workplace atmospheres – Method for sampling and gravimetric determination of respirable dust
- AS3640 – Workplace atmospheres – Method for sampling and gravimetric determination of inhalable dust Radiation Waste Characterisation Report, Radiation Professionals, 2016
- Guidance on the Interpretation of Workplace Exposure Standards for Airborne Contaminants, SafeWork Australia, 2012
- Radiation waste characterisation report, Radiation Professionals, 2016
- Radiation Impact Assessment, JRHC Enterprises Pty. Ltd, 2016
- Radioactive Waste Management Plan, Hastings, 2016

11 GLOSSARY

Bq	Becquerel – 1 decay per second (DPS)
CPS	Count per second (detected)
DMP	Western Australian Department of Mines and Petroleum
DPS	Decay per second
MSIA	Mines Safety and Inspection Act, 1994
MSIR	Mines Safety and Inspection Regulations, 1995
RMP	Radiation Management Plan
RSA	Radiation Safety Act, 1975
RSO	Radiation Safety Officer
RS(G)R	Radiation Safety (General) Regulations, 1983
SEG	Similar Exposure Group
SME	State Mining Engineer as per MSIA
SMS	Safety Management System
Th	Thorium
U	Uranium

12 COMMITMENTS (RADIATION SAFETY POLICY)

Several commitments have been made throughout this RMP, which are summarised below.

In accordance with requirements of regulation 16.7(4) of the Mines Safety and Inspection Regulations (1995) the Plan will be reviewed within two years of the submission or at intervals designated by the State Mining Engineer.

More frequent reviews will be carried out in accordance with regulation 16.7(6) when the "plan for the mine is amended".

12.1 PRE-OPERATIONAL TRANSPORT BASELINE SURVEY

A pre-operational gamma-radiation survey along the current transport route has been carried out and the levels are currently monitored to determine any increase in radiation levels. If the transport route is altered the same monitoring process would continue following pre-operational surveys on the new route.

The pre-operational gamma radiation surveys have been carried out at all registered premises and radiation levels will continue to be monitored.

12.2 REVIEW OF RMP

The RMP will be progressively analysed and modified as current operational data becomes available and where possible estimated data will continue to be replaced by actual data.

The RMP will also be revised should future production rate and/or processing methods change significantly in comparison with those detailed in section 4.3, Figure 3. Any proposed changes to the RMP will be submitted to the State Mining Engineer for approval.

12.3 RESTRICTED AREA AND PERMIT TO WORK

If any special works involving handling of material where higher than usual exposures may be expected, the radiation safety officer will develop a Work Permit System for the minimisation and monitoring of personal radiation exposures.

12.4 RECORD KEEPING

A comprehensive record keeping system is established and will be maintained in accordance with Hastings recording procedure.

12.5 RADIATION SAFETY REVIEW & REPORTING

A review of the RMP will be carried out every two years in accordance with the DMP regulations and guidelines.

Two annual reports on the results of radiation monitoring and on the implementation of the RMP will be submitted to the State mining engineer:

- Occupational radiation monitoring report, for the April-March period, in May; and
- Environmental radiation monitoring report, for the October-September period, November.

12.6 RADIATION MONITORING

All monitoring will be carried out as described in section 6.

12.7 REVIEW OF RMP ASSUMPTIONS

Considerations and amendments to the current radiation monitoring program will become effective post construction and once actual monitoring data becomes available regarding radiation hazards and exposures.

12.8 CONTAMINATION CONTROL

Decontamination of vehicles and equipment used in controlled areas or involved with haulage and deposition of ore or tailings will be subject to current vehicle decontamination protocols

12.9 STORMWATER MANAGEMENT

Rainwater runoff from the ore stockpiles and around the processing plant is managed via the Radioactive Waste Management Plan (Hastings, 2016)

APPENDIX 1. SUBSIDIARY PROCEDURES AND FORMS

1. Radiation safety induction work instruction
 - 1.1. Radiation monitoring equipment pre-start work instruction

2. Vehicle/equipment clearance procedure
 - 2.1. Vehicle/equipment clearance form

3. Occupational radiation dose monitoring procedure
 - 3.1. Personal gamma dosimeter (TLD/OSL) work instruction
 - 3.2. Personal air sample and counting work instruction
 - 3.3. Radon/Thoron monitoring work instruction
 - 3.4. Water sampling & testing procedure

4. Environmental radiation monitoring procedure
 - 4.1. Operation & boundary gamma monitoring work instruction
 - 4.2. Water (ground & surface) monitoring work instruction
 - 4.3. Hi-Vol boundary and critical group work instruction

5. Annual reporting procedure
 - 5.1. Personal gamma dose assessment work instruction
 - 5.2. Airborne adps dose assessment work instruction
 - 5.3. Radon/Thoron dose assessment work instruction
 - 5.4. Ingestion (Water) dose assessment work instruction

APPENDIX 2. INVESTIGATION AND ACTION LIMITS

Reproduced from the DMP, NORM Guideline, 2010.

Radiation parameter	Investigation level	Comment
Site boundary	More than 0.11 $\mu\text{Gy/hr}$ above background	> 1 mSv/year for a member of the public (8760 hours/year)
Supervised area	More than 0.50 $\mu\text{Gy/hr}$ above background	> 1 mSv/year for an employee (2000 hours/year)
Controlled Area	More than 2.50 $\mu\text{Gy/hr}$ above background	> 5 mSv/year for an employee (2000 hours/year)
Restricted	More than 7.50 $\mu\text{Gy/hr}$ above background	> 15 mSv/year for an employee (2000 hours/year)
Designated worker external dose	> 2.5 mSv in a quarter	> 10 mSv/year
Designated worker internal dose	>5 mSv in a quarter	Assessed from air sampling
Non-designated worker external dose	> 0.5 mSv in a quarter	> 2 mSv/year
Total alpha activity on the personal air sample - U dust	> 9.9 Bq/m ³ for 12-hour shift sample	> 0.5 mSv/shift
Total alpha activity on the personal air sample - Th dust	> 4.3 Bq/m ³ for shift sample	> 0.5 mSv/shift
Total alpha activity on the personal air sample - U dust	4 consecutive samples > 2.4 Bq/m ³	Indicates potential for significant exposure
Total alpha activity on the personal air sample - Th dust	4 consecutive samples >1.0 Bq/m ³	Indicates potential for significant exposure
Total alpha activity	> Mean + 3 std deviations	Indicates potentially unusual working conditions
Total alpha activity on environmental air sample - U dust	> 2 mBq/m ³ on high volume air sampler	> 100 $\mu\text{Sv/year}$ for a member of public continuously exposed. (>10% of exposure limit)
Total alpha activity on environmental air sample - Th dust	> 1 mBq/m ³ on high volume air sampler	> 100 $\mu\text{Sv/year}$ for a member of public continuously exposed. (>10% of exposure limit)
226Ra in ground water or surface water	> 0.5 Bq/L 226Ra or 2 average pre-operational levels for waters containing naturally high levels of radium	100 $\mu\text{Sv/year}$ for ingestion of 2 L/day for year.
228Ra in ground water or surface water	> 0.2 Bq/L 228Ra or 2 average pre-operational levels for waters containing naturally high levels of radium	100 $\mu\text{Sv/year}$ for ingestion of 2 L/day for year.
Low toxicity alpha emitters (238U, 232Th, 228Th, 230Th) on a surface	>0.4 Bq/cm ²	Averaged over 300 cm ² . Non-fixed - can be removed from surface during handling

APPENDIX 3. PROPOSED SUPERVISED AND CONTROLLED AREAS

The proposed supervised and controlled areas are subject to final design of mining operations. The mine pit is also inside a supervised area but is not shown on this drawing.

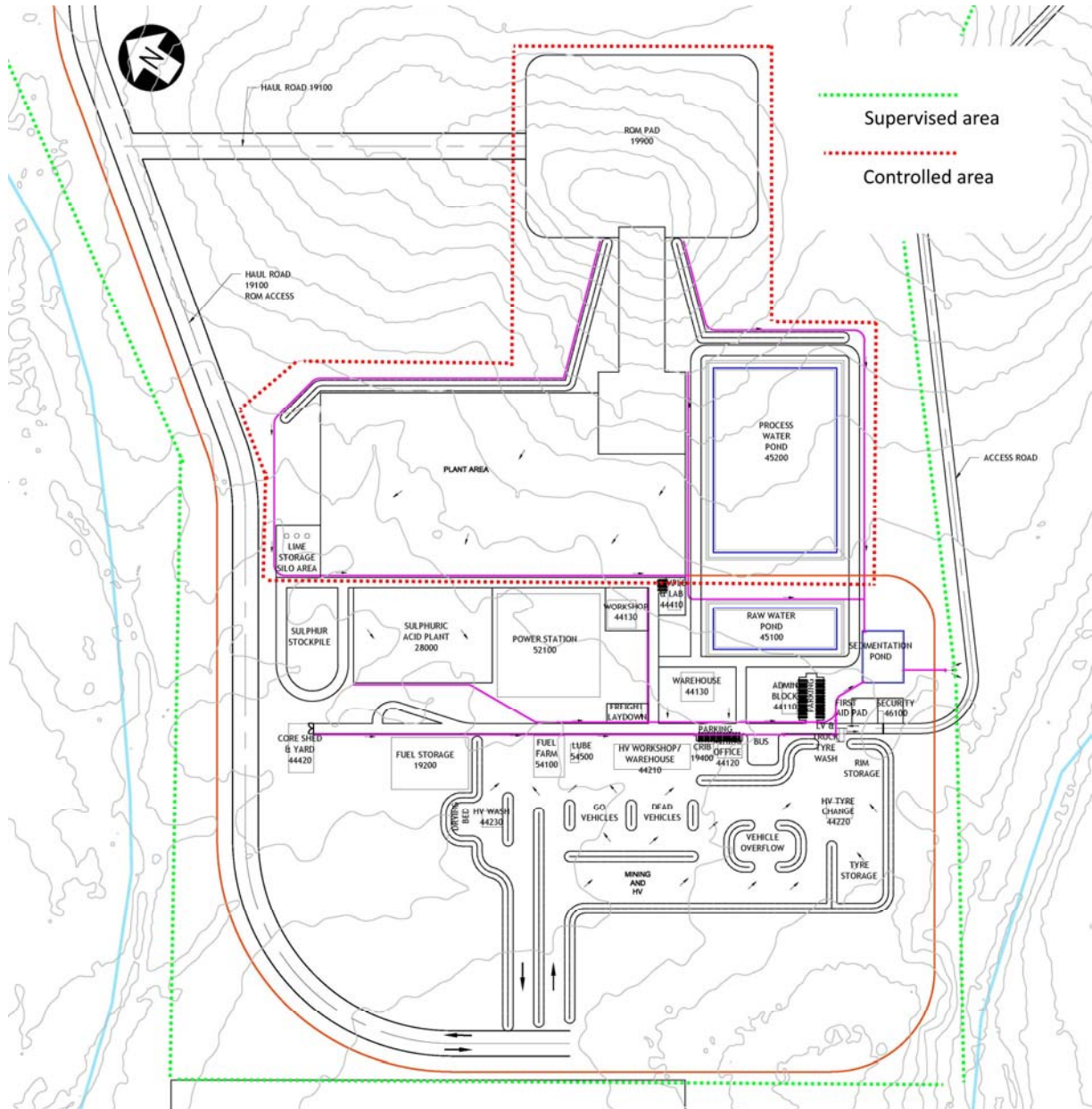

FIGURE 7 PROPOSED SUPERVISED AND CONTROLLED WORK AREAS

APPENDIX 4. TECHNICAL NOTE: ENVIRONMENTAL SUMMARY



HASTINGS
Technology Metals Limited

Yangibana Rare Earths Project

TECHNICAL NOTE

Environment

Document	Technical Environment	Note:		Division	App	Status	Approved	Issued	9/12/16
Number				Author	LJ	Review Date	9/12/16	Version	0

1 Introduction

1.1 Yangibana Rare Earths Project

Hastings Technology Metals Limited (Hastings) is proposing to develop the Yangibana Rare Earths Project (the Project), which is situated approximately 270 km north-east of Carnarvon and approximately 100 km north-east of Gascoyne Junction, in the upper Gascoyne region of Western Australia (Figure 1). Hastings is targeting rare earth elements in ferrocarnatite veins in four deposits. An on-going exploration program across Yangibana tenements may discover other feasible deposits to mine. An open cut mining method will separate waste rock and ore. Waste rock landforms will be situated next to each pit. The ore will undergo processing: Beneficiation and Hydrometallurgy. Tailings from the process plant will be directed to Tailings Storage Facilities.

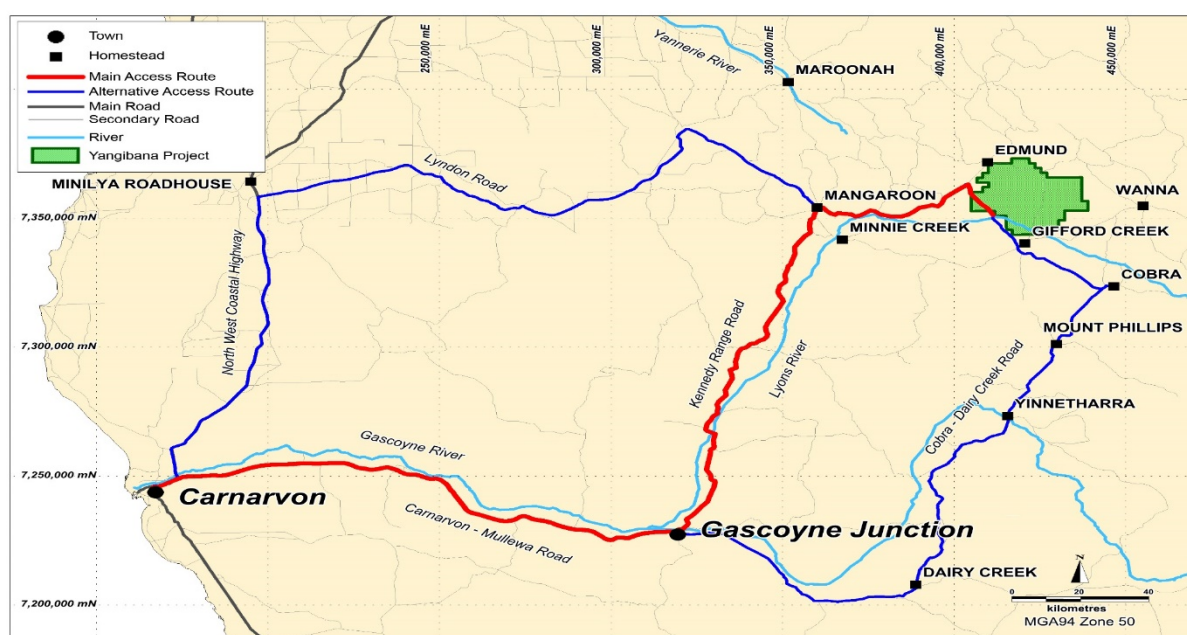

Figure 1 Location of the Yangibana Rare Earths Project

1.2 SCOPE

The purpose of this technical note is to provide an overview of the surrounding environmental values for the Project, with a focus on those aspects relevant to the management of radionuclides.

Specific environmental values considered include:

- Climate (Section 2)
- Terrain (Section 3)
- Soils (Section 4)
- Vegetation (Section 5)
- Hydrology (Section 6)

1.3 Relevant Documentation

This report should be read in conjunction with the following documentation should additional information or clarification be required:

- Vegetation and Flora Assessment Report (Ecoscape 2016a);
- Subterranean Fauna Assessment Reports (Ecoscape 2016b);
- Soils Assessment (Landloch 2016);
- Conceptual Hydrogeological Assessment (Global Groundwater 2016); and
- Preliminary Hydrology Report (JDA 2016).

2 Climate

The climate (as described by Ecoscape 2016a) is arid to semi-arid. Cool day time temperatures occur over winter and warm to hot day time temperatures occur over summer. The Project occurs in the low rainfall (less than 350 mm) zone and warm humid summer climate zone based on temperature and humidity (Figure 2). A number of climatic influences impact the area causing bi-modal average rainfall with an average annual total of about 220 mm. These climatic influences include the west coast trough, northwest cloudbanks, tropical cyclones, frontal systems and subtropical ridge.

A more detailed description of climate is provided in Ecoscape (2016a).

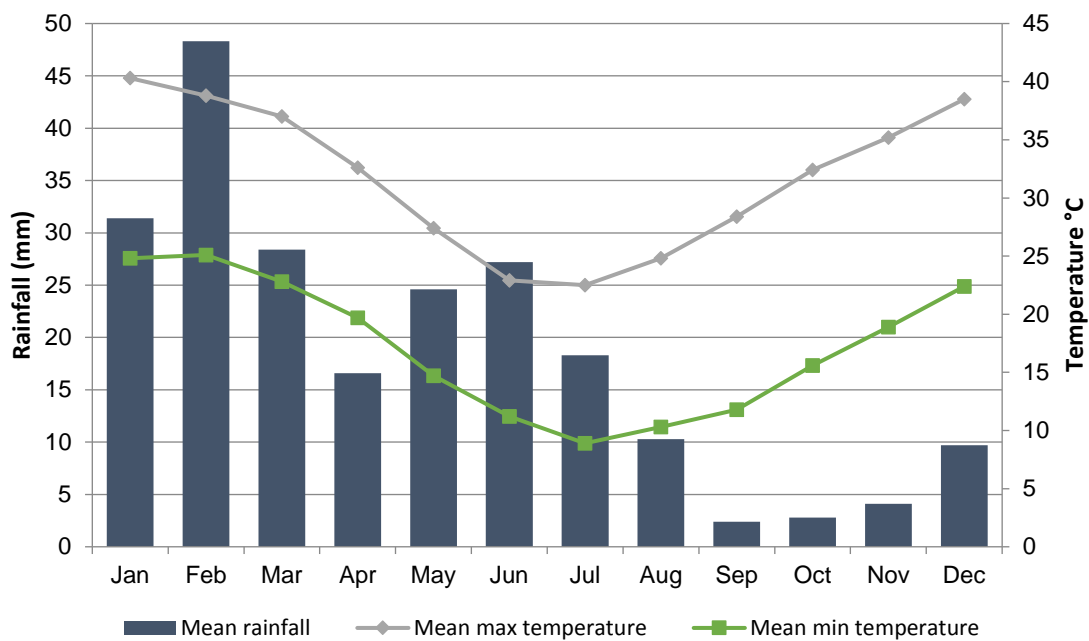

Figure 2 Monthly rainfall and daily maxima and minima for Mt Phillip (BoM 2015b) located approximately 70km south of the Yangibana Rare Earths Project (from Ecoscape 2016a).

3 Terrain

Ecoscope (2016a) describe the Project using the Interim Biogeographical Regionalisation for Australia (IBRA) (Department of the Environment [DoE] 2014a), which occurs within the Gascoyne region. Three major subregions, namely Ashburton, Augustus and Carnegie (Thackway and Cresswell 1995), occur within the Gascoyne region. The Project occurs within the Augustus subregion, which is described as:

Rugged low Proterozoic sedimentary and granite ranges divided by broad flat valleys. Also includes the Narryera Complex and Bryah Basin of the Proterozoic Capricorn Orogen (on northern margin of the Yilgarn Craton), as well as the Archaean Marymia and Sylvania Inliers. Although the Gascoyne River System provides the main drainage of this subregion, it is also the headwaters of the Ashburton and Fortescue Rivers. There are extensive areas of alluvial valley-fill deposits. Mulga woodland with Triodia occur on shallow stony loams on rises, while the shallow earthy loams over hardpan on the plains are covered by Mulga parkland. A desert climate with bimodal rainfall. The subregional area for GAS3 is 10,687,739 ha (Desmond et al. 2001).

Global Groundwater (2016) describe the bulk of the Project area being *underlain by granitic rocks characterised by subdued topography with some broad open flats and occasional rounded granitic hills with elevations to about 350 m AHD.*



Figure 3 Yangibana Rare Earths Project terrain

4 Soils

The broader Project area is located within the Gascoyne Province of the Capricorn Orogen. Proterozoic metasedimentary basement rocks of the Pooranoo Metamorphics underlie the broader Project area, which consist of metamorphosed feldspathic sandstone and psammitic schist and calc-silicate rocks. These have been intruded by Proterozoic granitic rocks (specifically the Pimbyana and Yangibana Granites), which are fresh to weathered (Global Groundwater 2016).

Global Groundwater (2016) further describe the geology as follows:

The earlier basement rocks have been intruded by later dolerite sills and dykes as well as veins of ferrocarnatite, ironstone and quartz of the Gifford Creek Ferrocarnatite Complex (GFC) as described by Piranjo and Gonzalez-Alvarez (2013). The ironstone veins have shallow (c. 10°) to steep (c. 65°) dips, consist of magnetite, hematite, and supergene goethite and are locally weakly radioactive. Lenses and pods up to 10 m wide of massive to vuggy iron oxide are contained within the veins. These are considered to have resulted from later alteration of intruded ferrocarnatites by hydrothermal iron oxides and then subject to supergene alteration closer to the surface to produce massive goethite and gossanous outcrop (Piranjo and Gonzalez-Alvarez. 2013). They host the rare earth element (REE) mineralisation of the proposed development, and occur as sinuous pods and veins generally less than 10 m wide, that are traceable for up to 25 kilometres (Whittock, 2016).

Landloch (2016) defined and mapped the soils as Hill Soil and Plain Soil. Hill Soil is associated with the extensive granite geology that forms the low hills and rises across the site. Hill Soils are typically associated with extensive stone mantles and outcrops of granite and ironstone. The TSFs will be located on Hill Soils. A summary of the characteristics of Hill Soils are shown in Table 1 and further described by Landloch (2016). Plain Soils are found on low relief areas associated with the drainage lines across the Project area.

Table 1 Characteristics of Hill Soils (Landloch 2016a)

Property	Inspection Site Description	
<i>Brief description</i>	Shallow dark brown sandy loam duplexes	
<i>Extent</i>	17,613.7ha (mapped)	
<i>Soil samples</i>	Pit 1 to 5, 7 to 14, 16 to 19	
<i>Gradient</i>	Gently undulating to low rises	
<i>Soil Landscape</i>	James, Agamemnon, Glenburgh	
<i>Soil classification</i>	Brown shallow loamy duplex ^A / Brown Chromosol ^B	
<i>Surface coarse fragments</i>	50–100% abundance, sub-angular pebbles to rocks of granite, ironstone, and quartz origin	
<i>Surface condition</i>	Soft to moderate	
<i>Permeability*</i>	Slow to Moderate	
<i>Water repellent*</i>	No	
<i>Drainage*</i>	Sheet wash and distinct drainage lines between hills	
Soil depth (cm)	Soil Profile Description	
0–5	A ₁ : Dark brown (2.5YR-2.5/3), weakly structured, sandy loam, <10% coarse pebble fragments, pH 6.5 (field)	
5–20	B ₁ : Dark brown (2.5YR-2.5/4), weakly pedal, loam to clay loam, <5% coarse fragments, pH 6 (field)	
20–40	B ₂ : Dark brown (2.5YR-2.5/4), weakly pedal, clay loam, <5% coarse pebble fragments, pH 6 (field)	
>40	C Decomposing grey granite (but also red/yellow)	

Vegetation communities associated with the soil types also differed. Hill Soils were associated with scattered low woodlands and shrublands of mulga/acacia species with grasses while Plain Soils had extensive bare sandy patches in low resource areas with scattered grass and shrubs in higher resource areas. Eucalypt and acacia species were noted along drainage lines. Further delineation of vegetation is described by Ecoscape (2016a) and in Section 5 below.

5 Vegetation

The vegetation association identified by Ecoscape (2016a) over the area of the process plant and TSFs is 'Low woodland; mulga and snakewood (*Acacia eremaea*)', as defined by Beard (1970). Twenty vegetation types were recorded from the study area. Specifically, two vegetation types, which occur within or in the near vicinity of the TSF footprint, are described as:

- EpAc: *Eremophila phyllopoda* subsp. *obliqua*, *Acacia tetragonophylla* and *Senna artemisioides* subsp. *helmsii* mid open shrubland over *Aristida contorta*, *Eriachne pulchella* subsp. *dominii* and *Portulaca oleracea* low grassland/forbland.
- EeAc: *Eremophila exilifolia*, *Acacia tetragonophylla* and *A. kempeana* mid open shrubland over *Aristida contorta* and *Eriachne pulchella* subsp. *dominii* low sparse tussock grassland.

A total of 472 vascular flora taxa were recorded in the Study Area (55,000 ha). No threatened flora listed under the EPBC Act (Cwth) and *Wildlife Conservation Act 1950* (WC Act) (WA) were recorded in the study area. Eight priority flora listed under the WC Act were recorded in the study area:

- *Acacia curryana* (listed as a Priority 1 (P1) taxon by the WA DPaW);
- *Rhodanthe frenchii* (P2);
- *Solanum octonum* (P2);
- *Wurmbea fluviatilis* (P2);
- *Gymnanthera cunninghamii* (P3);
- *Sporobolus blakei* (P3);
- *Goodenia berringbinensis* (P4); and
- *Goodenia nuda* (P4).

The Project will impact upon two priority flora species, namely *Acacia curryana* and *Rhodanthe frenchii*.

58 taxa were recorded as having significant range extensions or filling substantial range gaps in species distribution. Additionally, one undescribed species (*Elacholoma* sp. 'Showy Flowers') was recorded in the study area but outside the Project development envelope. The proposed action will not impact this species.

Twenty-four introduced species (weeds) were recorded within the study area. Of these, *Argemone ochroleuca* (Mexican Poppy) and *Datura leichhardtii* (Thornapple) are Declared Pests listed under the *Biosecurity and Agriculture Management Act 2007* (WA).

Surface groundwater dependent ecosystems are associated with drainage lines, creeks and rivers in the near vicinity of the Project area (Ecoscape, 2016a). However, none occur within the footprint of the TSFs or processing plant. Associated with these is the Gifford Creek Priority Ecological Community, which is characterised by a network of shallow calcrete aquifers, typical habitat of subterranean fauna. The Project area intersects the northern portion of the PEC. Subterranean fauna have been found within drill holes intersecting the resource (see Ecoscape, 2016b for further information).

6 Hydrology

6.1 Surface Water

The Project area is located within the Gascoyne River catchment. The catchment area of the Lyons River to this crossing location is approximately 11,000 km² (JDA 2016). The catchment extends approximately 200 km east from the Study Area.

The Lyons River, a tributary of the Gascoyne River, is associated with the southern portion of the broader Project area, and flows in a general northwestern direction. The Lyons River is considered to be ephemeral, i.e. only flows after rainfall. Semi-permanent waterholes occur within the Lyons River in the general vicinity of the Project area.

Several tributaries of the Lyons River traverse the Project area, namely Yangibana and Frasers Creeks. There are also several drainage channels within the Project area. The TSFs do not intersect the Lyons River nor the creeks.

A detailed hydraulic model was developed for Fraser, Yangibana and Gifford Creeks, as well as the Lyons River adjacent to the Study Area to assess flood conditions that are likely to impact on the proposed mine infrastructure (JDA 2016). This model used rainfall on grid for the creek catchments, and includes flow in the Lyons River based on the larger Lyons River hydrological model. The detailed model allows for accurate delineation of flood extent, depth, flow rates and velocities, which will be used to inform mine design.

The impact of regional and local flood waters on the proposed mine infrastructure has been assessed by JDA (2016; Figure 4 represents the worst case outcomes from a 100 yr ARI over a 6 hour period). Based on JDA's assessment (2016) a combination of diversion channels, floodways and culverts are required to mitigate impacts associated with surface water flows in the Project area.

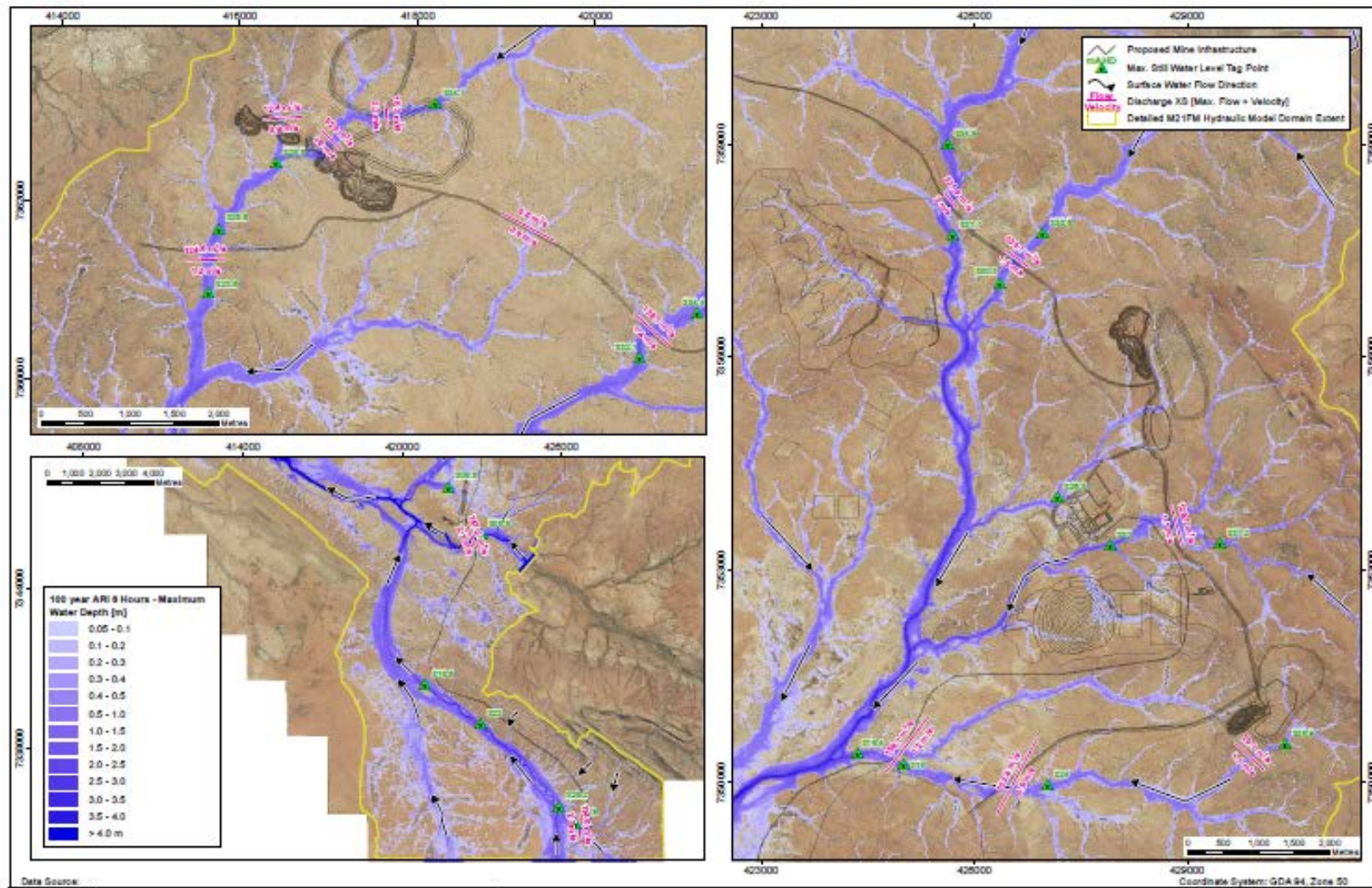

Figure 4 Modelling of surface water flows for a 100 ARI (6 hours) (JDA 2016)

6.2 Groundwater

The Project area is not characterised by regional aquifers. Global Groundwater (2016) report that aquifers are likely to be present in superficial strata (where sufficiently thick and saturated) or in basement rocks where fractured (Figure 5). However, these will be isolated and effectively disconnected from each other over much of the area. Some degree of hydraulic connectivity will occur locally depending on geological structure, weathering, landscape position and aquifer geometry (Global Groundwater 2016).

Geological profiling, topography and soils assessments define the area on which TSFs will be located to be basement rocks. Basement rocks in the study area have very low permeability and could be regarded as effectively impermeable throughout much of the area (Global Groundwater 2016). However, some zones of very high permeability will occur i.e. in the vicinity of bedding plane partings and fractures from faulting, folding, intrusives and where solution cavities and channels (vugs) have developed in ironstone veins (Global Groundwater 2016). These zones of high permeability occur where the target resource will be mined.

Groundwater from intake areas will flow down hydraulic gradients, most likely in the direction of surface water flow (Global Groundwater 2016). Regional flow systems are not likely to be generated. Local flow systems will have established in response to aquifer distribution and geometry, which is highly variable.

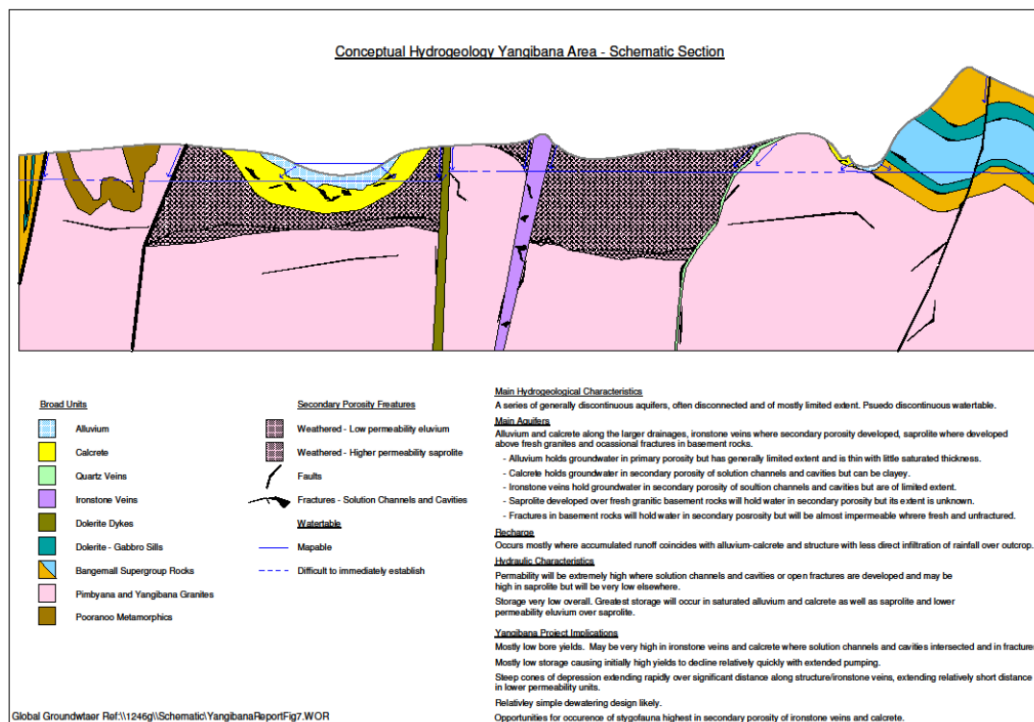

Figure 7. Conceptual Hydrogeology - Schematic Section

Figure 5 Conceptual Hydrogeology of the Yangibana Rare Earths Project area (Global Groundwater 2016)

7 References

Ecoscape. 2016a. *Yangibana Rare Earths Project Vegetation and Flora Assessment Report*. A report prepared by Ecoscape for Hastings Technology Metals Ltd.

Ecoscape. 2016b. *Yangibana Rare Earths Project Subterranean Fauna Assessment*. A report prepared by Ecoscape for Hastings Technology Metals Ltd.

Global Groundwater. 2016. *Yangibana Rare Earths Project Conceptual Hydrogeological Assessment*. A report prepared by Global Groundwater for Hastings Technology Metals Ltd.

JDA and Associates. 2016. *Yangibana Rare Earths Project Surface Water Assessment*. A report prepared by JDA and Associates for Hastings Technology Metals Ltd.

Landloch 2016a. *Yangibana Rare Earths Project Soils Assessment*. A report prepared by Landloch for Hastings Technology Metals Ltd.

APPENDIX 5. TECHNICAL NOTE: GEOLOGICAL SUMMARY



HASTINGS
Technology Metals Limited

Yangibana Rare Earths Project

TECHNICAL NOTE

Geology: Radionuclides

Document	Technical Note: Geology		Division	GEO	Status	Approved	Issued	9/12/16
Number			Author	AB	Review Date	27/10/16	Version	0

1. Exploration Targets

Hastings Technology Metals Limited has conducted rare earths exploration drilling at current known and named deposits and prospects within the Yangibana Project (Figure 1). The well explored targets with JORC Indicated Resources are at Bald Hill South, Fraser’s and Yangibana West within tenements in which Hastings holds 100% interest, and Yangibana North in which it holds a 70% interest. JORC Inferred Resources have been defined at Gossan, Lion’s Ear, Hook, Kane’s Gossan and Bald Hill North, in each of which Hastings has a 70% interest. Drilling in 2016 has tested the Auer, Auer North, Demarcay, Mosander and Hatchett targets and it is expected that JORC resources will be defined at Auer and Auer North in Q4 2016. Hastings undertook limited drilling at Yangibana, Yangibana South and Terry’s Find during 2015 but insufficient to justify resource estimation. Limited historical drilling has tested Fraser’s prospect, while no drilling has yet occurred at Turbine, Spider Hill or Simon’s Find.

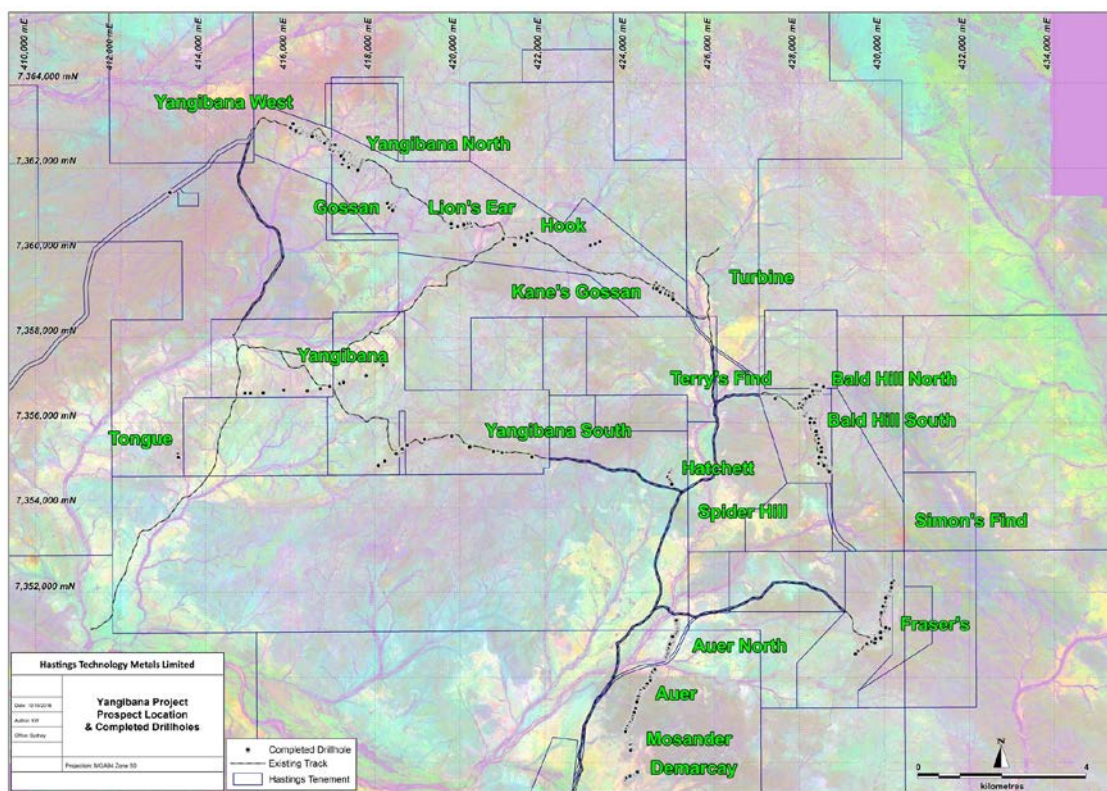

Figure 1 Yangibana Project, location of defined rare earths targets

2. Radiometric survey

Thorium radiometric data was collected from the 2016 aeromagnetic and radiometric survey commissioned by Hastings and interpreted by Southern Geoscience Consultants Pty Limited (SGC; Figure 2). This survey identified a number of new targets that will be assessed over the coming years.

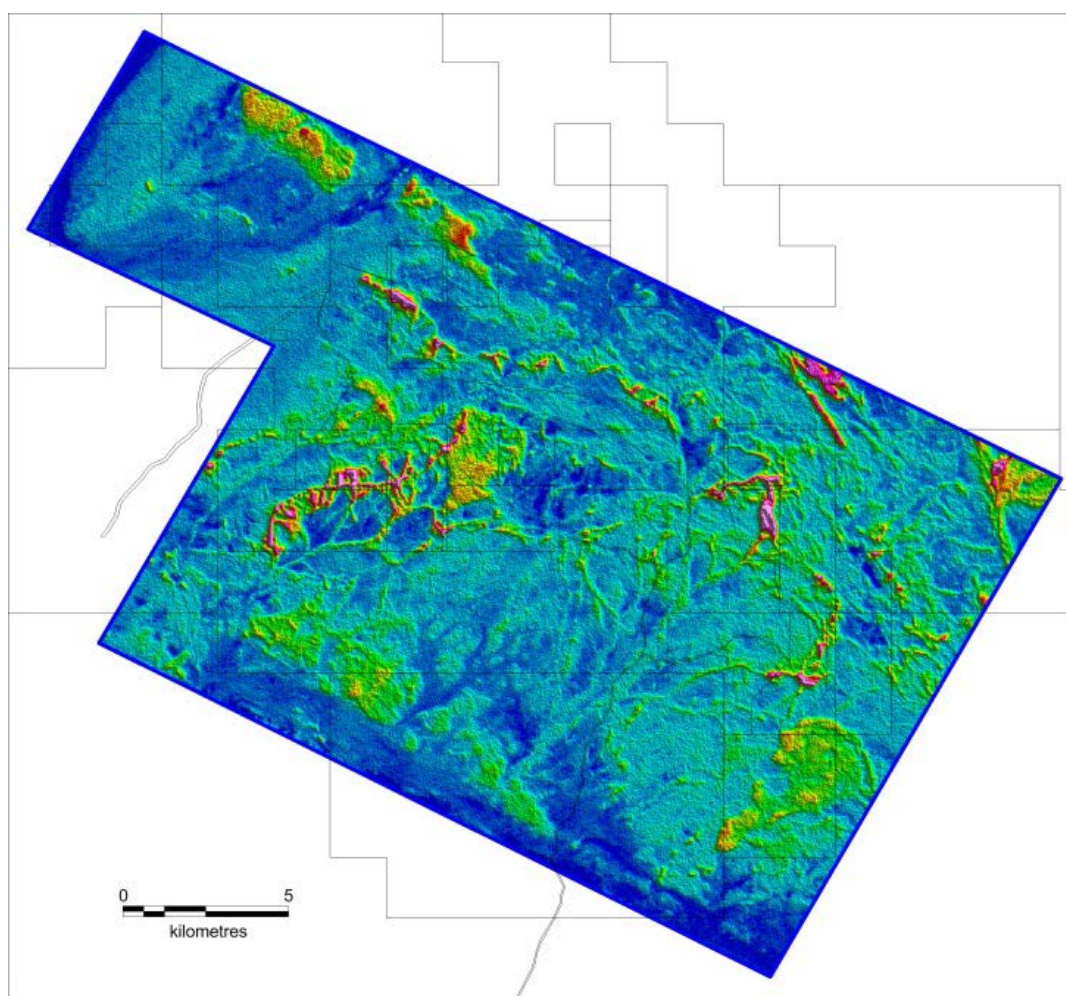

Figure 2 Yangibana Project, thorium radiometric image

The rare-earths bearing ironstone units are well defined by the thorium data due to the host mineral being monazite. In particular, the semi-continuous belt of ironstone between Yangibana North and Kane's Gossan; the ironstone at Bald Hill South and its continuing trend south to Fraser's ironstone; and the ironstone belt that extends from east of Yangibana prospect to Tongue prospect, show extremely well in this data. The broad zones around particularly Bald Hill South and Yangibana-Tongue relate to the large quantities of ironstone scree at these sites and the concentration of finer ironstone scree in the small creeks flowing from them.

3. Ore

The Yangibana rare earths mineralisation is associated with rocks of the Gifford Creek Ferrocarbonatite Complex (GCFC). The GCFC is a high-level, carbonatite-associated igneous intrusive suite that includes localities such as the Yangibana ironstones (shown as Targets 1-10 in Figure 3) and ferrocarbonatites, the Spider Hill ring intrusion (Target 11 in Figure 3), and the Bald Hill intrusions. It is characterised by ferrocarbonatite dykes, veins and sills and surrounded by fenitised (due to wallrock metasomatism) country rocks, which are generally southeast to east-southeast trending. They consist of dolomite, ankerite and siderite with accessory minerals that include magnetite, and the REE-bearing mineral phosphate monazite [usually (Ce,La,Nd)PO₄].

Sinuuous ironstone veins and pods (mainly magnetite, hematite and goethite) are spatially associated with (but likely post-date) the ferrocarbonatite intrusions. They are north-northeast to east-southeast trending, surrounded by narrow haloes of fenitic alteration and are locally anomalously radioactive.

Based on resource estimations the overall average values for the mineralisation within the Yangibana Project is 25ppm U₃O₈ and 450ppm ThO₂¹.

¹ The samples were analysed for U and Th and converted to oxides.

4. WASTE ROCK ANALYSES

As a matter of course Hastings has sampled the hanging wall and footwall units within a few metres of the mineralisation in all holes at all targets tested. All these intersections have been assayed for thorium and uranium as well as the target rare earths and other selected elements.

In early 2015 Hastings undertook a limited programme of random sampling of material from the 2014 drilling programmes at Yangibana North and Bald Hill South. These samples provide analyses of material in the hangingwall well away from the mineralised zones.

Table 1 shows the number of samples taken from each area and the mean ThO₂ and U₃O₈ values derived from those analyses. Samples from drilling have been spilt into those that are immediately adjacent to the mineralisation (usually only 1-2m wide) and are marginal carrying between 0.1 and 0.2% total rare earths oxides, and those slightly further from the mineralisation and carrying less than total rare earths oxides.

Table 1 Yangibana Project, mean ppm ThO₂ and U₃O₈ values for waste rock samples

	Waste <0.1%			Waste <0.2%			HW samples		
	No.	ThO ₂	U ₃ O ₈	No.	ThO ₂	U ₃ O ₈	No.	ThO ₂	U ₃ O ₈
Bald Hill South	375	36	7	1645	81	10	10	33	11
Fraser's	234	30	8	480	57	10			
Yangibana North	185	25	6	497	78	9	54	24	6
Yangibana West	293	30	5	317	91	8			
Auer	20	41	4						

These results clearly indicate an increase in thorium levels within 1-2m of the mineralisation to means of 57-91ppm ThO₂. This figure drops off rapidly away from the mineralisation to means of 24-41 ppm ThO₂.

Uranium levels are consistently low with means of 8-10ppm U₃O₈ within 1-2m of the mineralisation and 4-8 ppm U₃O₈ slightly further away. A higher mean of 11ppm U₃O₈ in the hangingwall samples from Bald Hill South relates to the background values of the granite.

APPENDIX 6. RADIATION WASTE MANAGEMENT PLAN



HASTINGS
Technology Metals Limited

10 December, 2016



Radiation Waste Management Plan



Revision 0

Table of Contents

Executive Summary.....	3
1 Introduction	4
1.1 Overview	4
1.2 Scope	4
1.3 Objective	5
1.4 Key Elements	5
1.5 Supporting Documentation.....	6
1.6 Relevant Legislation	7
2 Background	8
2.1 Processes generating waste	8
2.1.1 Mining.....	8
2.1.2 Processing.....	8
2.2 Description of waste	8
2.2.1 Nature of material (chemical, physical and radiological).....	8
2.2.2 Contaminants	9
2.2.3 Quantities and rate of production.....	9
2.3 Description of environment	10
2.4 Baseline radiological characteristics	10
2.4.1 Gamma radiation.....	11
2.4.2 Radionuclides in dust.....	11
2.4.3 Radon and thoron concentrations	11
2.4.4 Radionuclides in soil	12

2.4.5	Radionuclides in water (surface and groundwater)	13
2.5	Heritage	14
2.5.1	Aboriginal	14
2.5.2	European	14
2.6	Land use (present and potential)	15
3	Management.....	16
3.1	Risk Assessment	16
3.2	Mitigation of Risk	17
3.2.1	Design criteria	17
3.2.2	Construction and operations.....	19
3.2.3	Decommissioning and Closure.....	21
4	Monitoring	24
4.1	Pre-operational monitoring.....	24
4.2	Operational monitoring.....	24
4.2.1	Sources.....	25
4.2.2	Containment Controls	26
4.2.3	Trigger values	26
4.2.4	Quality Assurance.....	28
5	Contingency Planning	30
6	Reporting.....	31
6.1	Documentation	31
6.2	Incidents	32
7	Review	33
8	References	34

Document	RWMP		Division	ENV	Status	o	Issued	
Number			Author	LJ	Review Date		Version	

9 Appendices36

Appendix A: Technical Note - Summary of Environment36

Appendix B: Technical Note – TSF 2 and 3 Closure Considerations**Error!**
Bookmark not defined.

Document	RWMP		Division	ENV	Status	0	Issued	
Number			Author	LJ	Review Date		Version	

1 Introduction

1.1 Overview

Hastings Technology Metals Limited (Hastings) is proposing to develop the Yangibana Rare Earths Project (the Project), which is situated approximately 270 km north-east of Carnarvon and approximately 100 km north-east of Gascoyne Junction, in the upper Gascoyne region of Western Australia (Figure 1). Hastings is targeting rare earth elements in ferrocarnatite veins in four deposits. An on-going exploration program across Yangibana tenements may discover other feasible deposits to mine. An open cut mining method will separate waste rock and ore. Waste rock landforms will be situated next to each pit. The ore will undergo processing: Beneficiation and Hydrometallurgy. Tailings from the process plant will be directed to Tailings Storage Facilities.



Figure 1 Location of the Yangibana Rare Earths Project

1.2 Scope

The mineralized zone of the target ore body at the Project contains radionuclides. During processing, these radionuclides become concentrated in two of the three tailings waste streams. The radioactive tailings comprise less than 9% of the total tailings. This Radioactive Waste Management Plan (RWMP) describes how radioactive waste, generated from processing streams, will be managed at the Project.

Document			Division		Status	Approved	Issued	
Number			Author		Review Date		Version	

This RWMP meets the requirements set out in the following documents:

- *Code of Practice for Radiation Protection and Radioactive Waste Management in Mining and Mineral Processing* (ARPANSA 2005) (the Mining Code); and
- *Managing naturally occurring radioactive material (NORM) in mining and mineral processing guideline. NORM 4.2. Management of radioactive waste* (Department of Mines and Petroleum 2010) (NORM Guideline 4.2).

This RWMP will form a component of the Yangibana Environmental Management System (EMS), which operates on a continual improvement cycle of plan, do, check and act. This RWMP is considered a 'live' document and will be further reviewed during the Detailed Engineering Design phase when the Project will be further refined, and defined in greater detail. Formal approval of this document will be sought from the Department of Mines and Petroleum and Radiological Council prior to the operations phase of the Project.

1.3 Objective

The objective of this RWMP, as stated in the Mining Code (ARPANSA 2005) is to:

“...ensure that there is no unacceptable health risk to people, both now and in the future, and no long-term unacceptable detriment to the environment from the waste so managed, and without imposing undue burdens on future generations.”

1.4 Key Elements

The key elements of this RWMP (as set out in NORM Guideline 4.2) include:

- An outline of the processes generating waste (Section 3 Background).
- A description of waste including nature of material (chemical, physical and radiological), contaminants, and quantities and rate of production (Section 3 Background).
- A description of the environment into which the waste will be discharged or disposed (climate, terrain, soils, vegetation, hydrology), including the baseline radiological characteristics (Section 3 Background).
- Heritage (social and cultural) and land use (present and potential) (Section 3 Background).
- A description of the proposed system for waste management including the facilities and procedures involved in the handling, treatment, storage and disposal of radioactive waste (Section 4 Management).
- Predictions of environmental concentrations of radionuclides and radiation doses to the public from the proposed waste management practice, including demonstration that the statutory radiation protection requirements will be met both now and in the future (Section 4 Management).

Document	RWMP		Division	ENV	Status	o	Issued	
Number			Author	LJ	Review Date		Version	

- A program for monitoring the concentration of radionuclides in the environment and assessment of radiation doses to members of the public arising from the waste management practices (Section 5 Monitoring).
- Contingency plans for dealing with accidental releases and the circumstances which might lead to uncontrolled releases of radioactive waste in the environment (Section 6 Contingency Planning).
- Contingency plan to cover cases of early shutdown or temporary suspension of operations (Section 6 Contingency Planning).
- A schedule for reporting on the waste disposal operation and results of monitoring and assessments (Section 7 Reporting).
- A plan for the decommissioning of the operation and associated waste management facilities, and for the rehabilitation of the site (Section 4 Management).
- A system of periodic assessment and review of the adequacy and effectiveness of the RWMP to take account of potential improvements consistent with best practicable technology (Section 8 Review).

1.5 Supporting Documentation

Documentation that should be read in conjunction with and complement this RWMP include:

- Baseline Radiation Report (Radiation Professionals, 2016a);
- Radiation Waste Characterisation Report (Radiation Professionals, 2016b);
- Construction and Operations Radiation Management Plans (Dean Crouch, 2016);
- Cultural Heritage Management Plan (Ecoscape 2016a);
- Mine Closure Plan (Ecoscape 2016b);
- Vegetation and Flora Assessment Report (Ecoscape 2016c);
- Subterranean Fauna Assessment Reports (Ecoscape 2016d);
- Soils Assessment (Landloch 2016a);
- Waste rock characterisation (Landloch 2016b and Trajectory and Graham Campbell and Associates 2016);
- Air Quality Assessment Report (Pacific Environment 2016);
- Conceptual Hydrogeological Assessment (Global Groundwater 2016); and
- Surface Water Assessment Report (JDA 2016).

Document	RWMP		Division	ENV	Status	o	Issued	
Number			Author	LJ	Review Date		Version	

1.6 Relevant Legislation

Assessment of environmental legislation relevant to the Project highlighted a number of approvals required prior to commencement of proposed activities. Legislation relevant to one or more phases of the Project includes:

- *Aboriginal Heritage Act 1972*;
- *Contaminated Sites Act 2003*;
- *Dangerous Goods Safety Act 2004*;
- *Environment Protection and Biodiversity Conservation Act 1999* (EPBC Act);
- *Health Act 1911*;
- *Mines Safety and Inspection Act 1994*;
- *Radiation Safety Act 1975*;
- *Rights in Water and Irrigation Act 1914*; and
- *Wildlife Conservation Act 1950* (WC Act).

Document	RWMP		Division	ENV	Status	o	Issued	
Number			Author	LJ	Review Date		Version	

2 Background

2.1 Processes generating waste

2.1.1 Mining

Open cut pits will be operated as blast and haul. Waste rock landforms will be constructed next to each respective pit. Radiation levels are low (averaging 0.3 – 0.9 Bq/g) in waste rock and are not classified as radioactive material using the 1 Bq/g value adopted by ARPANSA (2014) (Radiation Professionals 2016b). This material is also relatively inert geochemically, being classified as Non-acid Forming (NAF) and with low metal and metalloid concentrations (Trajectory and Campbell and Associates 2016).

2.1.2 Processing

An on-site beneficiation plant would treat up to 1 million tonnes per annum (tpa) of mineralised monazite ore. Approximately 30,000 tpa of mineral concentrate would be produced and then further processed via a hydrometallurgical process. Approximately 12,000 tpa of rare earth oxide (REO) concentrate (product) would result from the process plant. The REO concentrate will be stored in secure containment in the preparation for transport to port.

The beneficiation process would involve crushing and grinding, and flotation of the ore. The majority of tailings (waste product) will be generated during this stage, and be sent to Tailings Storage Facility 1 (TSF1) (approx. 930,000 tpa). Regrinding and flotation of the ore will then generate additional tailings and a clean concentrate. A thickener will be added to tailings before being sent to TSF2 (approx. 37,000 tpa). Following thickening and filtering, the concentrate will then be sent to the hydrometallurgical plant.

The hydrometallurgical plant will involve sulphation bake in a kiln, and then water leach to liberate and leach the rare earths into solution. The acidic solution is then neutralised with a magnesium oxide, the residue of which is filtered and separated from the solution. The residue is further treated prior to disposal in TSF3 (approx. 56,000 tpa). The leach liquor will then be purified to remove any impurities present prior to precipitation of the REO concentrate. The effluent (approx. 480 000 m³/annum) from the precipitation stage is directed to the evaporation pond.

2.2 Description of waste

2.2.1 Nature of material (chemical, physical and radiological)

Tailings from a bench-scale process have been generated as a component of metallurgical testing. Preliminary characterisation analysis of the bench-scale tailings samples has provided a reasonable

Document	RWMP		Division	ENV	Status	o	Issued	
Number			Author	LJ	Review Date		Version	

indication of the general classifications of the tailings. Trajectory (2016) summarises the outcomes from characterisation studies as follows:

TSF 1 is expected to be benign geochemically (i.e. non-acid forming (NAF)) with slight enrichments of metals in both the tailings solids and contact waters that were analysed. TSF 1 tailings will have radionuclide readings below the probable relevant thresholds (< 1Bq/g) (Radiation Professionals 2016a).

TSF 2 is expected to be benign geochemically (NAF) with slight to moderate enrichments of metals in both the tailings solids and contact waters. TSF 2 tailings will have radionuclide levels that exceed probable relevant thresholds (~7 Bq/g; Radiation Professionals 2016a). Radionuclides will not be water soluble in these tailings.

TSF 3 tailings-solids are also expected to be NAF, though strongly gypsiferous (Total-S ca. 10 %), due to neutralisation of the acidic raffinate with calcite. The tailings may be slow / difficult to drain and consolidate to a trafficable surface. Radionuclide levels are in excess of expected thresholds (~24 Bq/g; Radiation Professionals 2016a) and are water soluble due to the ‘cracking’ of the chemicals during the sulphation bake treatment in the hydrometallurgy process.

Further detailed information can be obtained in Trajectory (2016). The next stage of waste characterisation studies will occur when more representative tailings samples are produced from a pilot plant.

2.2.2 Contaminants

Elevated radionuclide concentrations in TSF 2 and 3 are the only contaminants that will trigger consideration under the *Contaminated Sites Act 2003* (WA).

2.2.3 Quantities and rate of production

Three separate tailings streams will be produced from the processing plant, disposed of in distinct TSFs. The design specification for each TSF will differ due to varying chemical and radionuclide composition. Chemical and physical characteristics, source and disposal location of each tailings stream is summarised in Table 1. Over the life-of-mine, approximately 7.2 million tonnes of tailings will be produced. Less than 9% of tailings will be considered radioactive.

Table 1 Source, Disposal and General Characteristics of Tailings Streams

Processing source	Tailings mass (%)	Annual rate (tpa)	Physical processing	Chemical properties	Radionuclide concentration	Disposal
Beneficiation	95.5%					
1. Rougher circuit	91%	932,100	Crushed and milled ore, flotation	Trace flotation reagents;	<1 Bq/g	TSF 1

Document	RWMP		Division	ENV	Status	o	Issued	
Number			Author	LJ	Review Date		Version	

Processing source	Tailings mass (%)	Annual rate (tpa)	Physical processing	Chemical properties	Radionuclide concentration	Disposal
				pH 10-11.5	(head of chain)	
2. Cleaner circuit	4.5%	37,200	Crushed and milled ore, flotation	Trace flotation reagents; pH 10-11.5	~ 7 Bq/g (head of chain)	TSF 2
Hydrometallurgical	5.5%	56,000	Acid Heating Water leach Neutralisation and waste removal Thickening	Trace sulphuric acid; U and Th; Iron phosphates Aluminium; Gypsum Metal hydroxides; pH 7-8	~24 Bq/g (head of chain)	TSF 3
TOTAL	100%	1,025,300				

2.3 Description of environment

A summary of the following environmental values at the Project site are described in Appendix A:

- Climate
- Terrain
- Vegetation
- Hydrology

2.4 Baseline radiological characteristics

Environmental monitoring programs have been implemented to coincide with ongoing occupational monitoring programs during exploration programs (Radiation Professional 2016b). Surveys have been completed over areas that are significant to the operation, prior to any disturbance of local conditions (Radiation Professional 2016b).

The baseline data includes:

- Gamma radiation.
- Radionuclides in dust.
- Radon and thoron concentrations.

Document	RWMP		Division	ENV	Status	o	Issued	
Number			Author	LJ	Review Date		Version	

- Radionuclides in soil.
- Radionuclides in water (surface and groundwater).

This Baseline Radiation Report (Radiation Professionals 2016b) is based on data collected in monitoring programs that have been running for at least 12 months. Monitoring on site is ongoing. Data is also available in the Yangibana Rare Earths Project Annual Radiation Reports.

2.4.1 Gamma radiation

Baseline gamma radiation levels have been determined via three methods; handheld instrument gamma surveys, integrating monitors and interpretation of an aerial radiometric survey (Radiation Professionals 2016b).

The monitoring shows that gamma radiation levels are elevated above mineralisation as expected, which is associated with the outcropping ironstone. Radiation Professionals (2016b) reported average gamma radiation dose rates are 0.23 $\mu\text{Gy}\cdot\text{h}^{-1}$ in areas away from the outcropping mineralization. Average gamma radiation dose rates are 0.37 $\mu\text{Gy}\cdot\text{h}^{-1}$ over the deposit areas and range up to 1.26 $\mu\text{Gy}\cdot\text{h}^{-1}$.

2.4.2 Radionuclides in dust

Baseline environmental dust sampling was conducted across the project area, from 2015 onwards, using low volume pumps (SKC AirLite and SKC Airchek 52) to collect samples over a period of at least four hours (Radiation Professionals 2016b). Airborne alpha activity concentrations are similar for all areas of the project, both over the prospects and in areas away from radiologically enhanced mineralization (Radiation Professionals 2016b). The average airborne activity on and off the deposit was 0.01 and 0.009 $\text{adps}\cdot\text{m}^{-3}$, respectively (Radiation Professionals 2016b).

2.4.3 Radon and thoron concentrations

Radon and thoron monitoring, commenced in 2015 using Landauer Radtrak devices, which were placed at four locations around the Project areas, with one pair measuring a background location at Gifford Creek Station Homestead, approximately 20 km south of the Project area (Radiation Professionals 2016b). Monitors were placed in pairs, one measuring radon only and the other measuring radon and thoron. Monitors were replaced at intervals determined by access to site, and exposure periods have ranged from 144 days up to 173 days.

Many of the radon-only monitors returned results below the minimum detection level (MDL). For estimation of values for radon and thoron concentrations, it was assumed that any result below the MDL is equivalent to the MDL value (Radiation Professionals 2016b). Radon and thoron results are presented in Table 2.

Document	RWMP		Division	ENV	Status	o	Issued	
Number			Author	LJ	Review Date		Version	

In addition to passive monitoring, real time monitoring was conducted using a portable radon detector (DurrIDGE RAD7, 2010; see Radiation Professionals 2016b)).

Table 2 Radon and thoron levels (Radiation Professionals 2016b)

Location	Average Radon (Bq.m ⁻³)	Average Thoron (Bq.m ⁻³)
Bald Hill	9.9	24.6
Fraser's	9.9	29.1
Yangibana North	10.4	16.9
Gifford Creek H.S	9.1	15.5

2.4.4 Radionuclides in soil

Both subsurface and topsoil samples were collected and analysed for uranium and thorium (Radiation Professionals 2016b).

Subsurface samples were taken from eight drill holes below the surface, within or immediately adjacent to mineralisation and were selected to be approximately representative of the Project target resource material. Samples were analysed for total uranium and thorium, and by gamma spectroscopy (ESR) for members of each decay chain (Radiation Professionals 2016b).

Analysis shows that concentrations of uranium and thorium in mineral samples vary widely. Comparison with the wider data set indicated that higher concentrations of radionuclides are found with the target rare earths oxides in mineralised areas compared to surrounding granites and metamorphics (Radiation Professionals 2016b).

A single topsoil sample was taken from a location in the Gossan prospect area of the Project site (Table 3).

Table 3 Concentration of radionuclides in a single topsoil sample (Radiation Professionals 2016b)

ID	Elemental Analysis		Potassium Mass		Radionuclide Analysis			
	U (mg.kg ⁻¹)	Th (mg.kg ⁻¹)	K (Bq.kg ⁻¹)	K (Mass %)	Ra ²²⁶ (Bq.kg ⁻¹)	Ra ²²⁸ (Bq.kg ⁻¹)	Pb ²¹⁰ (Bq.kg ⁻¹)	Th ²²⁸ (Bq.kg ⁻¹)
RP1163 / CS002	0.368	7.87	1080 ± 120	3.49 ± 0.40	16.9 ± 1.4	36.5 ± 2.7	30.3 ± 5.1	38.6 ± 4.1

Document	RWMP		Division	ENV	Status	o	Issued	
Number			Author	LJ	Review Date		Version	

2.4.5 Radionuclides in water (surface and groundwater)

2.4.5.1 Groundwater

Water sampling and analysis was conducted by ATC Williams in 2015 and Hastings in 2016 at a number of existing bores within the pit footprints of the Project, within approximately 5 km of the Project and the surrounding region. Available data outputs from both ATC Williams and Hastings' commissioned analysis show a high level of regional and local variation ranging from 0.004 to 0.038 mg/L and <0.001 mg/L of uranium and thorium levels, respectively.

A sample was collected by Radiation Professionals (2016b) from an exploration hole within the Yangibana West prospect in mid-2015 for analysis by gamma spectroscopy to determine concentrations of soluble radionuclides (Table 4).

Table 4 Concentrations of soluble radionuclides from Yangibana West pit footprint

Sample ID	Ra ₂₂₆ (Bq.kg ⁻¹)	Ra ₂₂₈ (Bq.kg ⁻¹)	Pb ₂₁₀ (Bq.kg ⁻¹)
YW-RC0003A	0.0308 ± 0.0077	0.046 ± 0.019	<0.080

2.4.5.2 Surface water

In October 2016, Hastings collected water samples from two ephemeral pools (LC - Pool 800US and FR – Pool) on the Lyons River, which only flows after heavy rainfall events. The pools are located approximately 5-10 km from the proposed processing plant area. Results are presented in Table 4.

Table 5 Uranium and thorium concentration in Lyons River and Frasers Creek ephemeral pools

Location	Total uranium (mg.L ⁻¹)	Total thorium (mg.L ⁻¹)
LC-Pool 800US	0.004	<0.001
FR - Pool	0.001	<0.001

Document	RWMP		Division	ENV	Status	o	Issued	
Number			Author	LJ	Review Date		Version	

2.5 Heritage

2.5.1 Aboriginal

Consultation with Yamatji Marlpa Aboriginal Corporation (YMAC) and Kulyumba Aboriginal Corporation has been undertaken to identify relevant Traditional Owner groups. Recently the combined Tiin-Mah Warriyangka, Tharrkari, Jiwarli submitted a native title claim (WC2016/003) (WAD464/2016) over the Project area and beyond. This means that Mining Agreements will be formally negotiated and implemented. Hastings is building a good relationship with the Traditional Owners, and will formally negotiate the necessary agreements.

A search of the Aboriginal Heritage Inquiry System on the DAA website on the 8th of March, 2016 reported no previously recorded Aboriginal heritage sites or other places within the Project area (Brad Goode and Associates, 2016). There are 4 sites within a 45km radius of the Project area, however these will not be impacted by the Project. One of these sites, the Thalaangkaya corroboree site (MGA co-ordinates 420 224.79mE 7 346 593.17mN) is located 800 m from the proposed accommodation facilities (Brad Goode and Associates, 2016).

During heritage surveys, several sites were found within or adjacent to Project areas (Brad Goode and Associates, 2016). The Combined Thiin-Mah Warriyangka, Tharrkari, Jiwarli WC2016/003 Native Title Claim group representatives' requests that:

- A 150m exclusion buffer zone is placed on either side of all natural waterways;
- Native vegetation clearing is to be kept to a minimum; and
- The Traditional Owners be re-consulted when the location of the proposed tailings storage facilities have been finalized, and that the TSFs be actively managed in order to ensure that they do not contaminate or pollute any natural waterways (Brad Goode and Associates, 2016).

2.5.2 European

The existence of European heritage values within the Yangibana Project area has been investigated through the Australian Heritage Commission and Heritage Council of Western Australia databases. No sites of European heritage were identified within or immediately adjacent to the mine activities envelope.

Two European heritage sites were located within the region of the Yangibana tenements - Cobra Station (formerly Bangemall Hotel), Place 04129 and the old Cobra Station, Place 15419. Both are listed on the Western Australian heritage register.

Document	RWMP		Division	ENV	Status	o	Issued	
Number			Author	LJ	Review Date		Version	

2.6 Land use (present and potential)

The predominant land use in the area is pastoralism with limited tourism.

Historically the Gascoyne Bioregion has been used extensively for pastoralism i.e. grazing of sheep, goats and cattle on pastoral stations (Ecoscape 2016c). Currently, pastoralists only graze cattle due to feral dogs significantly reducing sheep and goat numbers. Ecoscape (2016c) quotes the *Rangelands-Taking the Pulse Report* (Department of the Environment 2008), which describes the Gascoyne bioregion as being grazed at between 70-80% from 1992 to 2005.

Wanna, Edmund and Gifford Stations occur in the near vicinity of the project, with Wanna Station being the closest at approximately 10 km from the TSFs. Pastoral bores are located within the shallow calcretes along the Lyons River and Frasers Creek. The nearest pastoral bore is situated approximately 2 km from the TSFs.

Gascoyne Junction is the nearest town (population of approximately 250), and occurs downstream at the junction of the Lyons River and Gascoyne River, approximately 150 km from the Project area. This town is a centre for mining, tourism and pastoralism.

Document	RWMP		Division	ENV	Status	o	Issued	
Number			Author	LJ	Review Date		Version	

3 Management

3.1 Risk Assessment

A risk based approach has been used to identify hazards, unwanted events and risks associated with the processing and disposal of radioactive waste. A risk assessment, based on the *Leading Practice Sustainable Development Program for the Mining Industry - Risk Assessment and Management* (Department of Resources, Energy and Tourism (DRET) 2008), is a component of the Hastings EMS (*Risk Procedure*). The risk assessment is applicable to the all phases of the Project, including the Definitive Feasibility Study (DFS). The risk assessment and associated register is a living process and will be updated during subsequent phases of the Project and then annually following commencement of operations (unless change management or major incidents dictate that it should be sooner):

- Detailed Engineering phase;
- Construction phase; and
- Operations phase.

Nearest sensitive environmental receptors include:

- Lyons River and Frasers Creek (significant cultural heritage values, and associated aquifers downstream from the TSFs);
- Pastoral bores (closest one is 2 – 3 km from TSF 2 and 3); and
- Employees at the Project site.

The risks associated with the radioactive waste, namely tailings to be deposited in TSF 2 and 3, include:

- Seepage of leachable heavy metals and contaminants;
- Dust generation at ROM pad, processing plant and TSFs;
- Contaminated surface water; and
- Long-term TSF integrity following decommissioning and closure.

The risks associated with radioactive waste are also applicable to other contaminants in the tailings materials. The following describes mitigation actions to be implemented.

Document	RWMP		Division	ENV	Status	o	Issued	
Number			Author	LJ	Review Date		Version	

3.2 Mitigation of Risk

3.2.1 Design criteria

Design and engineering of TSF 2 and 3 will be a critical component of the Definitive Feasibility Study and Detailed Design phases of the Project.

Studies that have been or will be completed to inform the TSF design include, but not limited to:

- Climate
- Physical and geochemical assessment of tailings and waste rock
- Surrounding environmental, heritage and social values
- Surface water and groundwater assessment
- Water inputs and outputs i.e. water balance
- Water quality
- Description of the process
- A geotechnical assessment

Design features of TSFs taking into consideration the concentration of radionuclides is summarized in Table 4.

Table 6 Proposed TSF Design Features

Design feature	TSF1	TSF2	TSF3
Proportion of process tailings	91%	4%	5%
Radionuclide concentrations	< 1 Bq/g	~ 7 Bq/g	~ 24 Bq/g
Maximum height (m)	Perimeter embankments – 6 m Tailings stack – 15 m	Perimeter embankments – 6 m	Perimeter embankments – 6 m
Area (ha)	100 ha	7 ha	11 ha
Number of cells	1	1	1
Construction	Downstream perimeter embankment raising	Downstream perimeter embankment raising	Downstream perimeter embankment raising
Discharge method	Single point Central Thickened Discharge (CTD)	Perimeter spigots	Perimeter spigots
Lining	Proof compacted basal clayey sand layer	HDPE / other + compacted clayey sand	HDPE / other + compacted clayey sand

Document	RWMP		Division	ENV	Status	o	Issued	
Number			Author	LJ	Review Date		Version	

Design feature	TSF1	TSF2	TSF3
Encapsulation	Nominal capillary break/erosion protection + topsoil	HDPE/ compacted clayey sand base. HDPE/CCL engineered capping with waste rock cover and topsoil. Design in accordance with IAEA safety standards to provide safe containment of LLW / NORM radionuclides for periods beyond the extent of institutional control.	HDPE/ compacted clayey sand base. HDPE/CCL engineered capping with waste rock cover and topsoil. Design in accordance with IAEA safety standards (WS-G-6.1) to provide safe containment of LLW / NORM radionuclides for periods beyond the extent of institutional control. Leak detection.
Leak detection	Downstream groundwater monitoring holes	Downstream groundwater monitoring holes	Downstream groundwater monitoring holes + underdrain between the clay layer and the HDPE with sump

The site will be designed to retain surface water runoff around the ROM, processing plant and TSF 2 and 3 from a significant storm event.

Third party review will occur in accordance with industry best practice and recommendations by ANCOLD (2012). Ensuring the construction and operation of the TSFs occur in accordance with the design and engineering criteria will also be critical, while monitoring and review of the performance of each TSF will occur as described in Sections 5 and 8, respectively.

Design of the TSFs will be guided by the following documents:

- *Code of Practice for Radiation Protection and Radioactive Waste Management in Mining and Mineral Processing* (ARPANSA 2005) (the Mining Code);
- *Managing naturally occurring radioactive material (NORM) in mining and mineral processing guideline. NORM 4.2. Management of radioactive waste* (DMP 2010) (NORM Guideline 4.2);
- *Code of Practice – Tailings Storage Facilities in Western Australia* (DMP, 2013);
- *Guide to the Preparation of a Design Report for Tailings Storage Facilities* (DMP, 2015);
- *Guidelines on the Safe Design and Operating Standards for Tailings Storage* (DMP 2013, prev. DME);
- *Guidelines on the Development of an Operating Manual for Tailings Storage* (DMP, 1998; prev. DME);
- *Guidelines on Tailings Dams - Planning, Design, Construction, Operation and Closure* (ANCOLD, 2012);
- *Guidelines on the Consequence Categories for Dams* (ANCOLD, 2012);

Document	RWMP		Division	ENV	Status	o	Issued	
Number			Author	LJ	Review Date		Version	

- *Storage of Radioactive Waste: Safety Guide (IAEA, 2006)*; and
- *Tailings Management: Handbook in the Leading Practice Sustainable Development Program for the Mining Industry Series* (Australian Government Department of Industry, Tourism and Resources, 2007).

Following TSF design, a TSF operating manual will be developed and include the following minimum requirements as set out by the DME (1998; now DMP):

- Objectives of the Operating Manual;
- Project background;
- Life of mine and life of TSFs;
- Figure indicating general location of TSFs;
- Drawing showing general arrangement of TSFs;
- Hazard rating;
- General description of mineral processing and tailings storage;
- Timelines (i.e. construction, operations, closure);
- All pertinent information with respect to operation, rehabilitation and closure of the TSFs including:
 - Deposition methodology;
 - Water management;
 - Seepage control (including drain details and requirements)
 - Pipeline management;
 - All measures that should be followed during the operating phase to reduce the amount of work required at decommissioning;
 - Planned measures to reduce impact(s) to the surrounding environment;
 - Planned measures for progressive rehabilitation during operations.

3.2.2 Construction and operations

The as-built geometry should comply with the design geometry as closely as possible, and any discrepancies will be recorded in the Operating Manual, together with a certification by the designer that the safety of the TSF has not been compromised (DME 1998). The phreatic surface will be measured during the life of the TSF to ensure that the design assumptions are reasonable and that any deviations will not pose a threat to the stability of the wall. The Operating Manual will include limits of the expected variation in piezometric levels. Actions to be taken in the event that actual values or measurements exceed those expected will be detailed in the Operating Manual. The instruments should be read on a monthly basis as a minimum requirement, and more frequently if the piezometric levels are approaching the anticipated maximum levels.

Document	RWMP		Division	ENV	Status	o	Issued	
Number			Author	LJ	Review Date		Version	

The Operating Manual will contain details of any underdrainage that is installed in the TSF, including:

- Drawings showing details of filter drains;
- A plan showing the location and reference numbers of underdrain outfall pipes;
- A plan showing the location and reference numbers of any dewatering bores;
- The expected flows or rest water levels associated with the drainage systems; and
- A procedure for action in the event of flows or levels falling outside the expected values.

The following management measures for pipelines shall be considered in the TSF Operating Manual:

- Periodic rotation of steel pipelines (flanges to be date stamped for reference);
- Pipe wall thickness checking (steel pipes);
- Preventative maintenance through a periodic replacement policy;
- Regular pipeline inspections;
- Automatic shut-off valves linked to pressure transducers located on the pipelines;
- Bunds on either side of pipelines;
- Periodic clearing of vegetation under and around the pipelines to prevent damage from bush fires.

Generation of, and exposure to, dust will be controlled through standard dust management procedures including:

- All mining vehicles would be fitted with air conditioners and air filters;
- Ensuring wet processes are used and where this is not possible, ensuring that adequate watering occurs to significantly reduce dust generation on roads and in the processing plant;
- Covering and/or misting on conveyor belts, where used;
- Spillage management and control;
- Watering of roads and ore stockpiles;
- Maintaining 'wet' tailings in TSF 2 and 3; and
- Progressive covering of drying tailings during decommissioning, where possible.

Water that has come in contact with radioactive waste, such as storm water runoff from the processing plant or direct rainfall on to TSFs will be managed on-site. The evaporation pond, and appropriate collection bunds and channels will be used to manage potentially contaminated surface water runoff.

Waste water collected from the site including wash down areas and clean-up water would be either reused in the processing plant or directed to the evaporation pond.

Document	RWMP		Division	ENV	Status	o	Issued	
Number			Author	LJ	Review Date		Version	

Requirements and constraints to be considered¹, specific to the current state of knowledge, and relevant to the Project, include:

- Solubility of thorium is very sensitive to pH at around 4. The pH of tailings in TSF 2 and 3 range from 10-11.5 and 7-8, respectively. This will reduce the concentration of thorium in water (NORM Guideline 4.2; DMP, 2010). Any changes to the process that may result in a change to the chemistry of the tailings will need to assess the implications to pH and solubility of thorium.
- Modelling is required to design a cover, which will be effective for the TSF location (with consideration of climate regime, net water balance in the area, and the reactivity of the tailings material) (NORM Guideline 4.2; DMP, 2010). The cover depth will be optimized taking into account radon emissions.
- Encapsulation of radioactive tailings waste (TSF 2 and 3) with impervious cover materials.
- Drainage and water management pre- and post-closure.
- The maintenance of an adequate freeboard on each TSF. The freeboard will need to be sufficient to contain unforeseen increases in the level and movement of fluid within the storage caused by the following:
 - Tailings spills or overflow from spigot malfunctioning.
 - Back flow and overtopping as a result of mounding of tailings at discharge points.
 - Outlet and/or recovery system failures.
 - Uncertainties in the design rainfall estimates.
 - Uncertainties in the design catchment and runoff estimates.
 - Extreme wind effects.
 - Seismic events.
- Maintaining ‘wet’ tailings in TSF 2 and 3 during operations to reduce dust generation.
- Design criteria to consider integrity of TSFs post-closure.
- Planning for closure.

3.2.3 Decommissioning and Closure

A Mine Closure Plan (MCP) will be developed in accordance with the *Guidelines for Preparing Mine Closure Plans* (DMP/EPA, 2015). Planning for decommissioning and closure of the TSFs will occur during all phases of the Project based on:

- Research outcomes

¹ Continuing consultation between the operator and the relevant regulatory authority (i.e. DMP, Radiological Council, DER) is required to ensure an optimum design of TSFs will be achieved to meet the requirements for radiation protection and waste management (the Mining Code; ARPANSA, 2005). Consultation will allow all parties to be clear on the requirements and constraints that should be considered (the Mining Code; ARPANSA, 2005).

Document	RWMP		Division	ENV	Status	o	Issued	
Number			Author	LJ	Review Date		Version	

- Environmental performance of the TSFs during operations
- Progressive rehabilitation outcomes
- Monitoring results
- Annual review of the risk register against performance indicators
- Lessons learned from environmental performance of other TSF designs and management measures in the mining industry.

3.2.3.1 Decommissioning

The MCP has a whole-of-site approach to decommissioning activities. In addition to the MCP, a Decommissioning Plan must be approved by the DMP Resources Safety Branch and the Radiological Council prior to any site closure activities commencing. The disposal of contaminated plant and equipment will be the focus during the decommissioning phase.

An inventory will be developed and an assessment of contamination will be conducted for all plant and equipment. Where recycling or reuse of plant or equipment is feasible, items will be decontaminated to radiation levels less than 1Bq/g before leaving site. An appropriate disposal method will then be determined for each plant and equipment, identified as waste, based on level of contamination.

TSF 2 and 3, as well as the Evaporation Pond will be drying during the decommissioning phase. Cover materials will need to allow drying to take place without generating excessive dust while the drying occurs from the outside of the facilities in the first instance.

3.2.3.2 Closure

The closure activities of the mine site are described in detail within the MCP. Specific to radiation, the TSFs will be capped, covered with overburden and rehabilitated. Following rehabilitation, no alpha-emitting dust or radioactive gas emanations will occur above that of background levels.

Radioactive material that is mobile (TSF 3) and picked up via water flows will be captured by an underdrain between the clay layer and the HDPE and retained by a sump.

Gamma emissions will be within background levels reducing the threat to members of the public.

The Department of Environment Regulation (DER) will be notified of all landforms containing radioactive waste material, as required under the *Contaminated Sites Act 2003*. If land use is restricted due to radioactivity levels, covenants on land use will be applied through the *Contaminated Sites Act 2003* and exclusions zones put in place by DER and/or Radiological Council.

An assessment of final void water quality will be undertaken to determine if management of the pit lakes is required, and determine potential impacts to any fractured rock aquifers associated with the target ore body.

Document	RWMP		Division	ENV	Status	o	Issued	
Number			Author	LJ	Review Date		Version	

Further closure considerations for TSF 2 and 3 are detailed in Appendix B.

Document	RWMP		Division	ENV	Status	0	Issued	
Number			Author	LJ	Review Date		Version	

4 Monitoring

4.1 Pre-operational monitoring

A pre-operational monitoring program has been undertaken during the exploration phase (2015 -on-going) taking into account *NORM Guideline 3.1. Monitoring NORM – pre-operational guideline* (DMP, 2010b) and provided in the Baseline Radiation Report (Radiation Professionals 2016b). The results to-date are interpreted by Radiation Professionals (2016a and 2016b) and summarised in Section 3.3.6.

Monitoring of the construction process to ensure the TSFs are built in accordance with design specifications will occur during the construction phase. A TSF construction management plan with quality assurance procedures will be developed and implemented to ensure that the TSF construction meets design specifications and tolerances. A competent person will be engaged to certify that the construction of the TSF meets design specifications and tolerances (as specified in DMP, 2013). The competent person will produce a report, which will include:

- conditions encountered during construction (including field and laboratory testing) and verify them against assumptions of each TSF design;
- a non-compliance report with documented remedial measures if the conditions encountered did not meet the original design assumptions or specifications;
- a variance report if the construction was required to deviate from the original design;
- a demonstration that the testing and measurement regime was appropriate and sufficient to validate the design parameters; and
- survey drawings of each TSF showing the true positions of features such as borrow pits, embankments, drains, topsoil stockpiles, capping material sources, process water and return water ponds, seepage trenches, monitoring instrumentation, and buried pipework and cables.

4.2 Operational monitoring

During operations, an environmental radiation monitoring program will be developed taking into account *NORM Guideline 3.2. Monitoring NORM – operational monitoring requirements* (DMP, 2010c). In the design of the monitoring program, the following elements are or will be considered:

- A change in the physical and chemical characteristics of radionuclides due to the hydrometallurgical process. TSF 3 contains mobilised radionuclides at concentrations of approximately 24 Bq/g.

Document	RWMP		Division	ENV	Status	o	Issued	
Number			Author	LJ	Review Date		Version	

- Possible pathways of exposure of workers includes dust generation from the processing plant and TSF 2 and 3 (note TSF 1 contains radionuclides at < 1 Bq/g). The tailings of TSF 2 and 3 will remain ‘wet’ during the operations phase.
- Possible pathways of exposure for members of the public and local environment include potential seepage into groundwater via lateral movement and surface hydrology of drainage channels, creeks and the river. TSF 2 and 3 have been designed to encapsulate and contain the tailings. Design parameters that have addressed the possible pathways of exposure will be monitored to ensure their effectiveness.
- Ensure the TSF actual performance occurs in accordance with the expected performance as described in the Mining Proposal for the Project.
- All areas on-site will be classified as supervised or controlled areas.

4.2.1 Sources

An *Environmental Radiation Monitoring Work Instruction*, a component of the Hastings EMS, will be developed to provide specific protocols for environmental radiation monitoring from the following sources:

- Direct gamma radiation: A survey of the perimeter of the Development Envelope to measure gamma radiation levels will be conducted on an annual basis.
- Radon decay products: Track etch monitors will rotate between off-site locations.
- Seepage into groundwater: A network of monitoring bores will be established down gradient from the TSFs, sampled and analysed for heavy metals including radionuclides, on a quarterly basis.
- Contamination of surface water run-off: Surface water sampling will be conducted opportunistically following significant rainfall events or on a quarterly basis.
- Contamination of potable water supply: Sampling and radiometric analysis will be conducted as detailed in the Drinking Water Quality Management Plan (to be developed and as required by the Department of Health).
- Dust containing long-lived alpha-emitting radionuclides: Dust deposition gauges and high volume samplers will collect dust samples at pre-determined locations for composite analysis on an annual basis and rotate between approved off-site locations, respectively.

NORM Guideline 6 Reporting Requirements (DMP 2010d) states that *each measurement must be undertaken using an agreed technique and appropriate monitoring equipment. Once approved these techniques do not need to be detailed in the reports. However, any changes in the techniques must be approved before being used as the basis of the reports.*

Document	RWMP		Division	ENV	Status	o	Issued	
Number			Author	LJ	Review Date		Version	

4.2.2 Containment Controls

Monitoring of controls for containment of radioactive waste will include:

- Weekly visual inspection of surface water management structures including bunds, drainage channels, tailings and water pipelines, and evaporation ponds.
- Weekly inspection of the walls of TSF 2 and 3 for erosion or other signs of potential compromise to the integrity of their structure, including signs of seepage of tailings or water from tailings into the environment immediately surrounding the TSFs.
- Inspections of management controls following major rainfall or extreme weather events.
- Annual inspection/audit by closure specialist to identify potential hazards, risks and opportunities for continual improvement, including aspects that require further investigation or research.
- Internal audits (in accordance with the EMS Audit Operating Procedure) of the implementation of this RWMP.

Monitoring of TSF 1, TSF 2 and TSF 3 performance will also be described in detail in the TSF Operating Manual (DME 1998). The operating manual will detail procedures for routine inspections of TSFs, operational audit of TSFs, groundwater monitoring, monitoring instrumentation and environmental aspects. DME (1998) specifically states:

Details pertaining to monitoring instrumentation (e.g. piezometers) should describe the method and frequency of measurement. The Operating Manual should describe the short and long term range of readings that are anticipated for all monitoring instruments, underdrain flows, open channel flows etc, throughout the life of the TSF. Actions to be followed in the event that readings are recorded outside an anticipated envelope of measurements should be stipulated in the Operating Manual.

4.2.3 Trigger values

Trigger values are based on authorised limits and/or baseline values and take account those identified in NORM Guideline 6 Reporting Requirements (DMP, 2010d) (Table 5).

Table 7 Investigation level recommended for each radiation parameter (DMP, 2010d)

Radiation Parameter	Investigation Level	Comment
<i>1. Area gamma dose rate</i>		
1.1 Site boundary	>1.1 µGy/hr above background	> 1 mSv/year for a member of the public (8760 hrs/year)
1.2 Supervised area	> 0.5 µGy/hr above background	> 1 mSv/year for an employee (2000 hrs/year)
1.3 Controlled area	> 2.50 µGy/hr above background	> 5 mSv/year for an employee (2000 hrs/year)

Document	RWMP		Division	ENV	Status	o	Issued	
Number			Author	LJ	Review Date		Version	

Radiation Parameter	Investigation Level	Comment
1.4 Restricted	> 7.50 µGy/hr above background	> 15 mSv/year for an employee (2000 hrs/year)
<i>2. Personal external dose</i>		
2.1 Designated worker	> 2.5 mSv in a quarter	> 10 mSv/year
2.2 Non-designated worker	> 0.5 mSv in a quarter	> 2 mSv/year
<i>3. Personal internal dose</i>		
3.1 Designated worker	> 5.0 mSv in a quarter	Assessed from air sampling
<i>4. Airborne radioactivity</i>		
4.1 Total alpha activity on the personal air sample – U dust	> 9.9 Bq/m ³ for 12-hr shift sample	~ 0.5 mSv/shift
4.2 Total alpha activity on the personal air sample – Th dust	> 4.3 Bq/m ³ for shift sample	~ 0.5 mSv/shift
4.3 Total alpha activity on the personal air sample – U dust	4 consecutive samples > 2.4 Bq/m ³	Indicates potential for significant exposure
4.4 Total alpha activity on the personal air sample – Th dust	4 consecutive samples > 1.0 Bq/m ³	Indicates potential for significant exposure
4.5 Total alpha activity	> Mean + 3 standard deviations	Indicates potentially unusual working conditions
4.6 Total alpha activity on environmental air sample – U dust	> 2 mBq/m ³ on high volume air sampler	> 100 µSv/year for a member of the public continuously exposed (> 10% of exposure limit)
4.7 Total alpha activity on environmental air sample – Th dust	> 1 mBq/m ³ on high volume air sampler	> 100 µSv/year for a member of the public continuously exposed (> 10% of exposure limit)
<i>5. Airborne dust</i>		
5.1 Inhalable dust on personal air sample	> 10 mg/m ³	Statutory limit for respirable dust concentration
5.2 Respirable dust on personal air sample	> 3 mg/m ³	Statutory limit for respirable dust concentration
<i>6. Radon/Thoron in air</i>		
6.1 Radon (²²² Rn) in air - workplaces	> 3.5 mJh/m ³	> 5 mSv/year for an employee (2000 hrs/year)
6.2 Thoron (²²⁰ Rn) in air - workplaces	> 10.7 mJh/m ³	> 5 mSv/year for an employee (2000 hrs/year)
<i>7. Radionuclides in water</i>		
7.1 ²²⁶ Ra in ground water or surface water	> 0.5 Bq/L ²²⁶ Ra or 2x average pre-operational levels for waters containing high levels of radium	100 µSv/year for ingestion of 2L/day for a year

Document	RWMP	Division	ENV	Status	o	Issued	
Number		Author	LJ	Review Date		Version	

Radiation Parameter	Investigation Level	Comment
7.2 ²²⁸ Ra in ground water or surface water	> 0.2 Bq/L ²²⁸ Ra or 2x average pre-operational levels for waters containing high levels of radium	100 µSv/year for ingestion of 2L/day for a year

Exceedances of a trigger value will be considered an incident unless significant seasonal environmental variation of background levels are expected, e.g., salinity levels in permanent ponds. In such instances, a trend of exceedances in trigger values will then be treated as an incident.

4.2.4 Quality Assurance

NORM Guideline 3.2. Monitoring NORM – operational monitoring requirements (DMP, 2010c) highlights the importance of having a quality assurance program. ARPANSA (2005) requires *that the quality assurance program which is compliant with Australian Standards should be implemented, including traceability of all radiation measurements to Australian metrological² standards where possible.*

Quality assurance is integrated throughout the Hastings EMS. Other applicable systems include a Quality Management System, and Occupational Health and Safety System. Hastings management system framework integrates the requirements of the above listed systems international standards (ISO 14001, 9001 and AS/NZS 4801 and 4804), which is currently in development and will be implemented.

4.2.4.1 Equipment

Quality assurance of equipment and instruments, including calibration and maintenance, will form a component of the *Environmental Radiation Monitoring Work Instruction*.

4.2.4.2 Sample Analysis

Hastings will only engage recognised, accredited laboratories to conduct sample analysis. Accurate records of sampling and sample analysis will be maintained using Yangibana *Field Record Form* and *Chain of Custody Form*. Use of these forms and records to be maintained will be detailed in the *Environmental Radiation Monitoring Work Instruction* and will be in accordance with Yangibana *Records Procedure*.

Control samples and the consistent use of standard methods for analysis will verify monitoring procedures detailed in the *Environmental Radiation Monitoring Work Instruction*.

² Metrology is defined by the International Bureau of Weights and Measures (BIPM) as 'the science of measurement, embracing both experimental and theoretical determinations at any level of uncertainty in any field of science and technology.'

Document	RWMP		Division	ENV	Status	o	Issued	
Number			Author	LJ	Review Date		Version	

4.2.4.3 Personnel

Hastings will employ competent, qualified and experienced environmental professionals to conduct the monitoring activities. Prospective employees will be assessed and employed based on their experience in conducting environmental monitoring.

4.2.4.4 Training

An on-going training program relevant to the RWMP will be in place in accordance with Hastings *Training Procedure*.

4.2.4.5 Audits and Inspections

An audit program in accordance with Hastings *Audit and Inspections Procedure* will assess whether or not monitoring is being undertaken against established requirements set out in this RWMP and the *Environmental Radiation Monitoring Work Instruction*.

Document	RWMP		Division	ENV	Status	o	Issued	
Number			Author	LJ	Review Date		Version	

5 Contingency Planning

Contingency planning will form a component of the risk assessment, in case pre-determined mitigation is not effective. Contingency plans will form a component of the Emergency Management Plan.

Where containment of radioactive waste fails, the Hastings *Emergency Management Plan* will include:

- Human health and safety first: response to exposure, evacuation, decontamination of the persons exposed to radiation;
- Stabilisation of the containment and prevention of impact to surrounding environmental receptors;
- Consideration of secondary containment and drainage;
- Clean-up procedures;
- Training of personnel on the Emergency Response Team to address radioactive waste containment failures;
- Identification of radiation specialists and TSF experts to review contingency plans; and
- Suspension of operations (also considered in the Care and Maintenance section of the MCP).

Document	RWMP		Division	ENV	Status	o	Issued	
Number			Author	LJ	Review Date		Version	

6 Reporting

6.1 Documentation

Reporting requirements are outlined taking into account *NORM Guideline 6 Reporting Requirements* (DMP, 2010d). The following reporting commitments (Table 3) align with the requirements of legislation or stakeholder concerns.

Table 8 Reporting Commitments

Stakeholder	Legal Requirement	Timing
DMP Environment Branch	Annual Environmental Report	Annually
DMP, DER	Incidents	At time of occurrence
DMP Resources Safety Branch	Environmental Radiation Monitoring Report for the period 1 October to 30 September. Details of the operation of the radioactive waste management system as approved in the Radiation Management Plan.	Annually (within 8 weeks from 30 Sept)
DER, public (via Hastings website)	Annual Compliance Report	Annually
DoH*	Water quality monitoring of potable water	Quarterly
DoH*	Where the estimated annual radiation dose from radionuclide analysis of radium-226 and radium-228 exceeds 0.5 mSv in potable water supply.	Within 24 hrs
Wanna Station	Monitoring results of pastoral bores	Annually or as requested
Employees	Monitoring results	Relevant to monitoring procedure

*DoH, 2013

The Environmental Radiation Monitoring Report shall be prepared by a suitably qualified professional, typically an approved radiation safety officer (RSO), signed by the RSO and counter-signed by the Registered Manager.

The statutory report shall contain, as detailed in *NORM Guideline 6 Reporting Requirements* (DMP, 2010d), for each radiation parameter listed in the radiation monitoring program, the following information:

Individual sample:

- Equipment used, calibration records, the type, number, date and time of the measurement.
- Name or another suitable identifier for a personal air sample.
- Sampling location for an area gamma radiation measurement and for a positional air sample.

Document	RWMP		Division	ENV	Status	o	Issued	
Number			Author	LJ	Review Date		Version	

A group of data:

- The range and the mean with estimates of accuracy and precision (e.g., a standard deviation).
- A suitably scaled map or plan with direction indicator.
- Indications of trends in data, preferably in a graphical form.
- Comparison of the obtained results with authorised limits and/or baseline values collected prior to the commencement of operations.
- Reference to the techniques or equipment used.

The minimum contents of the annual Environmental Radiation Monitoring Report are listed in *NORM Guideline 6 Reporting Requirements* (DMP, 2010d).

The annual environmental radiation monitoring report shall be submitted electronically with copies of all certificates of analyses obtained from off-site laboratories.

6.2 Incidents

All hazards and incidents will be reported in accordance with Hastings *Hazards and Incident Reporting Procedure*.

Document	RWMP		Division	ENV	Status	o	Issued	
Number			Author	LJ	Review Date		Version	

7 Review

Constant review, application of latest scientific knowledge and ‘lessons learnt’ from similar operations are considered. An adaptive management approach will ensure optimum performance and management of risks are applied via this RWMP document.

This RWMP will be further developed throughout each phase of the Project, and will also be reviewed whenever there is a significant change in the operation of the TSFs or process plant that may impact the engineering considerations in the TSF design and implementation of the design criteria.

Review of this RWMP will include adaptive management actions or procedures to learn from the implementation of mitigation measures, monitoring and evaluation against trigger values. The following approach will be implemented:

- Monitoring data will be evaluated and compared to baseline and reference site data following the collection of monitoring data (as outlined in Section 5). Trends will also be assessed to verify modelling or the anticipated performance of mitigation measures.
- On-going research and assessment outcomes will identify opportunities or risks, which will be considered in the context of radioactive waste management and TSF performance.
- When trigger level actions do not have the anticipated outcomes, revise mitigation measures and obtain specialist advice.
- Continue to gain an increased understanding of site-specific environmental aspects (i.e. hydrological processes, sensitive receptors).
- External changes during the life of the proposal (e.g. changes to the sensitivity of the key environmental factor, implementation of other activities in the area);
- Review of risk register against performance measures, including (but not limited to) monitoring results, company culture, personnel changes, economic conditions or changes to process plant.

Document	RWMP		Division	ENV	Status	o	Issued	
Number			Author	LJ	Review Date		Version	

8 References

- ANCOLD. 2012. *Guidelines on Tailings Dams - Planning, Design, Construction, Operation and Closure*
- ANCOLD. 2012. *Guidelines on the Consequence Categories for Dams*
- ARPANSA. 2005. *Code of Practice and Safety Guide: Radiation Protection and Radioactive Waste Management in Mining and Mineral Processing*. Radiation Protection Series Publication No.9, Australian Radiation Protection and Nuclear Safety Agency (ARPANSA).
- Australian Government Department of Industry, Tourism and Resources. 2007. *Tailings Management: Handbook in the Leading Practice Sustainable Development Program for the Mining Industry Series*.
- Bennelongia. 2016. *Yangibana Rare Earths Project Subterranean Fauna Assessment*. A report prepared by Bennelongia for Hastings Technology Metals Ltd.
- Brad Goode and Associates. 2016. *Report of an Aboriginal Heritage Survey for the Yangibana Mining Project: Upper Gascoyne Region, Western Australia*. A report prepared by Brad Goode and Associates for Hastings Technology Metals Ltd.
- DME. 1998. *Guidelines on the Development of an Operating Manual for Tailings Storage*.
- DMP. 2010a. *Managing naturally occurring radioactive material (NORM) in mining and mineral processing guideline. NORM 4.2. Management of radioactive waste*.
- DMP. 2010b. *Managing naturally occurring radioactive material (NORM) in mining and mineral processing guideline. NORM 3.1. Monitoring NORM – pre-operational guideline*.
- DMP. 2010c. *Managing naturally occurring radioactive material (NORM) in mining and mineral processing guideline. NORM 3.2. Monitoring NORM – operational monitoring requirements*.
- DMP. 2010d. *Managing naturally occurring radioactive material (NORM) in mining and mineral processing guideline. NORM 6. Reporting Requirements*.
- DMP. 2013. *Guidelines on the Safe Design and Operating Standards for Tailings Storage*.
- DMP. 2013. *Code of Practice – Tailings Storage Facilities in Western Australia*.
- DMP. 2015. *Guide to the Preparation of a Design Report for Tailings Storage Facilities*.
- DMP/EPA. 2015. *Guideline for Preparing Mine Closure Plan*.
- DoH. 2013. *System compliance and routine reporting requirements for small community water providers*. Environmental Health Directorate, Department of Health, Western Australia.

Document	RWMP		Division	ENV	Status	o	Issued	
Number			Author	LJ	Review Date		Version	

Ecoscape. 2016. *Yangibana Mine Closure Plan*. A report prepared by Ecoscape for Hastings Technology Metals Ltd.

Ecoscape. 2016a. *Yangibana Rare Earths Project Vegetation and Flora Assessment Report*. A report prepared by Ecoscape for Hastings Technology Metals Ltd.

Ecoscape. 2016b. *Yangibana Rare Earths Project Subterranean Fauna Assessment*. A report prepared by Ecoscape for Hastings Technology Metals Ltd.

Global Groundwater. 2016. *Yangibana Rare Earths Project Conceptual Hydrogeological Assessment*. A report prepared by Global Groundwater for Hastings Technology Metals Ltd.

Hastings Technology Metals Ltd. 2016. *Construction Radiation Management Plan*. A management plan prepared by Dean Crouch for Hastings Technology Metals Ltd.

Hastings Technology Metals Ltd. 2016. *Operations Radiation Management Plan*. A management plan prepared by Dean Crouch for Hastings Technology Metals Ltd.

Hastings Technology Metals Ltd. 2016. *Cultural Heritage Management Plan*.

IAEA 2006. *Storage of Radioactive Waste: Safety Guide*. No. WS-G-06. Vienna: International Atomic Energy Agency (IAEA).

JDA and Associates. 2016. *Yangibana Rare Earths Project Surface Water Assessment*. A report prepared by JDA and Associates for Hastings Technology Metals Ltd.

Landloch 2016a. *Yangibana Rare Earths Project Soils Assessment*. A report prepared by Landloch for Hastings Technology Metals Ltd.

Landloch. 2016b. *Yangibana Rare Earths Project Waste Rock Characterisation Assessment*. A report prepared by Landloch for Hastings Technology Metals Ltd.

Pacific Environment. 2016. *Yangibana Rare Earths Project Air Quality Assessment Report*. A report prepared by Pacific Environment for Hastings Technology Metals Ltd.

Radiation Professionals. 2016a. *Yangibana Rare Earths Project Baseline Radiation Report*. A report prepared by Radiation Professionals for Hastings Technology Metals Ltd.

Radiation Professionals. 2016b. *Yangibana Rare Earths Project Radiation Characterisation Report*. A report prepared by Radiation Professionals for Hastings Technology Metals Ltd.

Trajectory, and Graham Campbell and Associates. 2016. *Yangibana Rare Earths Project Waste Rock and Preliminary Tailings Characterisation Report*. A report prepared by Trajectory, and Graham Campbell and Associates for Hastings Technology Metals Ltd.

Document	RWMP		Division	ENV	Status	o	Issued	
Number			Author	LJ	Review Date		Version	

9 Appendices

Appendix A: Technical Note - Summary of Environment

Document	RWMP		Division	ENV	Status	o	Issued	
Number			Author	LJ	Review Date		Version	

Document	RWMP		Division	ENV	Status	0	Issued	
Number			Author	LJ	Review Date		Version	