



BEENUP WIND FARM

OSOM Route Study

Date: April 2024
Client: [REDACTED]
SynergyRED
Type: Physical Survey
Rev: 1

Table of Contents

- 01 Overview 7**
 - 01.1 Scope of Survey 8
 - 01.2 Port of Import..... 8
 - 01.3 Site 8
 - 01.4 Cargo Dimensions10
 - 01.5 Equipment10
 - 01.6 Equipment Schematic12
 - 01.7 Blade Trailer Turning Circle14
 - 01.8 Port Operations at Bunbury16
- 02 Route 1 - Bunbury to Beenup WF 19**
 - 02.1 Route Overview20
- 03 Site Entrance Assessment 43**
- 04 Conclusion 55**
 - 04.1 Summary56
 - 04.2 Summary of Road Modifications58

Revision History

Revision	Date	Details	Prepared	Checked	Approved
0	03/04/2024	First issue	■	■	JJM
1	04/04/2024	Updated swept paths to avoid tree clearing	■	■	JJM

Disclaimer

This report has been prepared for advisory purposes only. Information provided within the report is based on data provided by the Client as well as publicly available information and, to the best of ARES Project Services Pty Ltd's knowledge and experience, is accurate at the time of publication. All proposed routes, methodologies and schedules described in this report are subject to approval and issue of permits from the relevant stakeholders. Transport equipment is based on ARES Project Services Pty Ltd vehicles and trailers, and swept path analysis results may differ if using equipment by third parties.

ARES Project Services Pty Ltd accepts no responsibility or liability for the use of this report by any third party. The disclosure or distribution of this report to third parties is not permitted unless written approval is granted by ARES Project Services Pty Ltd.

Introduction

Beenup WF is a proposed renewable energy development located in Western Australia, consisting of up to 30 wind turbine generators with blades up to 90m long. The project is located approximately 300km south of Perth and 15km north-east of Augusta, in the Shire of Augusta Margaret River.

Ares have been tasked by our customer, SynergyRED, to undertake a Route Survey from the Port of Bunbury to site. The purpose of the study is to determine the pinch points along the route and give best estimates of modifications and works required to enable oversize overmass (OSOM) cargo to be brought to site.

The study is designed for those involved in the project that have a limited knowledge of transportation, including a comprehensive outline of the routes and actions required to achieve delivery.



Murra Warra WF

Murra Warra Stage 1 components had to be transported over 250km from the Port of Portland to site. Cargo included 5.8m diameter towers such as these pictured.



01

Overview

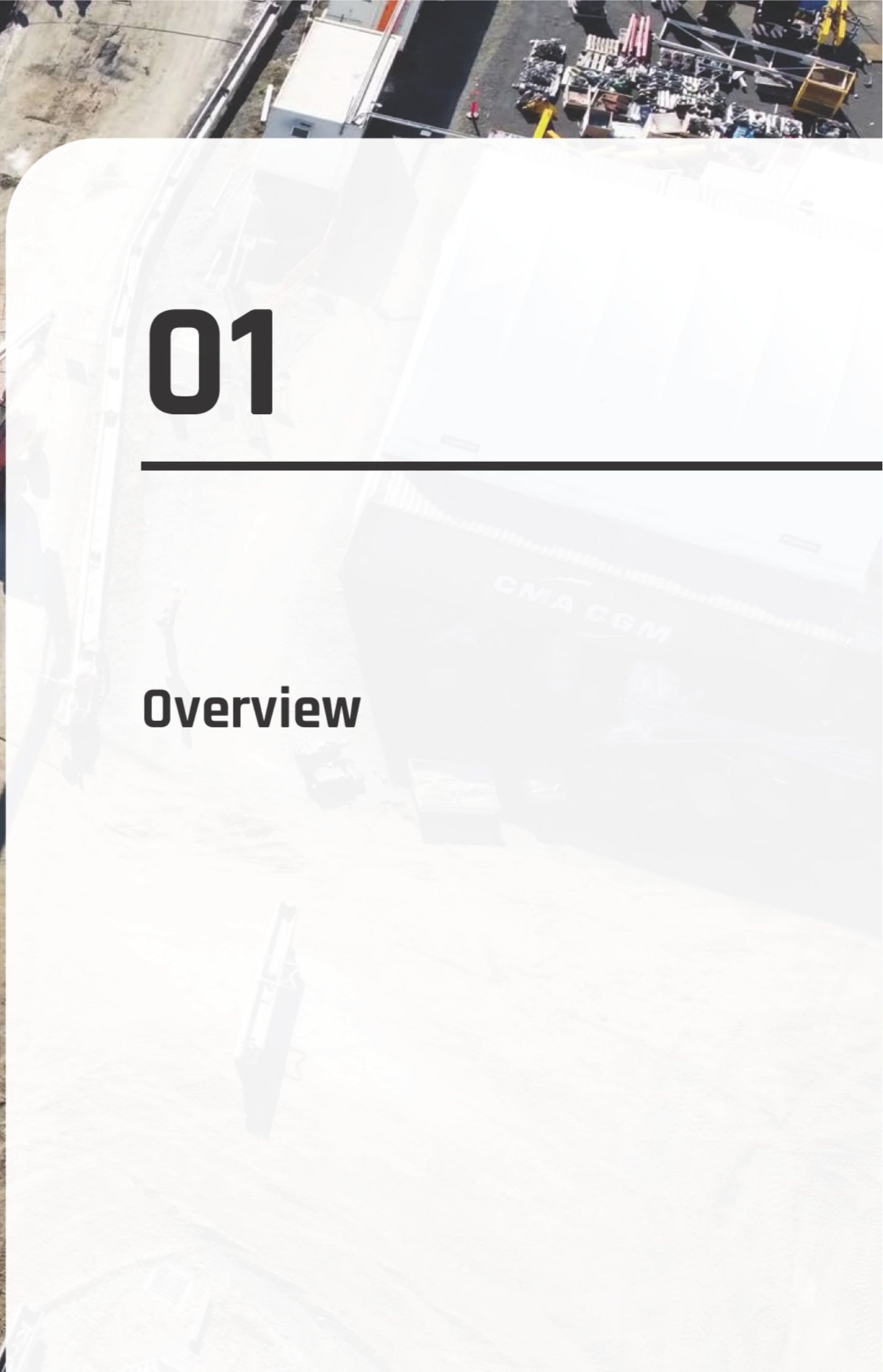

Project Overview

The Beenup WF is a renewable energy development in the south western region of WA currently in the planning and approvals stage.

Scope of Survey

Beenup WF is located in the south west corner of Western Australia, 15km north-east of the town of Augusta.

ARES has been tasked with surveying the route from the proposed Port of Import (Bunbury) to the construction site. The survey includes everything from the discharge berth, transfer to port storage area, road transport from port to site, and an assessment of the turns into potential site entrances.

ARES physically drove the route in March 2024. The aim of the drive was to visually verify the results of an initial desktop study, take physical measurements and obtain drone footage at pinch points where the existing aerial imagery from sources such as Google and Nearmaps was of insufficient quality.

No engagement has been undertaken with the transport authority (Main Roads WA) as yet, as the project is still in the early stages of planning. Once the project scope and route firms, we highly recommend engaging with MRWA as soon as possible to firm up OSOM transport and permit requirements.

Port of Import

The Port of Bunbury serves as a vital import/export hub into the south western region of WA. Much of its operation is driven by mineral, grain and wood exports, and a diverse range of bulk import materials. In recent

years, driven by the renewable energy boom, the port has played host to wind turbine components, most recently for the Flat Rocks Wind Farm project in 2023.

The primary berth for break bulk cargo is the general purpose Berth 5, which has large storage areas (~60,000sqm total) nearby to the berth. The layout of the port area is shown in the bird's eye view to the right.

Bunbury Port has excellent connections to both road and rail. For heavy vehicle traffic, there are direct connections to highways to the north, south and east which bypass the built up areas around the town, and the area is generally clear of bridges and other overhead obstructions.

Site

The project construction site is accessed east off Scott River Rd. Due to the early stage of the project, the site access point(s) have not been confirmed, but ARES surveyed four potential entry points as part of our scope.

The wind farm is located in primarily agricultural land and the topography is very flat. There should be no issues with steep gradients on site roads.



Above: Aerial view of Bunbury Port, showing berth (red) and storage areas (green). **Below:** Flat Rocks WF, built in similar terrain to Beenup. (Credit: ABC)



Transport Methodology

Specialised cargo requires specialised transport solutions.

Cargo Dimensions

The transport envelope assumed for this route survey will be as follows:

- Length: 90.2m (Sinoma S190.2 Blade)
- Width & Height: 6.0m (Base tower section)

The other wind turbine components such as nacelle, drivetrain, hub and other tower sections will fall within this envelope and are hence not considered separately.

The blade is one of the longest known blades of the latest 7MW generation of wind turbine generators which are starting to enter the market. The height of the blade is listed at 3.6m which means that height will not be an issue.

The spacing of the support frames for the blade is important, as this changes the swept path of the trailer. The Sinoma blade has a tip frame spacing of 48m, leaving a rather large overhang of 42m. This means the blade tip will tend to oversail fencelines and stray into private property, and makes avoiding tall assets such as light poles and power poles difficult. Transporting with such a large overhang may also be subject to approval from Main Roads WA.

It is recommended to engage with the blade manufacturer further to see if other tip spacing options are available, such as one which gives a more typical overhang of around 30m.

Tower dimensions are not yet available but we have assumed a diameter of around 6.0m for the widest section, which is typical for a wind turbine tower with hub height of around 120-160m.

Equipment

As an exact turbine model has not been selected, ARES have made some general assumptions on the trailing equipment required to transport a typical next generation wind turbine, shown in the equipment schematic overleaf. This is meant as a rough guide only and designed to give an idea of the sizes of equipment involved.

The exception is the Sinoma blade, for which we have exact dimensions and hence has been modelled accurately.

The trailing equipment required to carry the components to site are already in use by specialist oversize transporters in Australia. The blades can be transported by conventional extendable blade trailers or fixed length trailers. The largest towers will likely be transported on either bookend style trailers or low bed platform trailers to keep the transport height down to reduce the number of power lines requiring lifting.

The remainder of components can be transported on platform and low loader trailers which are very commonly used.



Above: Bookend Trailers used by ARES for Murra Warra's 5.8m towers

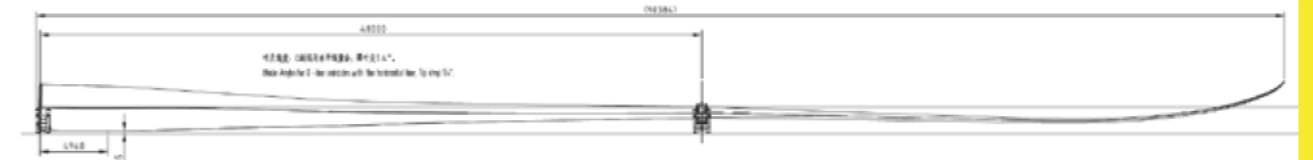

Above: Schematic of Sinoma S190.2 wind turbine blade



Above: Extendable blade trailers loaded with 75m blades for the Yandin project in Western Australia.

Equipment Schematic

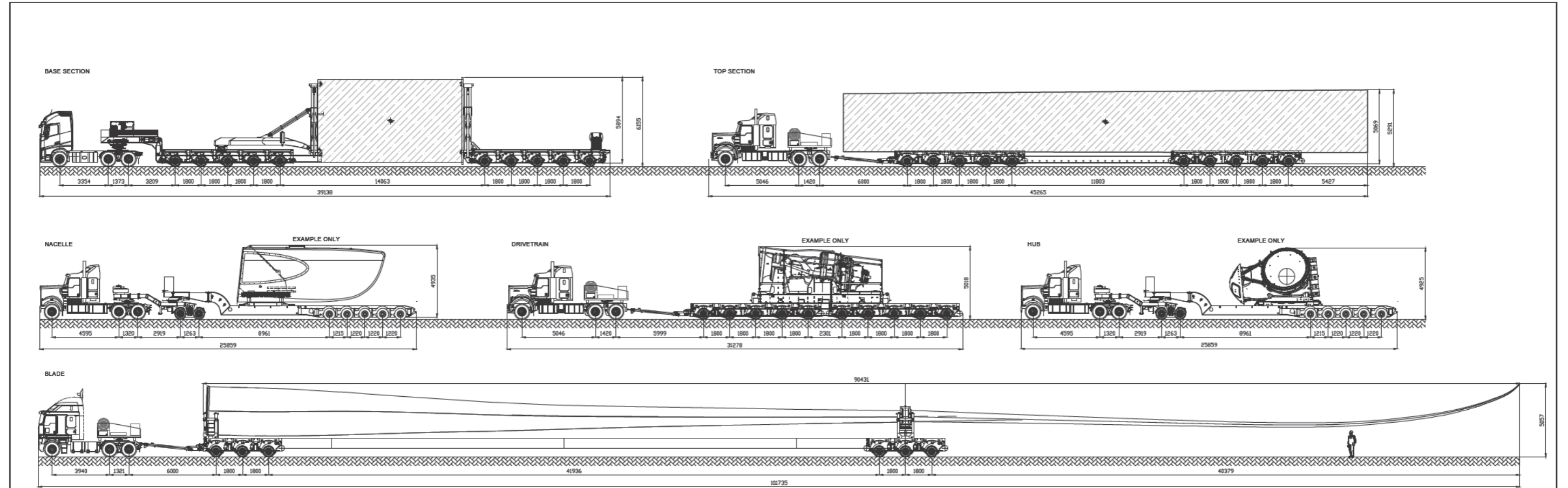

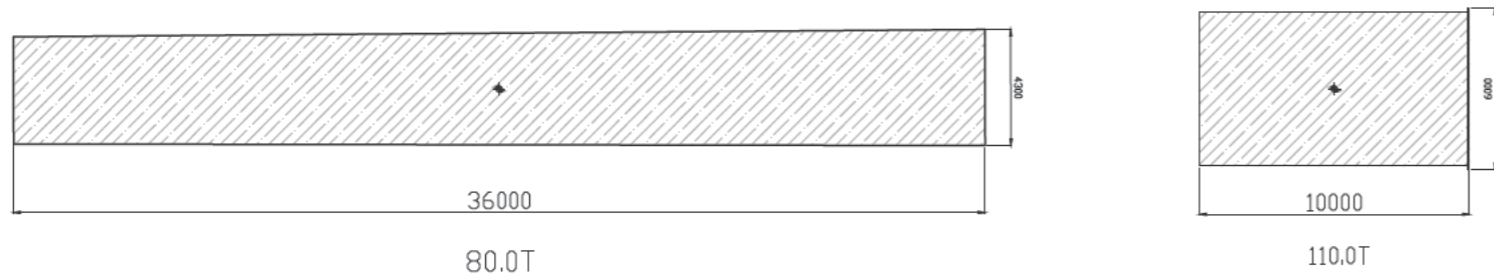

Tower Specifications

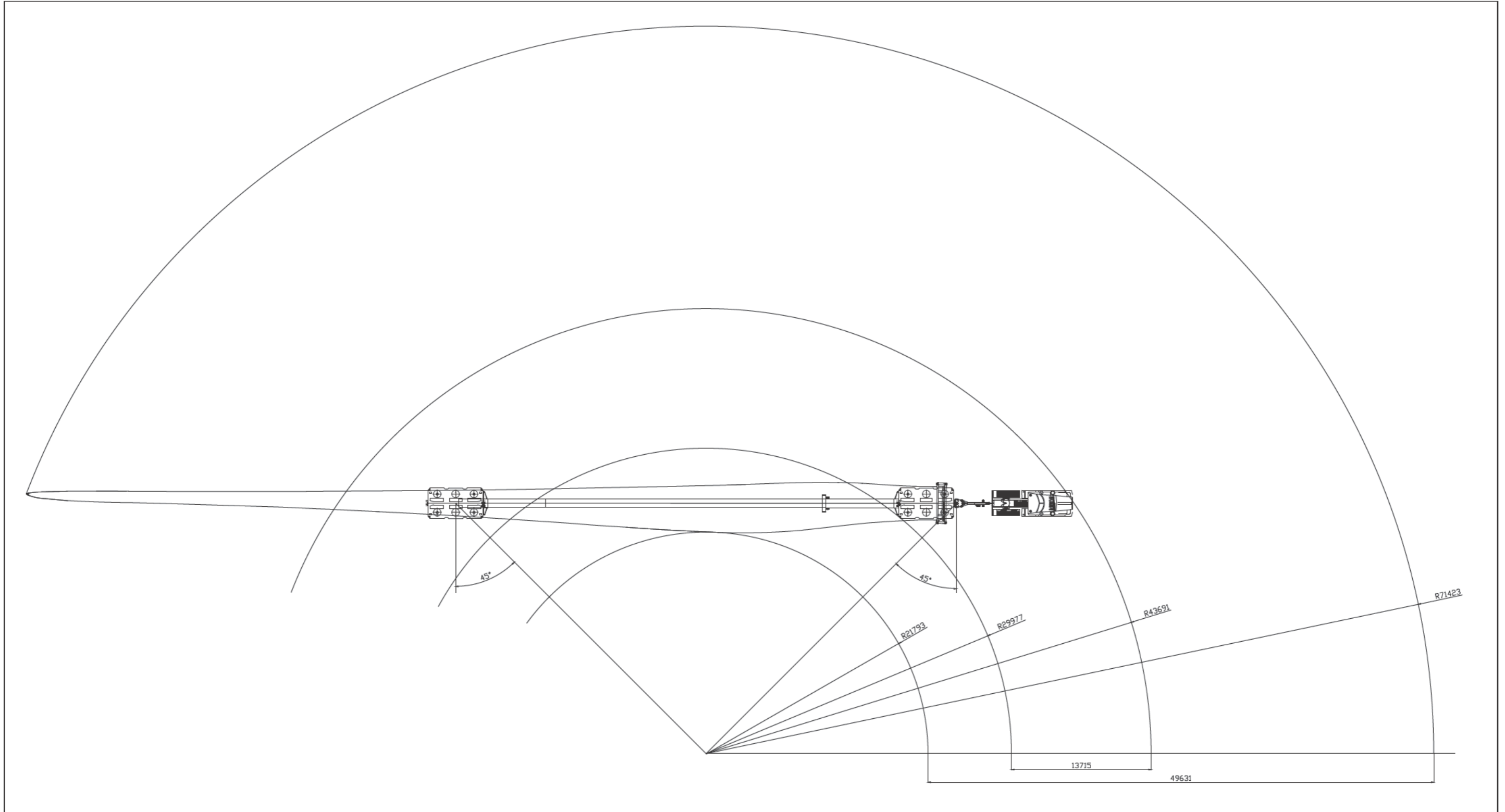

						DRAWING NOTES: ALL DIMENSIONS ARE IN mm UNLESS NOTED OTHERWISE (UNO) ALL WEIGHTS ARE IN t (METRIC TONNES) UNO ALL DETAILS ARE PROVISIONAL AND SUBJECT TO CONFIRMATION LASHINGS CALCULATIONS AS PER RESTRAINT GUIDELINES		TECHNICAL NOTES: WEIGHT, DIMENSIONS AND COG POSITION TO BE CONFIRMED BY CLIENT STRUCTURAL INTEGRITY TO BE CHECKED BY CLIENT OPERATIONAL DIAGRAMS AND MANUAL MUST BE OBSERVED HYDRAULIC STABILITY REFERS TO STATIC LOAD ONLY STABILITY PROVISIONAL UNTIL COG CONFIRMED		COPYRIGHT 2024 THE CONTENTS OF THIS DRAWING REMAINS THE PROPERTY OF ARES PROJECT SERVICES PTY LTD. NO CONTENTS MAY NOT BE COPIED OR REPRODUCED UNLESS AUTHORIZATION HAS BEEN PREVIOUSLY GIVEN, IN WRITING FROM ARES PROJECT SERVICES PTY LTD. THE CONTENTS OF THIS DRAWING ARE FOR THE PURPOSE OF TRANSPORT PLANNING, AND / OR TRANSPORT PROPOSAL. ALL DRAWINGS ARE TO BE USED AS A GUIDELINE ONLY.				CUSTOMER: SynergyRED PROJECT: Beenup WF DRAWING TITLE: Equipment Schematic DRAWING NAME: SYNERGY_BEENUP_R0		SIZE: NTS SHEET NO: REV	
REV	DATE	DESCRIPTION	DRN	CHK	APP	REFERENCE DRAWINGS	ARES PROJECT SERVICES PTY LTD - ABN: 45 643 587 115						DRAWN BY:	DRAWN DATE:	CHECKED BY:		

Blade Trailer Turning Circle



						DRAWING NOTES: ALL DIMENSIONS ARE IN mm UNLESS NOTED OTHERWISE (UNO) ALL WEIGHTS ARE IN t (METRIC TONNES) UNO ALL DETAILS ARE PROVISIONAL AND SUBJECT TO CONFIRMATION LASHINGS CALCULATIONS AS PER RESTRAINT GUIDELINES		TECHNICAL NOTES: WEIGHT, DIMENSIONS AND COG POSITION TO BE CONFIRMED BY CLIENT STRUCTURAL INTEGRITY TO BE CHECKED BY CLIENT OPERATIONAL DIAGRAMS AND MANUAL MUST BE OBSERVED HYDRAULIC STABILITY REFERS TO STATIC LOAD ONLY STABILITY PROVISIONAL UNTIL COG CONFIRMED		COPYRIGHT 2024 THE CONTENTS OF THIS DRAWING REMAINS THE PROPERTY OF ARES PROJECT SERVICES PTY LTD. NO CONTENTS MAY NOT BE COPIED OR REPRODUCED UNLESS AUTHORIZATION HAS BEEN PREVIOUSLY GIVEN, IN WRITING FROM ARES PROJECT SERVICES PTY LTD. THE CONTENTS OF THIS DRAWING ARE FOR THE PURPOSE OF TRANSPORT PLANNING, AND / OR TRANSPORT PROPOSAL. ALL DRAWINGS ARE TO BE USED AS A GUIDELINE ONLY.				CUSTOMER: SynergyRED PROJECT: Beenup WF DRAWING TITLE: Blade Trailer Turning Circle DRAWING NAME: SYNERGY_BEENUP_R0		SIZE: SCALE: SHEET NO: REV:	
REV	DATE	DESCRIPTION	DRN	CHK	APP	REFERENCE DRAWINGS		ARES PROJECT SERVICES PTY LTD - ABN: 45 643 587 115		DRAWN BY:		DRAWN DATE:		CHECKED BY:			

Port Operations at Bunbury

Information pertaining to vessel discharge operations and transfer of cargo to short term storage/ laydown.

Ship Discharge

Berth 5 has a length of 240m and has ample room for manoeuvring trucks and trailers during discharge operations. Trailers required would be blade trailers for the blades, platform trailers (up to 12 axles) for large tower sections and heavier components such as the drivetrain, and low loaders for the other components.

Loading of components onto trailers is expected to be via ship's cranes.

Transfer to Storage

Components follow the route shown on the right to the storage area around 200m away. Care will need to be taken for longer loads such as blades and top tower sections when turning and reversing, and a rear pilot or spotter may be required.

The main storage area has around 35,000sqm of space. There is a further 25,000sqm of space in a secondary area to the south-east which can be used for smaller components. Security fencing, lighting and power will have to be self-provided.

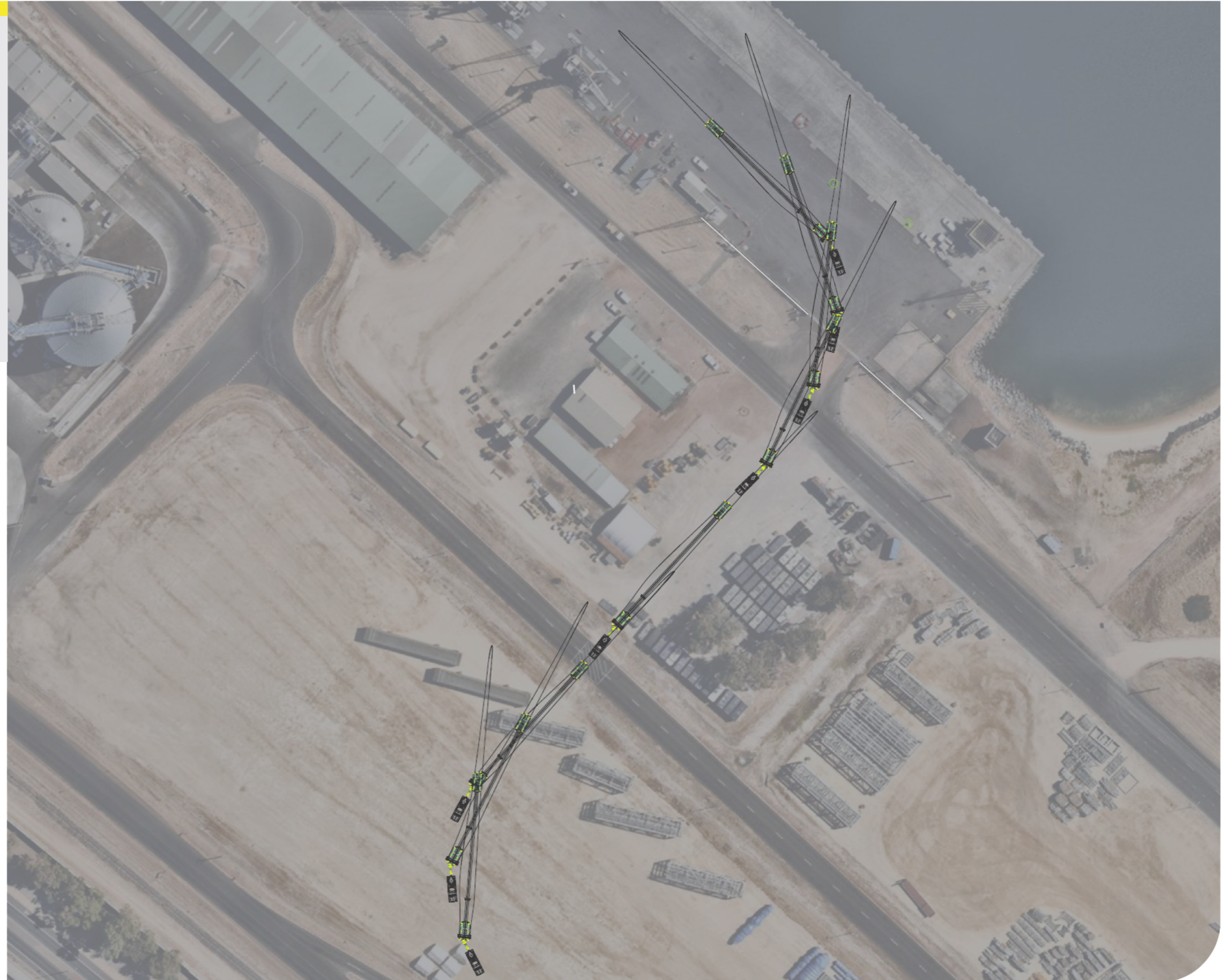



02

**Route 1 - Bunbury to
Beenup WF**

Route Overview

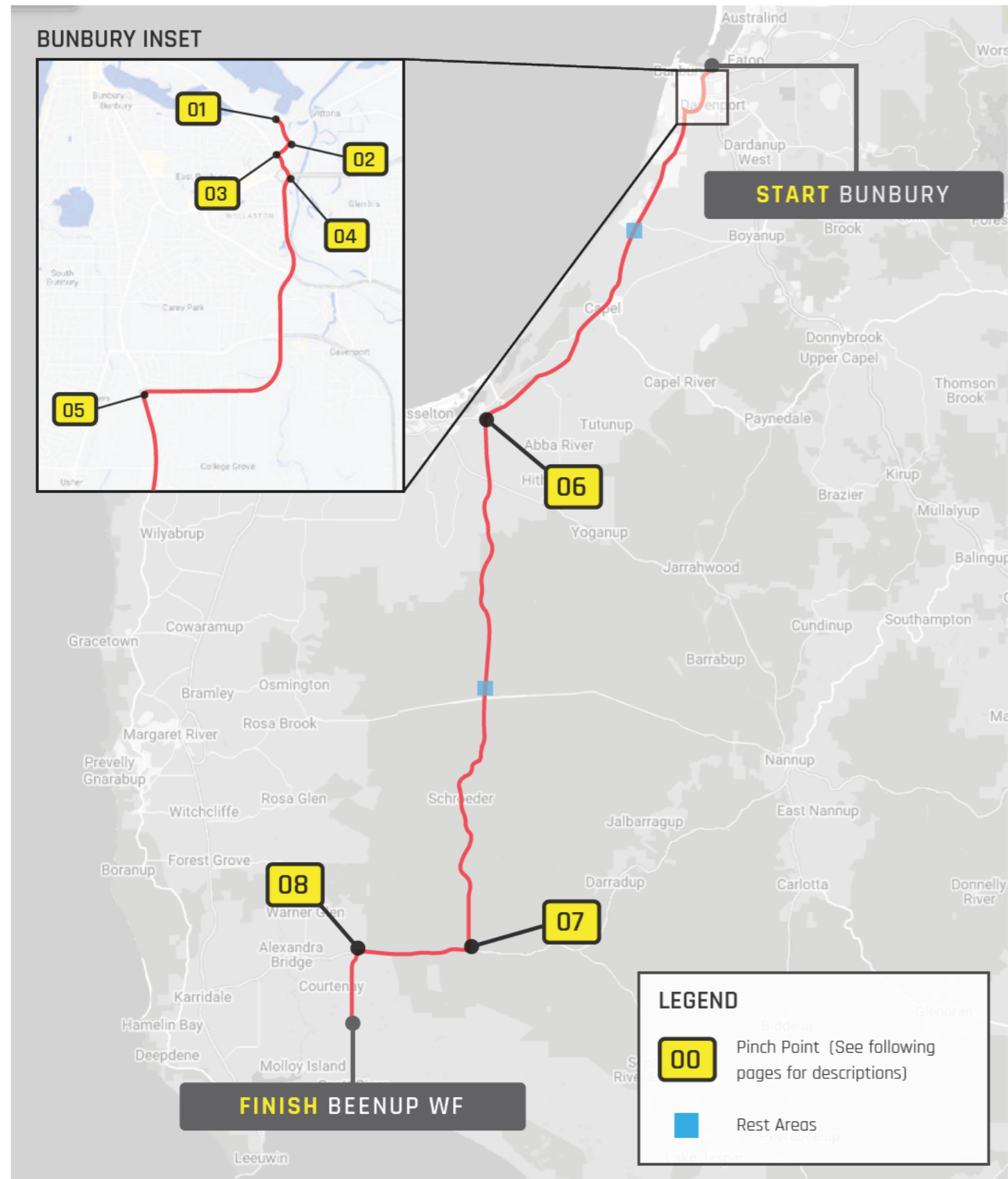

ROUTE 1

- 0.0 KM **START - Bunbury**
- 0.4 KM Leschenault Dr
- 0.6 KM Estuary Dr
- 3.4 KM Koombana Dr
- 6.2 KM Robertson Dr
- 46.5 KM Bussell Hwy
- 105.3 KM Sues Rd
- 116.9 KM Brockman Hwy
- 125.1 KM Scott River Rd
- FINISH - Beenup WF**

[INTERACTIVE MAP LINK](#)

This route is suitable for all components.

Exiting Bunbury (KP0.0 - KP5.2)

This first section of the route will be slowest due to the number of turns and presence of roadside infrastructure. It is expected that components will leave port in the early morning to clear the Bunbury metro area with as little disruption as possible.

The roads are all dual lane to Bussell Hwy with the exception of Leschanault Dr.

Bussell Hwy (KP5.2 - KP46.5)

Bussell Hwy is a state maintained highway. There are currently duplication works which will see the road being dual carriageway to Sues Rd (estimated to be complete in mid to late 2024). There are no issues with this section of road.

Sues Rd (KP46.5 - KP105.3)

Sues Rd is a major north-south thoroughfare in the area and is an approved B-double route. Whilst single lane, the road is around 7-8m wide along most of its length, and is suitable to take turbine components along. There are a number of winding sections which will require the Traffic Warden and supporting pilots to stop oncoming traffic as the blade tip will swing into the opposite lane.

Brockman Hwy/Scott River Rd (KP105.3 - KP125.1)

Brockman Hwy is a state maintained, single lane road. The section connecting Sues Rd to Scott River Rd is suitable for OSOM traffic but goes through forest and clearance for longer loads will need to be monitored.

Scott River Rd is also single lane, around 6.0-6.5m wide and paved for about 8.5km before becoming gravel. The initial section is through forest before opening up into farmland further south.

Rest Areas

The following locations are suitable for all combinations including blade trailers to stop at.

KP20.5 Truck Parking Area, Bussell Hwy
GPS: <https://maps.app.goo.gl/xmyjy2Fr96YhgHmL6>

KP52.6 Truck Parking Area, Sues Rd
GPS: <https://maps.app.goo.gl/SRJ77wghzNzvUNZf8>

Bunbury to Beenup WF

General Route Notes

Road Quality

The transport route is mainly along state maintained highways and roads, which are generally designed to a higher specification and able to handle heavier and higher volumes of traffic.

The entire route is paved, with the exception of a short section of gravel on Scott River Rd (approx. 500m) leading up to the southernmost site entry option.

Overhead Structures

There are no overhead structures such as bridges or overpasses on the route.

Overhead Power Lines

In general, a travel height below around 5.5m is not an issue with respect to power lines. Loads above 5.2m travel height will require a high load permit from the power authorities prior to travel.

An overhead powerline survey (performed by the power authority) is recommended to determine exact line heights and ascertain if any lines need to be temporarily or permanently lifted prior to the load going through.

For this project, with tower sections up to 6.0m in diameter, high load permits will be required. High wire

escorts may also be required to accompany the loads and perform any line lifting needed. This will need to be confirmed with the power authorities.

The route traverses through the Western Power distribution network.

Bridges and Culverts

There are only a few bridge and culvert crossings along the route. These are listed below. Consultation with Main Roads WA will be required to ascertain if there are any special requirements to cross these structures, such as axle load limits, speed restrictions, bridge video supervision etc.

Sues Rd over Sabina River
GPS: <https://maps.app.goo.gl/Bb2jM2H4oLjkv7Qc8>

Sues Rd over cattle underpass
GPS: <https://maps.app.goo.gl/iudWTuAD9JLQzjhF7>

Sues Rd over East Wonnerup drain
GPS: <https://maps.app.goo.gl/4MsEyrV66u2CMRKJ9>

Sues Rd over cattle underpass (Sanson Section)
GPS: <https://maps.app.goo.gl/WQTBZ9cB7feuENxx8>

Sues Rd over Blackwood River
GPS: <https://maps.app.goo.gl/omnMqfEUsULAt4NN8>

There are a number of minor culverts along Scott River Rd which will need assessment by the local shire.

Note: Bussell Hwy bridges have not been listed, these are assumed to be built to higher specification and suitable for heavy vehicles.

Rail Crossings

There are two rail level crossings along the route as noted below. Permissions will be required from rail authorities to travel through these crossings.

Inner Harbour Access Rd Level Crossing
Rail Authority: Arc Infrastructure
GPS: <https://maps.app.goo.gl/nPbDgA4M42k8nCFPA>

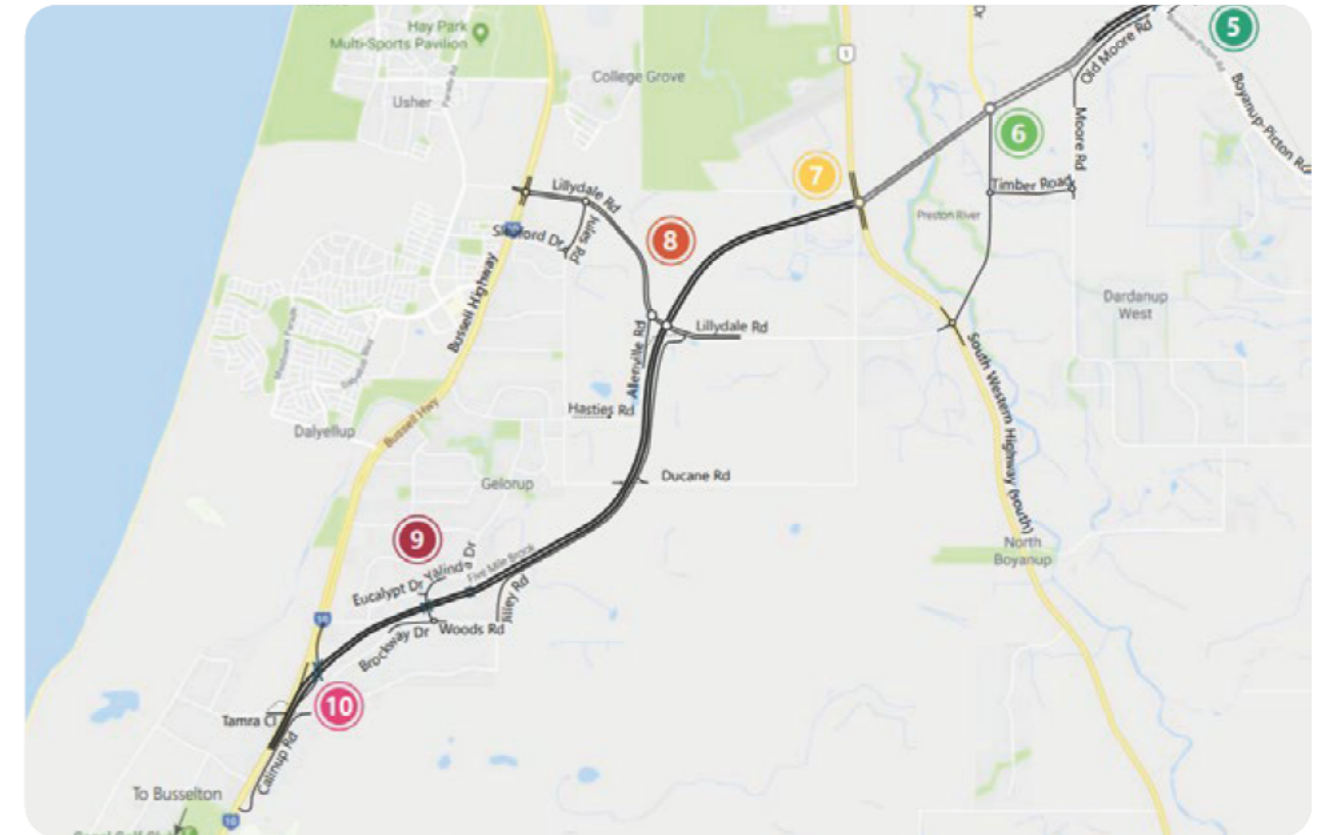

Above: Bunbury Bypass concept design. (Source: Main Roads WA)

Robertson Dr Level Crossing
Rail Authority: Arc Infrastructure
GPS: <https://maps.app.goo.gl/9tpaZDqCesmvha1G6>

Roadworks

There are a number of road upgrade projects planned along the route which may affect transport of project components, depending on timing. These may lead to speed restrictions, curfews, dimensional restrictions, detours or possibly a full halt on deliveries. It is recommended that close liaison with MRWA is maintained throughout the project planning phase to keep abreast of any developments on the following projects, as well as any others which are not yet known:

- Bunbury Outer Ring Road project - estimated completion date Q4 2024
- Bussell Highway Duplication project - estimated completion date Q4 2024

Approvals

All OSOM loads will require Permits from Main Roads WA prior to travel. The permits will state the approved route(s), vehicles and any special conditions which apply to travel. Transport operators will need to hold WA Heavy Vehicle Accreditation.

Blades are classified as "high risk OSOM" moves by MRWA and will require an approved OSOM Transport Management Plan in addition to a Permit.

Modifications to State Roads in WA will require review and approval from MRWA. Modifications to local roads will require approval from the local shire or council.

Third party approvals required include the port authority, rail authorities, and utility providers such as electricity and telecommunications.

Pinch Point

01

COMPOUND TURN
Port Storage &
Leschenault Dr

ROUTE 1

Loads leaving the port storage area in Port of Bunbury will need to negotiate a few turns within the Port area.

The initial left turn out of storage is achievable but the tip clearance to the power pole to the south is tight and will have to be watched closely by spotters. Some additional hard stand on the inside of the corner will provide some additional margin for error if necessary.

The following right turn is manageable as well, as the rear of the trailer can run on hard stand already placed on the outside of the corner from previous projects. The blade tip should clear the top of the sign on the outside.

Loads will take the bypass road around the main gate to exit the secured area. See following page for completion of this pinch point.



<p>COPYRIGHT 2023</p> <p>THE CONTENTS OF THIS DRAWING REMAINS THE PROPERTY OF ARES PROJECT SERVICES PTY LTD. NO CONTENTS MAY NOT BE COPIED OR REPRODUCED UNLESS AUTHORIZATION HAS BEEN PREVIOUSLY GIVEN, IN WRITING FROM ARES PROJECT SERVICES PTY LTD. THE CONTENTS OF THIS DRAWING ARE FOR THE PURPOSE OF TRANSPORT PLANNING, AND / OR TRANSPORT PROPOSAL. ALL DRAWINGS ARE TO BE USED AS A GUIDELINE ONLY.</p> <p>DRAWING NOTES:</p> <p>ALL DIMENSIONS ARE IN mm UNLESS NOTED OTHERWISE (UNO) ALL WEIGHTS ARE IN t (METRIC TONNES) UNO ALL DETAILS ARE PROVISIONAL AND SUBJECT TO CONFIRMATION LASHINGS CALCULATIONS AS PER RESTRAINT GUIDELINES</p>		CUSTOMER:	SynergyRED	SIZE:	
		PROJECT:	Beenup WF	SCALE NTS	
	DRAWN BY:		DRAWING TITLE:	SWEPT PATH DRAWING	SHEET NO:
	DRAWN DATE:		DRAWING NAME:	Route Survey	REV
CHECKED BY:		ARES PROJECT SERVICES PTY LTD - ABN: 45 643 587 115			

Pinch Point

01

COMPOUND TURN
Port Storage &
Leschenault Dr

ROUTE 1

(continued)

Blades will need to take the final turn onto Leschenault Dr with care due to the presence of power and light poles on either side of the bypass road.

There is existing hard stand on the outside of the corner from previous projects but for a 90m blade this will need to be extended.

The blade can then drive straight over the rail crossing and past the guard house to exit the port.

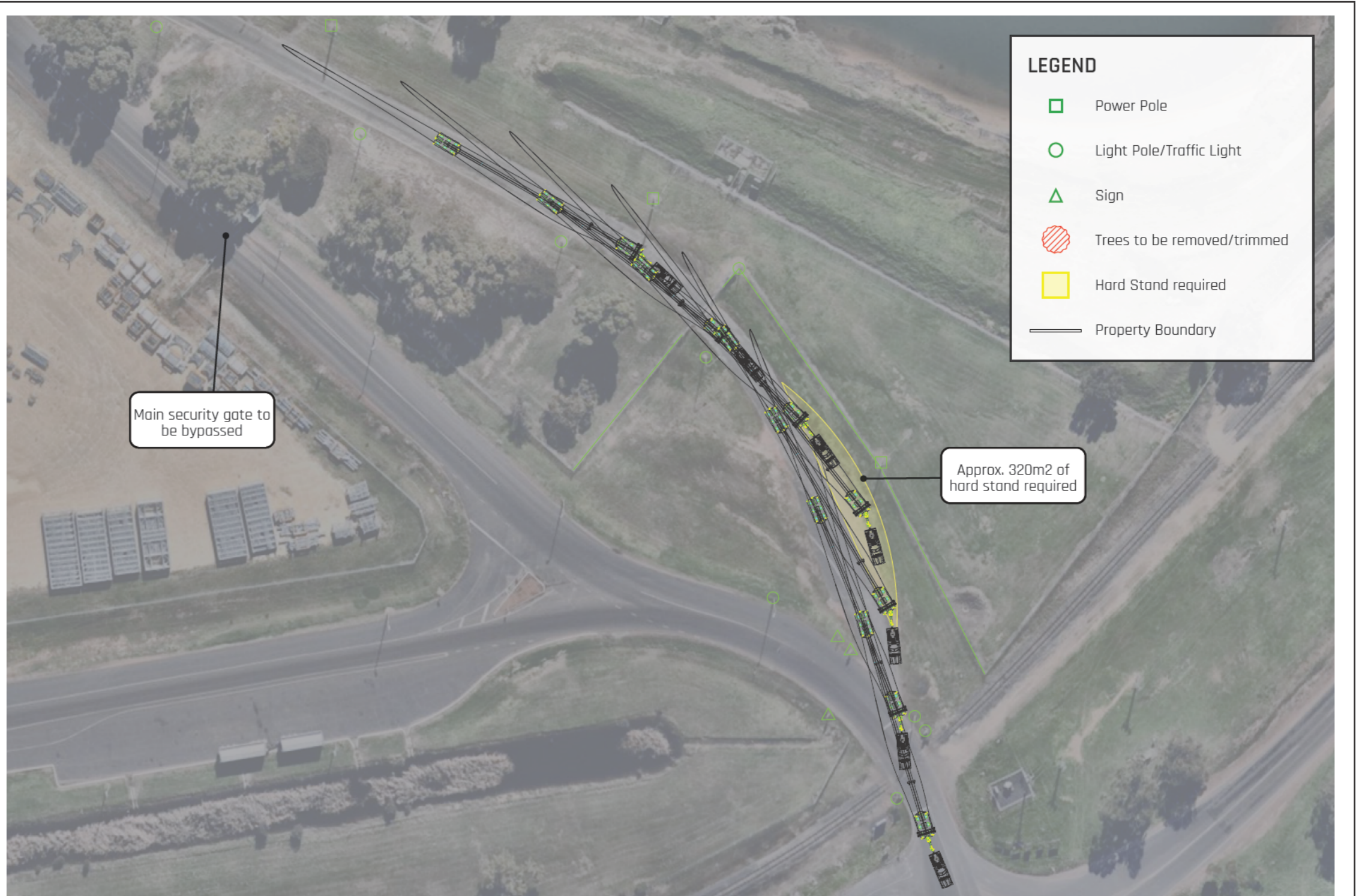

<p>COPYRIGHT 2023</p> <p>THE CONTENTS OF THIS DRAWING REMAINS THE PROPERTY OF ARES PROJECT SERVICES PTY LTD. NO CONTENTS MAY NOT BE COPIED OR REPRODUCED UNLESS AUTHORIZATION HAS BEEN PREVIOUSLY GIVEN, IN WRITING FROM ARES PROJECT SERVICES PTY LTD. THE CONTENTS OF THIS DRAWING ARE FOR THE PURPOSE OF TRANSPORT PLANNING, AND / OR TRANSPORT PROPOSAL. ALL DRAWINGS ARE TO BE USED AS A GUIDELINE ONLY.</p> <p>DRAWING NOTES:</p> <p>ALL DIMENSIONS ARE IN mm UNLESS NOTED OTHERWISE (UNO) ALL WEIGHTS ARE IN t (METRIC TONNES) UNO ALL DETAILS ARE PROVISIONAL AND SUBJECT TO CONFIRMATION LASHINGS CALCULATIONS AS PER RESTRAINT GUIDELINES</p>	 www.aresgroup.com.au	CUSTOMER: SynergyRED	SIZE:
		PROJECT: Beenup WF	SCALE NTS
	DRAWN BY:	DRAWING TITLE: SWEPT PATH DRAWING	SHEET NO:
	DRAWN DATE:	DRAWING NAME: Route Survey	REV
CHECKED BY:	ARES PROJECT SERVICES PTY LTD - ABN: 45 643 587 115		

Pinch Point

02

RIGHT TURN
Leschenault Dr
& Estuary Dr

ROUTE 1

The roundabout onto Estuary Dr will need to be taken on the incorrect side by blades. To prevent the tip swing from impacting trees to the north, the inside of the corner will need a moderate amount of hard stand material to allow the load to cut the corner, and some existing wire fencing will need to be shortened. A light pole on the inside will also need to be moved.

Clearance to a number of signs will need to be checked during a trial run to ensure the tip can pass safely over them. If not, they will need to be made removeable.

Traffic wardens will hold traffic on Estuary Dr while the turn is being completed.



<p>COPYRIGHT 2023</p> <p>THE CONTENTS OF THIS DRAWING REMAINS THE PROPERTY OF ARES PROJECT SERVICES PTY LTD. NO CONTENTS MAY NOT BE COPIED OR REPRODUCED UNLESS AUTHORIZATION HAS BEEN PREVIOUSLY GIVEN, IN WRITING FROM ARES PROJECT SERVICES PTY LTD. THE CONTENTS OF THIS DRAWING ARE FOR THE PURPOSE OF TRANSPORT PLANNING, AND / OR TRANSPORT PROPOSAL. ALL DRAWINGS ARE TO BE USED AS A GUIDELINE ONLY.</p> <p>DRAWING NOTES:</p> <p>ALL DIMENSIONS ARE IN mm UNLESS NOTED OTHERWISE (UNO) ALL WEIGHTS ARE IN t (METRIC TONNES) UNO ALL DETAILS ARE PROVISIONAL AND SUBJECT TO CONFIRMATION LASHINGS CALCULATIONS AS PER RESTRAINT GUIDELINES</p>		CUSTOMER:	SynergyRED	SIZE:
		PROJECT:	Beenup WF	SCALE NTS
	DRAWN BY:	DRAWING TITLE:	SWEPT PATH DRAWING	SHEET NO:
	DRAWN DATE:	DRAWING NAME:	Route Survey	REV
	CHECKED BY:	ARES PROJECT SERVICES PTY LTD - ABN: 45 643 587 115		

Pinch Point

03

LEFT TURN
Estuary Dr &
Koombana Dr

ROUTE 1

To avoid the row of trees on the main traffic island on Estuary Dr, blades will have to stay straight for as long as possible, crossing over the median onto the incorrect side of Koombana Dr before turning sharply left, and crossing back over to the correct side.

One 'Give Way' sign will have to be relocated or temporarily removed, and the inside of the corner will need to be made trafficable.

Traffic wardens will hold traffic on Koombana Dr while the blade contraflows the intersection.



COPYRIGHT 2023 THE CONTENTS OF THIS DRAWING REMAINS THE PROPERTY OF ARES PROJECT SERVICES PTY LTD. NO CONTENTS MAY NOT BE COPIED OR REPRODUCED UNLESS AUTHORIZATION HAS BEEN PREVIOUSLY GIVEN, IN WRITING FROM ARES PROJECT SERVICES PTY LTD. THE CONTENTS OF THIS DRAWING ARE FOR THE PURPOSE OF TRANSPORT PLANNING, AND / OR TRANSPORT PROPOSAL. ALL DRAWINGS ARE TO BE USED AS A GUIDELINE ONLY. DRAWING NOTES: ALL DIMENSIONS ARE IN mm UNLESS NOTED OTHERWISE (UNO) ALL WEIGHTS ARE IN t (METRIC TONNES) UNO ALL DETAILS ARE PROVISIONAL AND SUBJECT TO CONFIRMATION LASHINGS CALCULATIONS AS PER RESTRAINT GUIDELINES	 www.aresgroup.com.au	CUSTOMER: SynergyRED	SIZE:
		PROJECT: Beenup WF	SCALE NTS
	DRAWN BY:	DRAWING TITLE: SWEPT PATH DRAWING	SHEET NO:
	DRAWN DATE:	DRAWING NAME: Route Survey	REV
	CHECKED BY:	ARES PROJECT SERVICES PTY LTD - ABN: 45 643 587 115	

Pinch Point

04

ROUNDBABOUT
Eelup Rotary

ROUTE 1

The large Eelup Rotary roundabout can be taken with minimal modifications - only one sign has to be made removeable. However, due to the number of light poles, traffic lights and signs in the vicinity, extra care and vigilance will need to be taken.



COPYRIGHT 2023 THE CONTENTS OF THIS DRAWING REMAINS THE PROPERTY OF ARES PROJECT SERVICES PTY LTD. NO CONTENTS MAY NOT BE COPIED OR REPRODUCED UNLESS AUTHORIZATION HAS BEEN PREVIOUSLY GIVEN, IN WRITING FROM ARES PROJECT SERVICES PTY LTD. THE CONTENTS OF THIS DRAWING ARE FOR THE PURPOSE OF TRANSPORT PLANNING, AND / OR TRANSPORT PROPOSAL. ALL DRAWINGS ARE TO BE USED AS A GUIDELINE ONLY. DRAWING NOTES: ALL DIMENSIONS ARE IN mm UNLESS NOTED OTHERWISE (UNO) ALL WEIGHTS ARE IN t (METRIC TONNES) UNO ALL DETAILS ARE PROVISIONAL AND SUBJECT TO CONFIRMATION LASHINGS CALCULATIONS AS PER RESTRAINT GUIDELINES	 www.aresgroup.com.au	CUSTOMER: SynergyRED	SIZE:
		PROJECT: Beenup WF	SCALE NTS
	DRAWN BY:	DRAWING TITLE: SWEPT PATH DRAWING	SHEET NO:
	DRAWN DATE:	DRAWING NAME: Route Survey	REV
	CHECKED BY:	ARES PROJECT SERVICES PTY LTD - ABN: 45 643 587 115	

Pinch Point

05

LEFT TURN
Robertson Dr
& Bussell Hwy

ROUTE 1

The turn onto Bussell Hwy is acute and will require traversing over the traffic islands, but the combination can remain on the correct side of the road. A number of signs will need to be made removeable on the traffic island and medians.

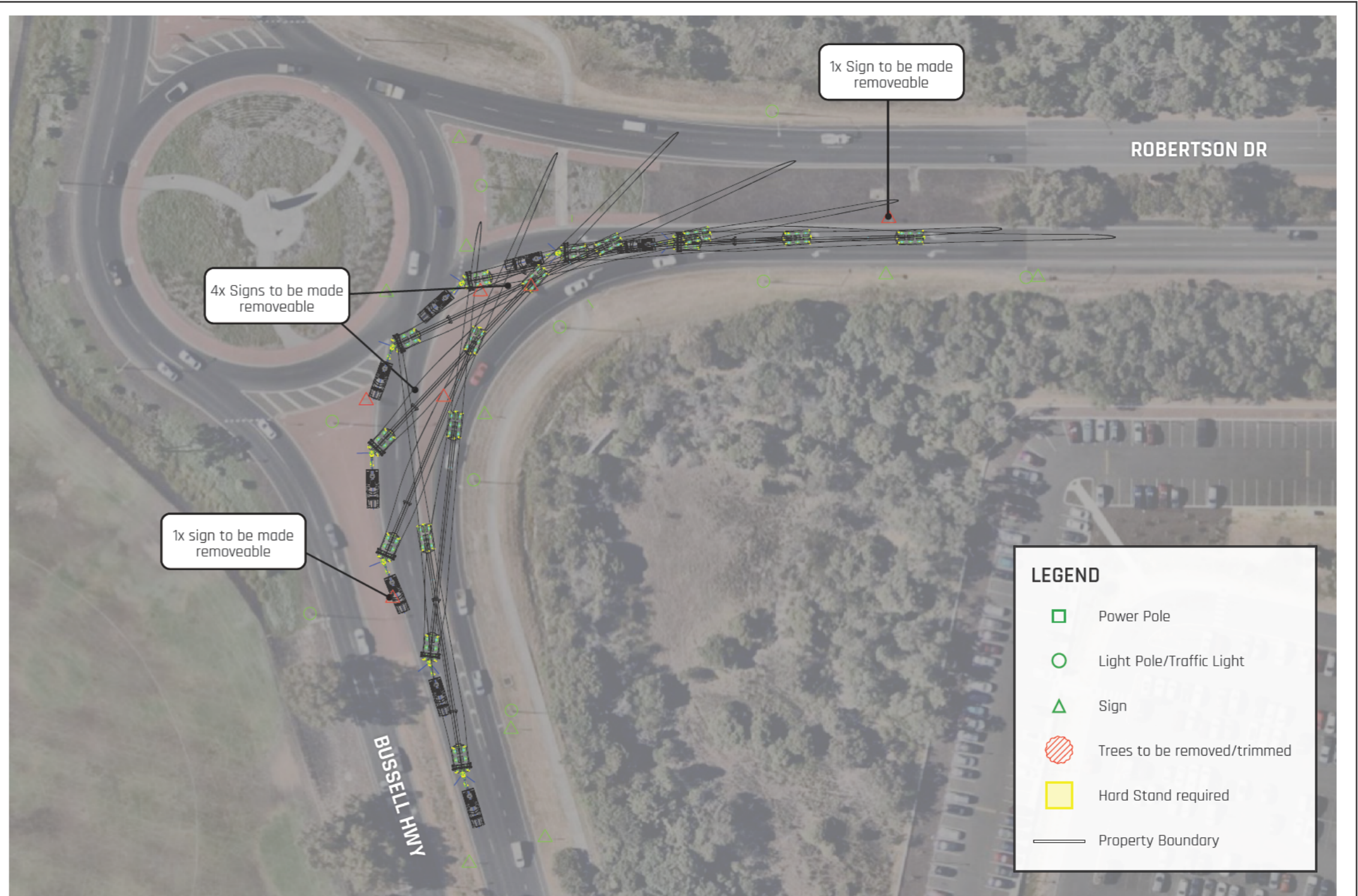

COPYRIGHT 2023

THE CONTENTS OF THIS DRAWING REMAINS THE PROPERTY OF ARES PROJECT SERVICES PTY LTD. NO CONTENTS MAY NOT BE COPIED OR REPRODUCED UNLESS AUTHORIZATION HAS BEEN PREVIOUSLY GIVEN, IN WRITING FROM ARES PROJECT SERVICES PTY LTD. THE CONTENTS OF THIS DRAWING ARE FOR THE PURPOSE OF TRANSPORT PLANNING, AND / OR TRANSPORT PROPOSAL. ALL DRAWINGS ARE TO BE USED AS A GUIDELINE ONLY.

DRAWING NOTES:

ALL DIMENSIONS ARE IN mm UNLESS NOTED OTHERWISE (UNO) ALL WEIGHTS ARE IN t (METRIC TONNES) UNO ALL DETAILS ARE PROVISIONAL AND SUBJECT TO CONFIRMATION LASHINGS CALCULATIONS AS PER RESTRAINT GUIDELINES



CUSTOMER:	SynergyRED	SIZE:
PROJECT:	Beenup WF	SCALE NTS
DRAWING TITLE:	SWEPT PATH DRAWING	SHEET NO:
DRAWING NAME:	Route Survey	REV

DRAWN BY:	
DRAWN DATE:	
CHECKED BY:	

ARES PROJECT SERVICES PTY LTD - ABN: 45 643 587 115

Pinch Point

06

LEFT TURN
Bussell Hwy
& Sues Rd

ROUTE 1

The Sues Rd intersection is currently being upgraded as part of the Bussell Hwy duplication project, with a new roundabout to be installed. We do not have access to a scaled conceptual design drawing to analyse, but based on the current state of works, the turn should be relatively straightforward.

The extent of above-ground infrastructure at this new intersection, e.g. light poles, signage is not clear at this stage and a future review will be required to ensure the swept path of the blades does not impinge upon these assets.

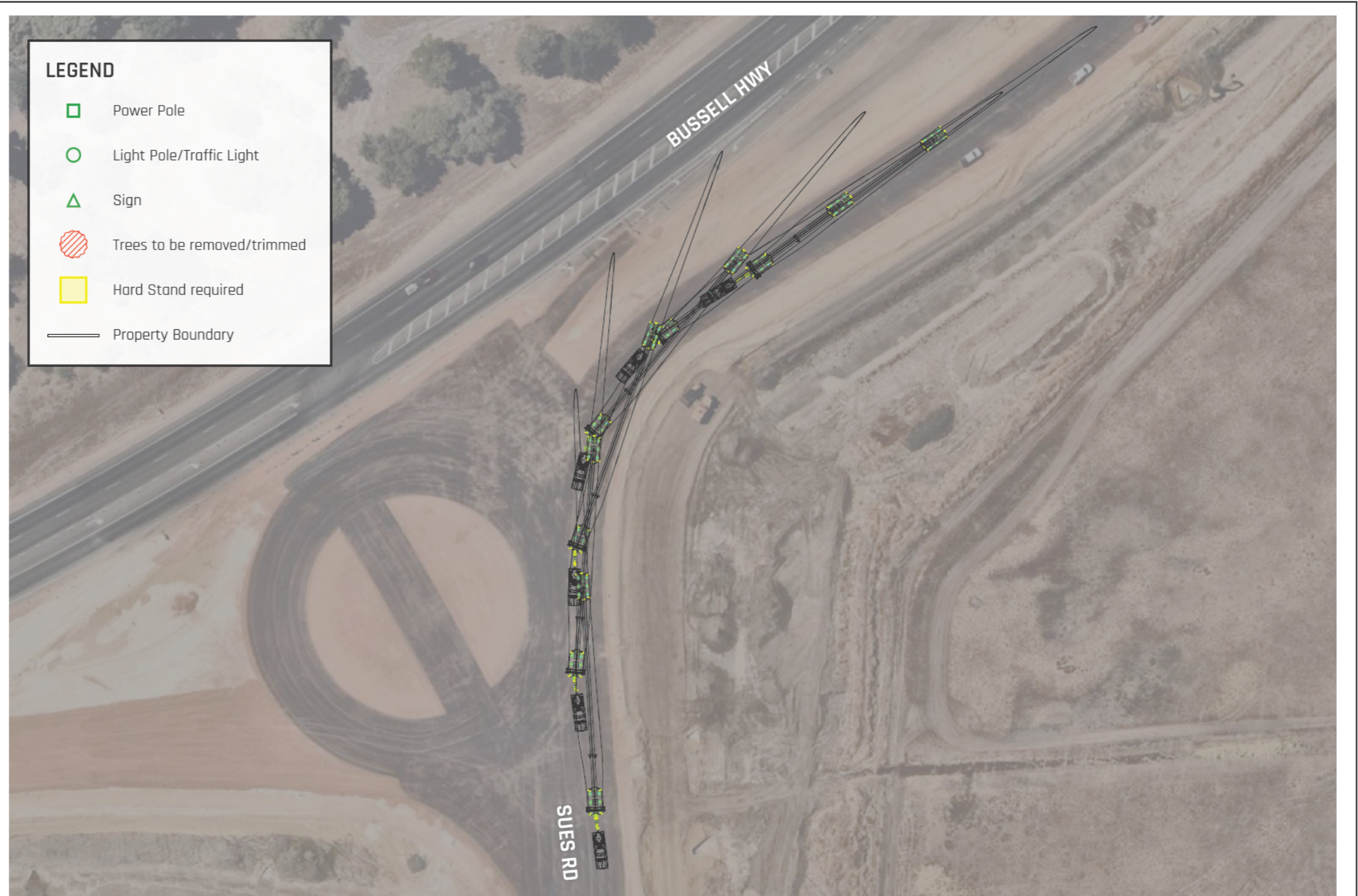

COPYRIGHT 2023 THE CONTENTS OF THIS DRAWING REMAINS THE PROPERTY OF ARES PROJECT SERVICES PTY LTD. NO CONTENTS MAY NOT BE COPIED OR REPRODUCED UNLESS AUTHORIZATION HAS BEEN PREVIOUSLY GIVEN, IN WRITING FROM ARES PROJECT SERVICES PTY LTD. THE CONTENTS OF THIS DRAWING ARE FOR THE PURPOSE OF TRANSPORT PLANNING, AND / OR TRANSPORT PROPOSAL. ALL DRAWINGS ARE TO BE USED AS A GUIDELINE ONLY. DRAWING NOTES: ALL DIMENSIONS ARE IN mm UNLESS NOTED OTHERWISE (UNO) ALL WEIGHTS ARE IN t (METRIC TONNES) UNO ALL DETAILS ARE PROVISIONAL AND SUBJECT TO CONFIRMATION LASHINGS CALCULATIONS AS PER RESTRAINT GUIDELINES	 www.aresgroup.com.au	CUSTOMER: SynergyRED	SIZE:
		PROJECT: Beenup WF	SCALE NTS
	DRAWN BY:	DRAWING TITLE: SWEPT PATH DRAWING	SHEET NO:
	DRAWN DATE:	DRAWING NAME: Route Survey	REV
	CHECKED BY:	ARES PROJECT SERVICES PTY LTD - ABN: 45 643 587 115	

Pinch Point

07

RIGHT TURN
Sues Rd &
Brockman Hwy

ROUTE 1

The right turn onto Brockman Hwy is in a forested area, and the sheer length of the blades will mean that to avoid tree trimming and possibly removal, a large amount of hard stand is required on the inside and outside of the corner.

The combination will stay well clear of a protected tree to the south of the intersection.

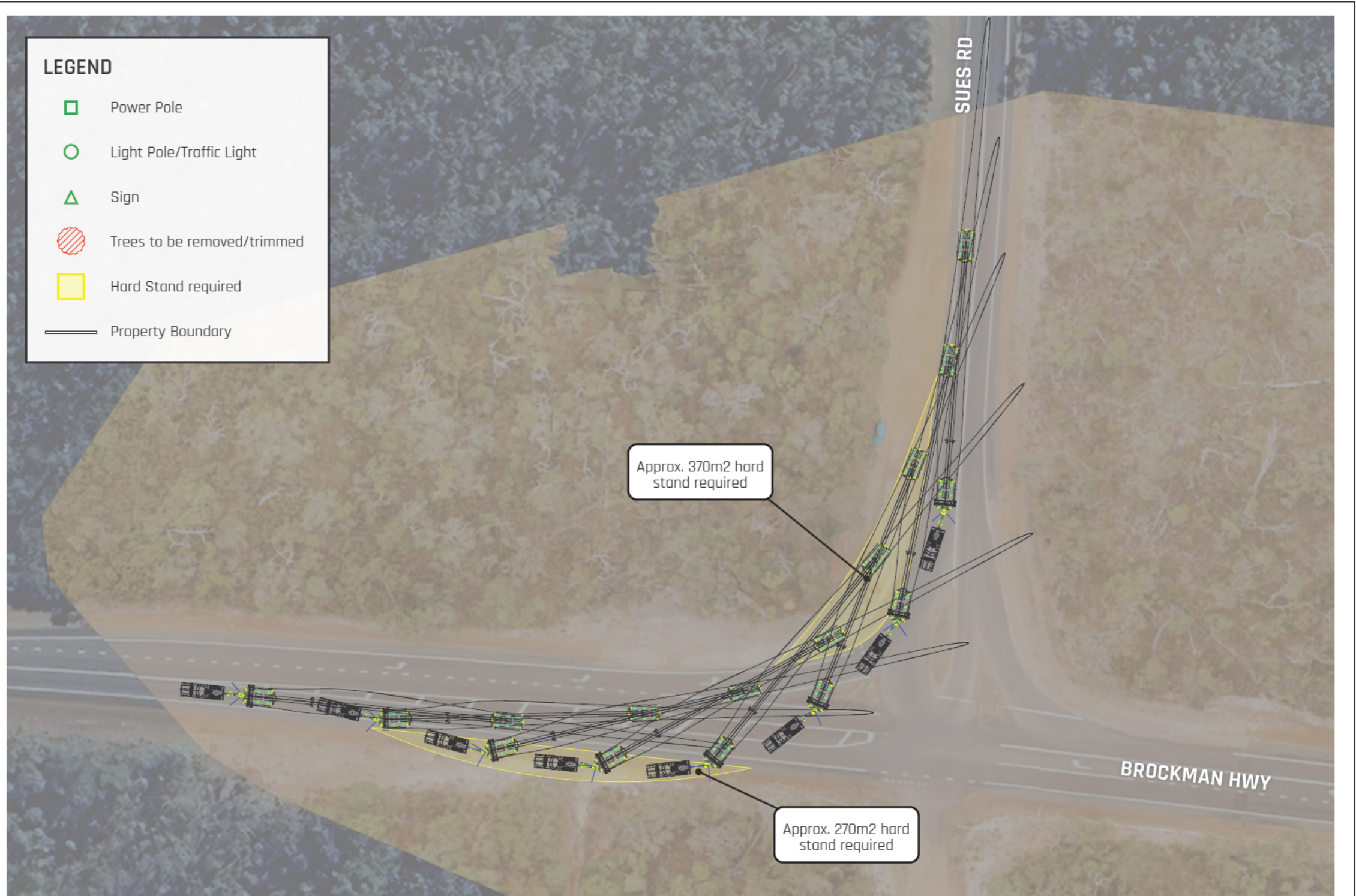

<p>COPYRIGHT 2023</p> <p>THE CONTENTS OF THIS DRAWING REMAINS THE PROPERTY OF ARES PROJECT SERVICES PTY LTD. NO CONTENTS MAY NOT BE COPIED OR REPRODUCED UNLESS AUTHORIZATION HAS BEEN PREVIOUSLY GIVEN, IN WRITING FROM ARES PROJECT SERVICES PTY LTD. THE CONTENTS OF THIS DRAWING ARE FOR THE PURPOSE OF TRANSPORT PLANNING, AND / OR TRANSPORT PROPOSAL. ALL DRAWINGS ARE TO BE USED AS A GUIDELINE ONLY.</p> <p>DRAWING NOTES:</p> <p>ALL DIMENSIONS ARE IN mm UNLESS NOTED OTHERWISE (UNO) ALL WEIGHTS ARE IN t (METRIC TONNES) UNO ALL DETAILS ARE PROVISIONAL AND SUBJECT TO CONFIRMATION LASHINGS CALCULATIONS AS PER RESTRAINT GUIDELINES</p>		CUSTOMER:	SynergyRED	SIZE:
		PROJECT:	Beenup WF	SCALE NTS
	DRAWN BY:	DRAWING TITLE:	SWEPT PATH DRAWING	SHEET NO:
	DRAWN DATE:	DRAWING NAME:	Route Survey	REV
	CHECKED BY:	ARES PROJECT SERVICES PTY LTD - ABN: 45 643 587 115		

Pinch Point

08

LEFT TURN
Brockman Hwy
& Scott River Rd

ROUTE 1

This intersection is quite wide, allowing the blade to stay clear of all trees. The extent of modifications will be limited to hard stand material on the inside of the corner, and one sign to be made removeable.

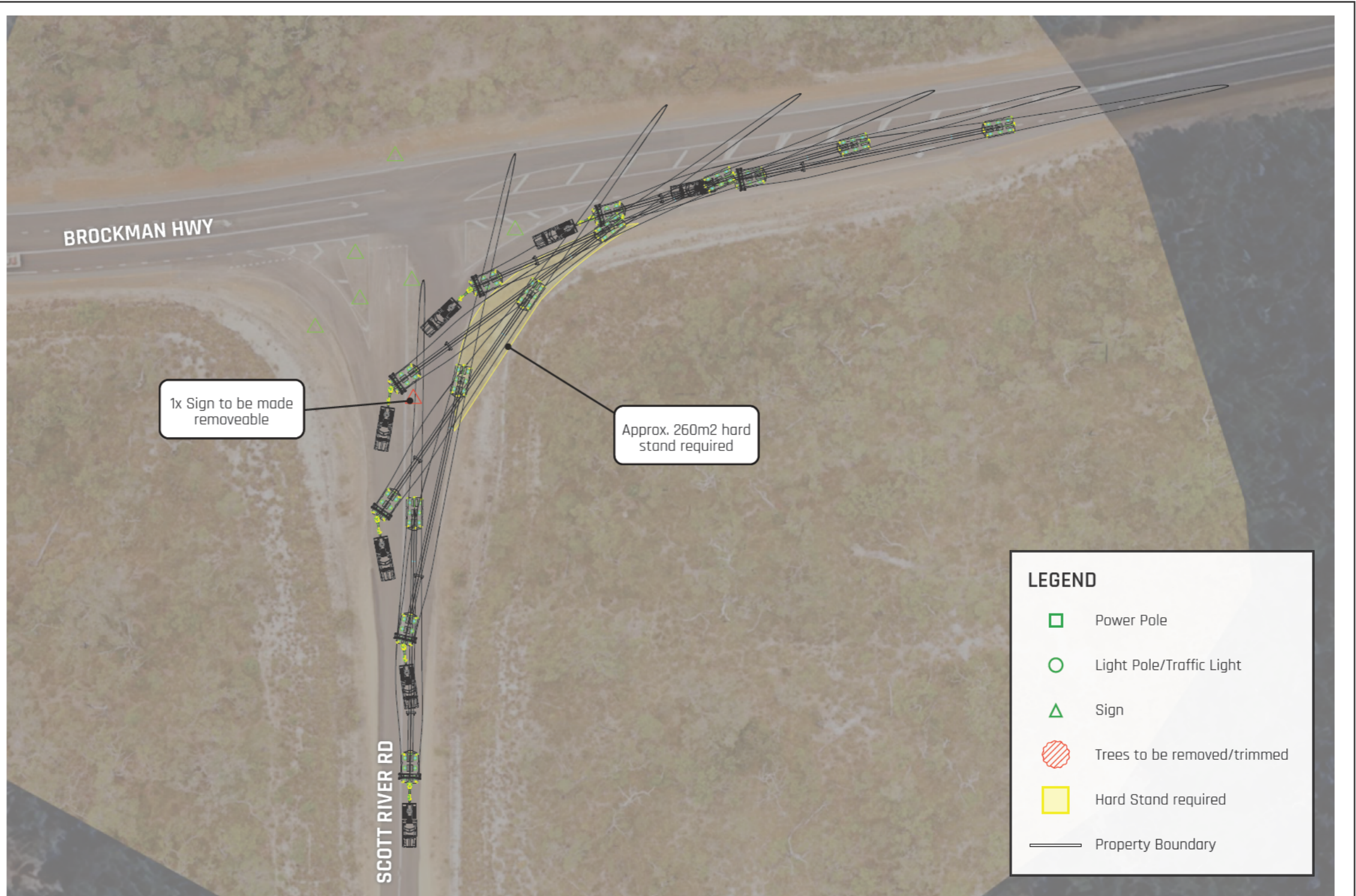

LEGEND

- Power Pole
- Light Pole/Traffic Light
- △ Sign
- ⊘ Trees to be removed/trimmed
- Hard Stand required
- Property Boundary

<p>COPYRIGHT 2023</p> <p>THE CONTENTS OF THIS DRAWING REMAINS THE PROPERTY OF ARES PROJECT SERVICES PTY LTD. NO CONTENTS MAY NOT BE COPIED OR REPRODUCED UNLESS AUTHORIZATION HAS BEEN PREVIOUSLY GIVEN, IN WRITING FROM ARES PROJECT SERVICES PTY LTD. THE CONTENTS OF THIS DRAWING ARE FOR THE PURPOSE OF TRANSPORT PLANNING, AND / OR TRANSPORT PROPOSAL. ALL DRAWINGS ARE TO BE USED AS A GUIDELINE ONLY.</p> <p>DRAWING NOTES:</p> <p>ALL DIMENSIONS ARE IN mm UNLESS NOTED OTHERWISE (UNO) ALL WEIGHTS ARE IN t (METRIC TONNES) UNO ALL DETAILS ARE PROVISIONAL AND SUBJECT TO CONFIRMATION LASHINGS CALCULATIONS AS PER RESTRAINT GUIDELINES</p>		CUSTOMER: SynergyRED	SIZE:
		PROJECT: Beenup WF	SCALE NTS
	DRAWN BY:	DRAWING TITLE: SWEPT PATH DRAWING	SHEET NO:
	DRAWN DATE:	DRAWING NAME: Route Survey	REV
	CHECKED BY:	ARES PROJECT SERVICES PTY LTD - ABN: 45 643 587 115	



03

Site Entrance Assessment



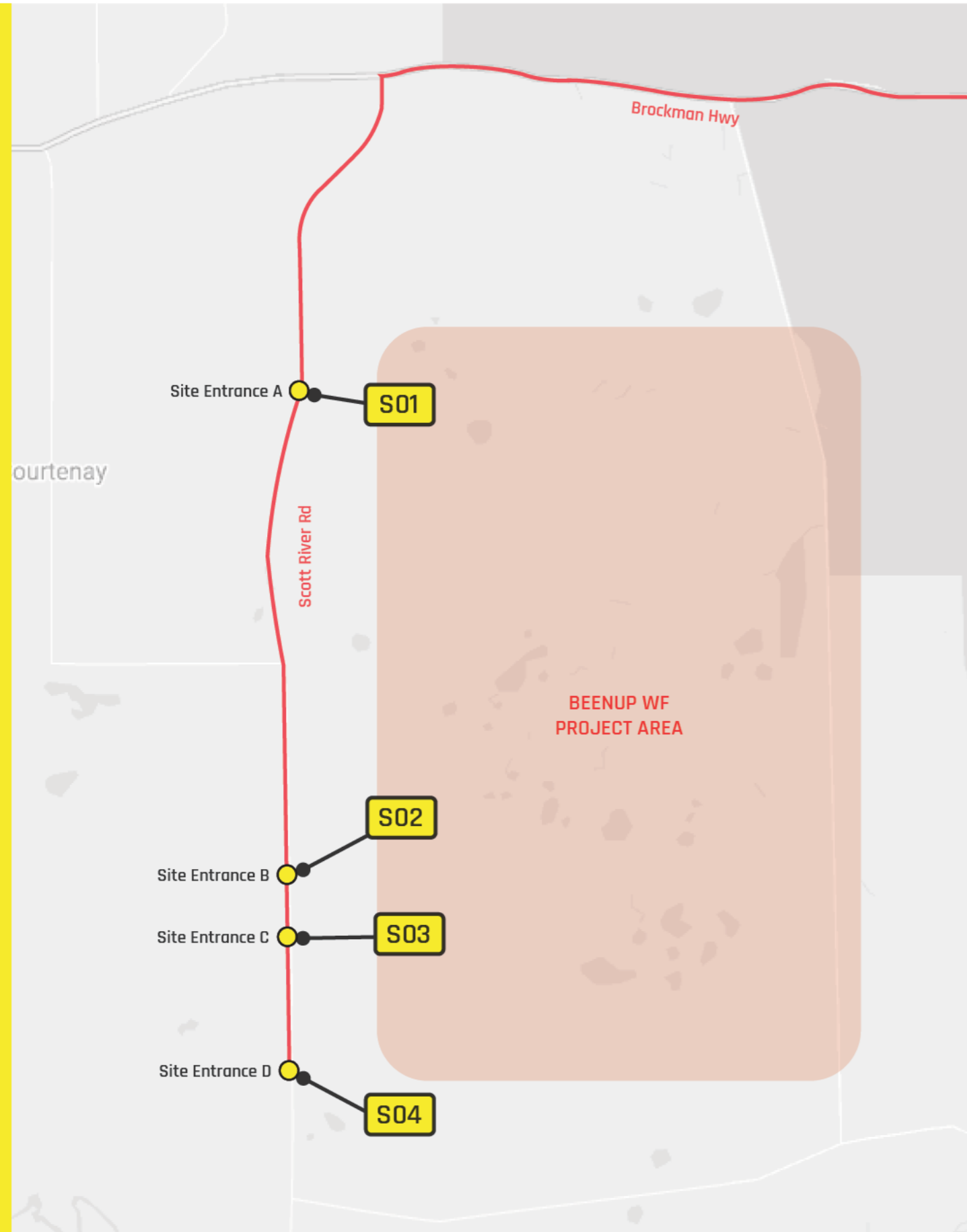

Beenup WF Site Entrances

There are four proposed site entrances to the Beenup Wind Farm project area, all accessed by turning left off Scott River Rd. From north to south, they are:

- Site Entrance A: existing farm access track
- Site Entrance B: clear area adjacent to fenceline
- Site Entrance C: clear area adjacent to fenceline
- Site Entrance D: rough existing track

ARES performed a swept path analysis on each proposed site entrance to determine the potential impacts to vegetation and land use. These are presented in the following pages and are only intended to give an idea of the clear area required for blades to make the turn into site. Formal civil design of the site entrances will be done by others.

Site Entrance A



Site Entrance B



Site Entrance C



Site Entrance D



Pinch Point

S01

LEFT TURN
Proposed Site
Entrance A

ROUTE 1

Site Entrance A is situated at an existing farm access track. The area is forested and getting blades into this entry point without tree clearing will require a new turn-in track made of hard stand material.

The existing livestock pen and a portion of existing fencing will need to be demolished and replaced with an access gate. This will require the landowner's permission.

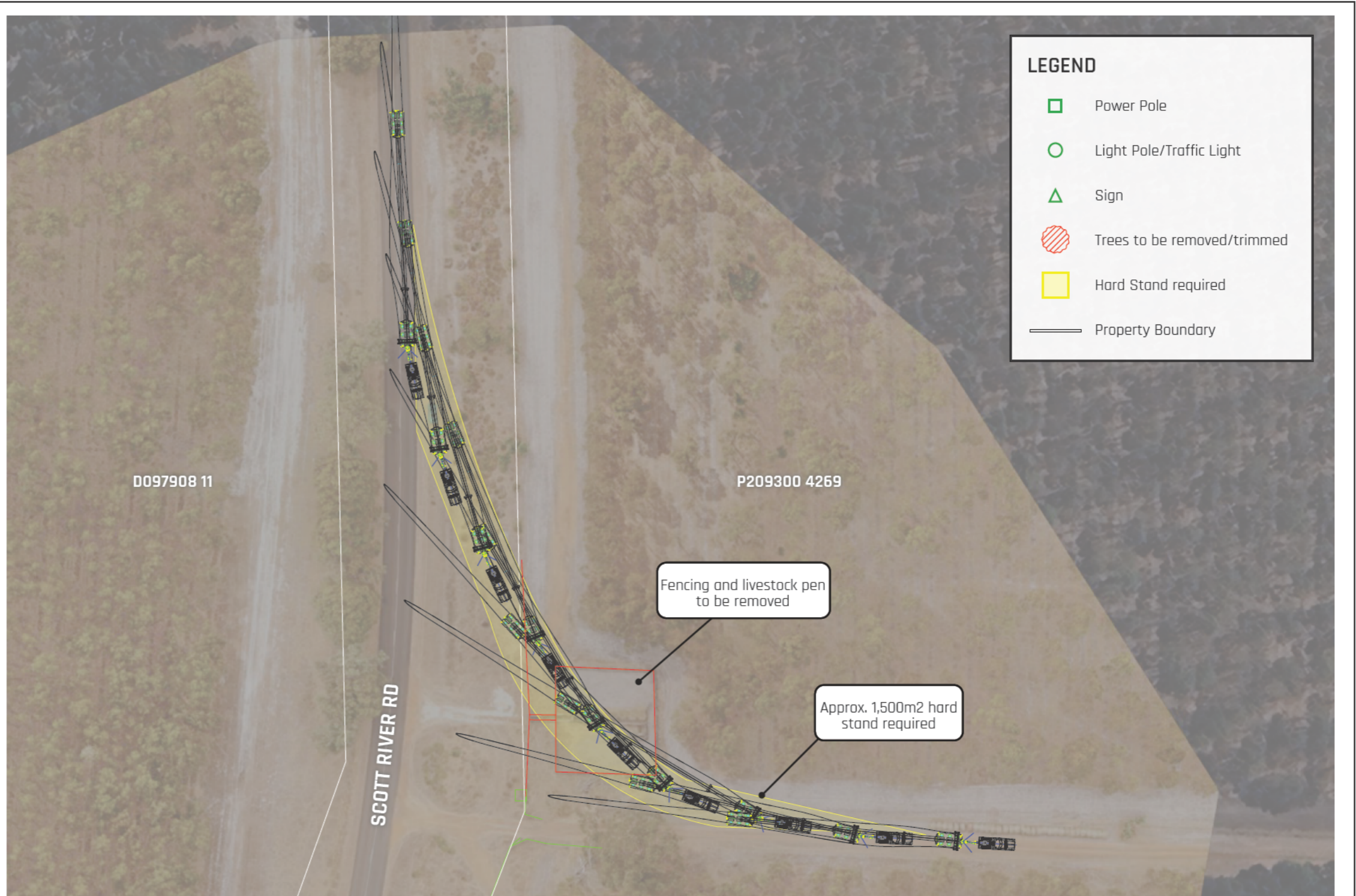

LEGEND

- Power Pole
- Light Pole/Traffic Light
- △ Sign
- ▨ Trees to be removed/trimmed
- Hard Stand required
- Property Boundary

<p>COPYRIGHT 2023</p> <p>THE CONTENTS OF THIS DRAWING REMAINS THE PROPERTY OF ARES PROJECT SERVICES PTY LTD. NO CONTENTS MAY NOT BE COPIED OR REPRODUCED UNLESS AUTHORIZATION HAS BEEN PREVIOUSLY GIVEN, IN WRITING FROM ARES PROJECT SERVICES PTY LTD. THE CONTENTS OF THIS DRAWING ARE FOR THE PURPOSE OF TRANSPORT PLANNING, AND / OR TRANSPORT PROPOSAL. ALL DRAWINGS ARE TO BE USED AS A GUIDELINE ONLY.</p> <p>DRAWING NOTES:</p> <p>ALL DIMENSIONS ARE IN mm UNLESS NOTED OTHERWISE (UNO) ALL WEIGHTS ARE IN t (METRIC TONNES) UNO ALL DETAILS ARE PROVISIONAL AND SUBJECT TO CONFIRMATION LASHINGS CALCULATIONS AS PER RESTRAINT GUIDELINES</p>		CUSTOMER: SynergyRED	SIZE:
		PROJECT: Beenup WF	SCALE NTS
		DRAWING TITLE: SWEPT PATH DRAWING	SHEET NO:
		DRAWING NAME: Route Survey	REV
	DRAWN BY: DRAWN DATE: CHECKED BY:	ARES PROJECT SERVICES PTY LTD - ABN: 45 643 587 115	

Pinch Point

S02

LEFT TURN
Proposed Site
Entrance B

ROUTE 1

Site Entrance B is at a relatively clear area of farmland. To stay clear of the trees on the west, blades will have to start turning in early. A section of existing fencing will need to be removed, and one small shrub will need to be cleared on the east side of Scott River Rd.

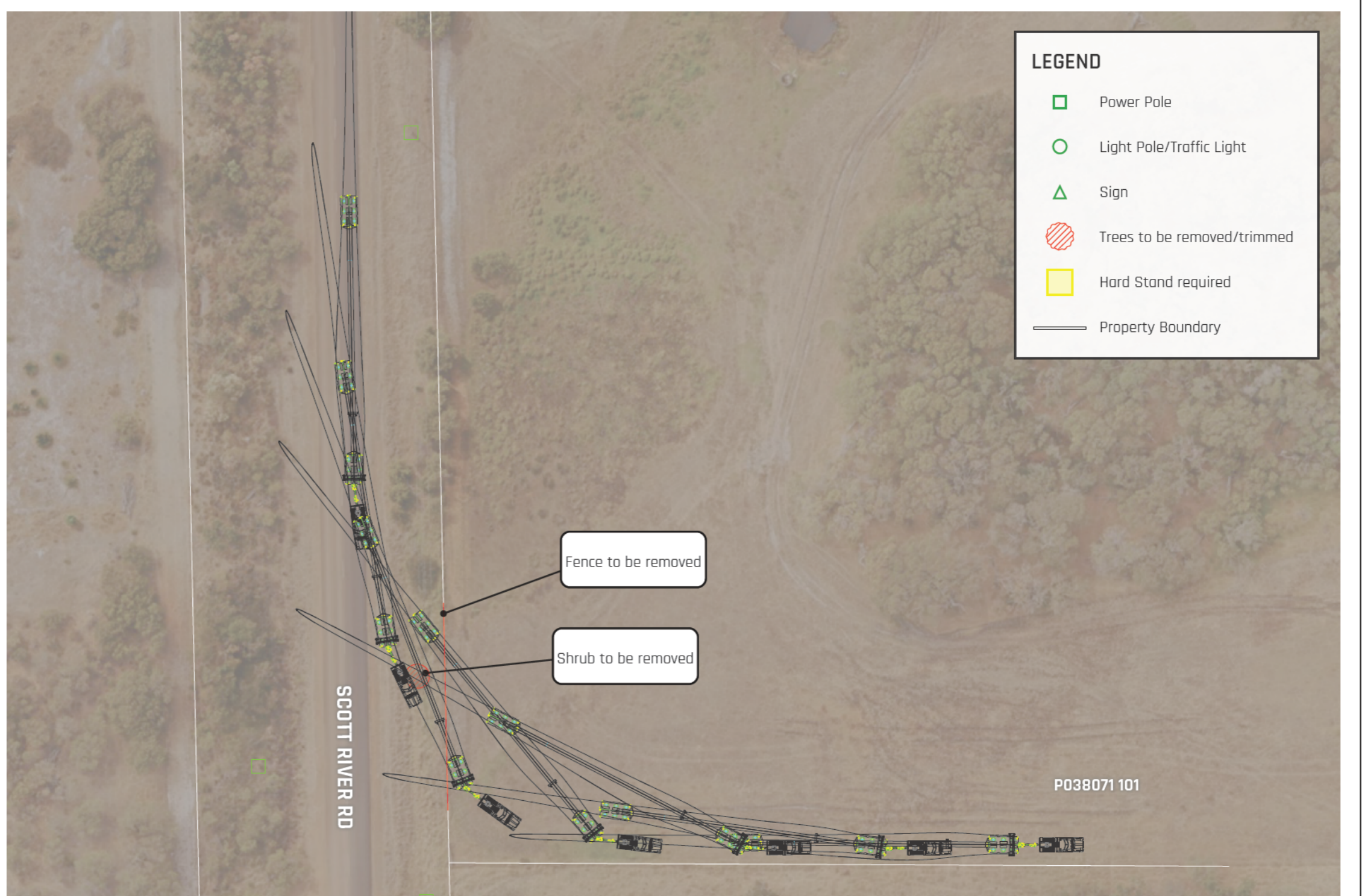

<p>COPYRIGHT 2023</p> <p>THE CONTENTS OF THIS DRAWING REMAINS THE PROPERTY OF ARES PROJECT SERVICES PTY LTD. NO CONTENTS MAY NOT BE COPIED OR REPRODUCED UNLESS AUTHORIZATION HAS BEEN PREVIOUSLY GIVEN, IN WRITING FROM ARES PROJECT SERVICES PTY LTD. THE CONTENTS OF THIS DRAWING ARE FOR THE PURPOSE OF TRANSPORT PLANNING, AND / OR TRANSPORT PROPOSAL. ALL DRAWINGS ARE TO BE USED AS A GUIDELINE ONLY.</p> <p>DRAWING NOTES:</p> <p>ALL DIMENSIONS ARE IN mm UNLESS NOTED OTHERWISE (UNO) ALL WEIGHTS ARE IN t (METRIC TONNES) UNO ALL DETAILS ARE PROVISIONAL AND SUBJECT TO CONFIRMATION LASHINGS CALCULATIONS AS PER RESTRAINT GUIDELINES</p>		CUSTOMER:	SynergyRED	SIZE:
		PROJECT:	Beenup WF	SCALE NTS
	DRAWN BY: DRAWN DATE: CHECKED BY:	DRAWING TITLE:	SWEPT PATH DRAWING	SHEET NO:
		DRAWING NAME:	Route Survey	REV
ARES PROJECT SERVICES PTY LTD - ABN: 45 643 587 115				

Pinch Point

S03

LEFT TURN
Proposed Site
Entrance C

ROUTE 1

Site Entrance C is just south of Site Entrance B and has very similar characteristics. The blade can be kept clear of the trees on the west, and only the existing fence will need to be modified.

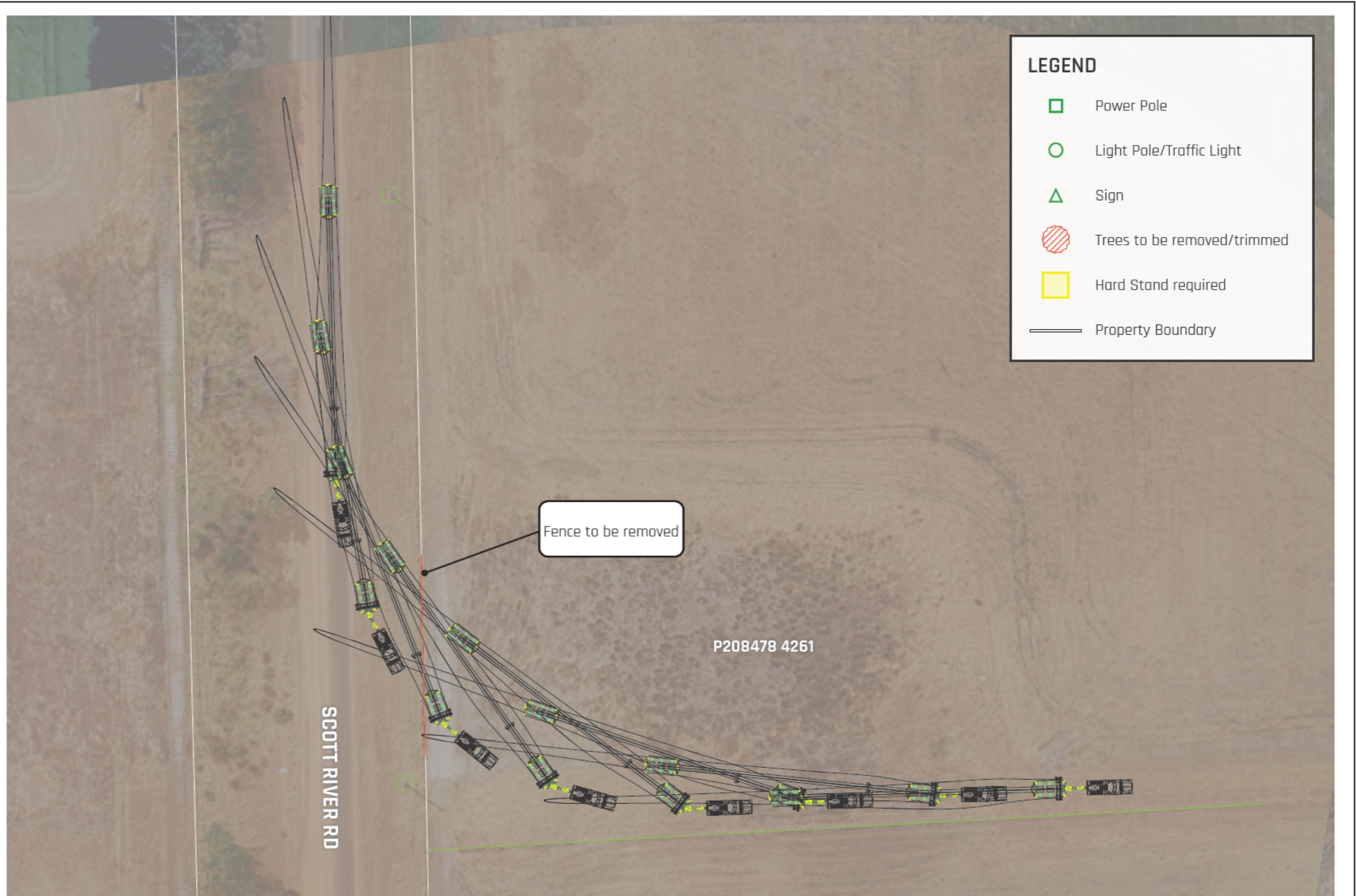

LEGEND

- Power Pole
- Light Pole/Traffic Light
- △ Sign
- ▨ Trees to be removed/trimmed
- Hard Stand required
- Property Boundary

COPYRIGHT 2023

THE CONTENTS OF THIS DRAWING REMAINS THE PROPERTY OF ARES PROJECT SERVICES PTY LTD. NO CONTENTS MAY NOT BE COPIED OR REPRODUCED UNLESS AUTHORIZATION HAS BEEN PREVIOUSLY GIVEN, IN WRITING FROM ARES PROJECT SERVICES PTY LTD. THE CONTENTS OF THIS DRAWING ARE FOR THE PURPOSE OF TRANSPORT PLANNING, AND / OR TRANSPORT PROPOSAL. ALL DRAWINGS ARE TO BE USED AS A GUIDELINE ONLY.

DRAWING NOTES:

ALL DIMENSIONS ARE IN mm UNLESS NOTED OTHERWISE (UNO) ALL WEIGHTS ARE IN t (METRIC TONNES) UNO ALL DETAILS ARE PROVISIONAL AND SUBJECT TO CONFIRMATION LASHINGS CALCULATIONS AS PER RESTRAINT GUIDELINES

 www.aresgroup.com.au	CUSTOMER:	SynergyRED	SIZE:
	PROJECT:	Beenup WF	SCALE NTS
	DRAWING TITLE:	SWEPT PATH DRAWING	SHEET NO:
	DRAWING NAME:	Route Survey	REV
DRAWN BY: DRAWN DATE: CHECKED BY:	ARES PROJECT SERVICES PTY LTD - ABN: 45 643 587 115		

Pinch Point

S04

LEFT TURN
Proposed Site
Entrance D

ROUTE 1

As for the previous two entrances, Site Entrance D is a relatively straightforward left turn in, but there is a tree on the west which cannot be avoided and will need to be removed. The majority of vegetation on the east of Scott River Rd can be avoided, with only one small shrub requiring clearing.

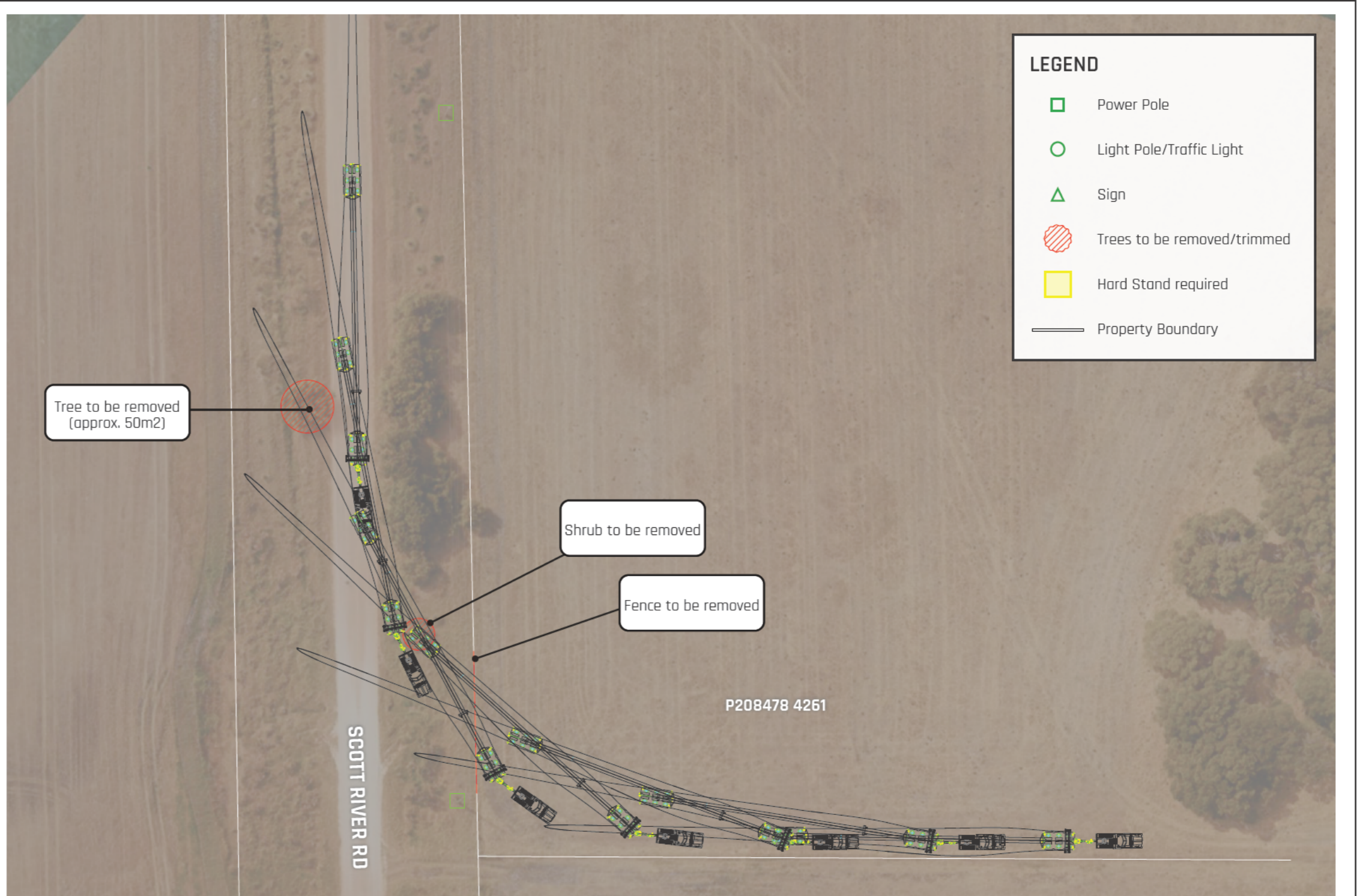

COPYRIGHT 2023

THE CONTENTS OF THIS DRAWING REMAINS THE PROPERTY OF ARES PROJECT SERVICES PTY LTD. NO CONTENTS MAY NOT BE COPIED OR REPRODUCED UNLESS AUTHORIZATION HAS BEEN PREVIOUSLY GIVEN, IN WRITING FROM ARES PROJECT SERVICES PTY LTD. THE CONTENTS OF THIS DRAWING ARE FOR THE PURPOSE OF TRANSPORT PLANNING, AND / OR TRANSPORT PROPOSAL. ALL DRAWINGS ARE TO BE USED AS A GUIDELINE ONLY.

DRAWING NOTES:

ALL DIMENSIONS ARE IN mm UNLESS NOTED OTHERWISE (UNO) ALL WEIGHTS ARE IN t (METRIC TONNES) UNO ALL DETAILS ARE PROVISIONAL AND SUBJECT TO CONFIRMATION LASHINGS CALCULATIONS AS PER RESTRAINT GUIDELINES

 www.aresgroup.com.au	CUSTOMER:	SynergyRED	SIZE:
	PROJECT:	Beenup WF	SCALE NTS
DRAWN BY:	DRAWING TITLE:	SWEPT PATH DRAWING	SHEET NO:
DRAWN DATE:	DRAWING NAME:	Route Survey	REV
CHECKED BY:	ARES PROJECT SERVICES PTY LTD - ABN: 45 643 587 115		



04

Conclusion

Conclusion

A brief outline of the report's major findings and any recommendations for actions.



...transport of OSOM components to Beenup WF is feasible.

Summary

Following our physical survey and analysis, ARES believe that transport of the oversize overmass (OSOM) components (including 90m blades) for the Beenup WF project from the **Port of Bunbury** is feasible with appropriate modifications made to the route as noted in this report.

There are no issues with using Bunbury as the Port of Import as it has a proven capacity for handling wind turbine cargo. Storage areas are sufficient to handle a project of this size.

One transport route was assessed - it is both the most direct and simplest route from Bunbury. There are no overhead obstructions and theoretically there is no limit on the tower size, although we have limited our assessment to 6.0m in diameter for this study. Power line lifting requirements will become significant with towers that are any larger.

The amount of modifications required to the route is relatively minor considering the size of blade and associated swept path under consideration. We have provided Summary of Road Modifications tables on the following page for convenient reference. Modifications on State roads will require approvals from Main Roads WA.

Four potential Site Entrances were assessed. Site Entrance A has significant vegetation clearing requirements, whilst the other three are in clearer areas, require less works and may be preferred for that reason.

Next Steps

To progress the OSOM transport scope further from here, the following steps are recommended:

- Early engagement with transport authorities (MRWA) and local councils (Shire of Augusta Margaret River) to obtain feedback and approval of proposed route, proposed modifications and any special conditions
- Early engagement of power authorities (Western Power) to perform a formal overhead asset survey for the route
- Early engagement with Southern Ports Bunbury regarding project timing, berth and storage area availability
- Selection of wind turbine model and hub height to allow detailed transportation analysis with actual components to be transported



Level Crossing Removal Project

A 125-ton, 25m-long precast concrete U-trough is unloaded at its destination after travelling through the heart of metropolitan Melbourne.

Summary of Road Modifications

The following table lists all required modifications to allow transport of components to take place.

Pinch Point	Road/Intersection	Modifications Required	Risk
01	Port Storage & Leschenault Dr	Temporary hardstand to be laid down on port land (approx. 320m ²)	Medium
02	Leschenault Dr & Estuary Dr	Temporary hardstand to be laid down (approx. 230m ²), 1x light pole to be relocated, some wire fencing to be removed	Medium
03	Estuary Dr & Koombana Dr	Temporary hardstand to be laid down (approx. 260m ²), 1x sign to be made removeable.	Medium
04	Eelup Rotary	1x sign to be made removeable	Low
05	Robertson Dr & Bussell Hwy	6x signs to be made removeable	Low
06	Bussell Hwy & Sues Rd	Nil at this stage - pending completion of roundabout construction	Low
07	Sues Rd & Brockman Hwy	Temporary hardstand to be laid down (approx. 640m ²)	Medium
08	Brockman Hwy & Scott River Rd	Temporary hardstand to be laid down (approx. 260m ²), 1x sign to be made removeable	Medium
S01	Site Entrance A	Temporary hardstand to be laid down (approx. 1,500m ²), live-stock pen and fence to be removed	High
S02	Site Entrance B	Shrub removal required, existing fence to be removed/modified	Low
S03	Site Entrance C	Existing fence to be removed/modified	Low
S04	Site Entrance D	1x tree to be removed (approx. 50m ²), shrub to be removed, existing fence to be removed/modified	Medium

PAGE INTENTIONALLY LEFT BLANK



Ares Project Services PTY LTD

L105, 480 StKilda Rd
Melbourne VIC, 3004

P: 1300 243 289

F: +61 3 8560 7020

E: enquiries@aresgroup.com.au

W: www.aresgroup.com.au

