

**R1036 Rev 0**

**July 2018**

**Shire of Exmouth**

**Tantabiddi Boat Launching Facility  
Investigation**

marinas

boat harbours

canals

breakwaters

jetties

seawalls

dredging

reclamation

climate change

waves

currents

tides

flood levels

water quality

siltation

erosion

rivers

beaches

estuaries

# m p rogers & associates pl

creating better coasts and ports

Suite 1, 128 Main Street, Osborne Park, WA 6017

p: +618 9254 6600

e: [admin@coastsandports.com.au](mailto:admin@coastsandports.com.au)

w: [www.coastsandports.com.au](http://www.coastsandports.com.au)

## K1514, Report R1036 Rev 0

### Record of Document Revisions

Rev	Purpose of Document	Prepared	Reviewed	Approved	Date
A	Draft for MRA & Client review	T Harding	P Doust	P Doust	19/06/18
0	Issued for Client use	T Harding	P Doust	P Doust	18/07/18

Form 035 18/06/2013

### Limitations of this Document

This document has been prepared for use by the Client in accordance with the agreement between the Client and M P Rogers & Associates Pty Ltd. This agreement includes constraints on the scope, budget and time available for the services. The consulting services and this document have been completed with the degree of skill, care and diligence normally exercised by members of the engineering profession performing services of a similar nature. No other warranty, expressed or implied, is made as to the accuracy of the data and professional advice included. This document has not been prepared for use by parties other than the Client and its consulting advisers. It may not contain sufficient information for the purposes of other parties or for other uses.

M P Rogers & Associates takes no responsibility for the completeness or form of any subsequent copies of this document. Copying this document without the permission of the Client or M P Rogers & Associates Pty Ltd is not permitted.

## Executive Summary

The Shire of Exmouth (Shire) engaged specialist coastal and port engineers, M P Rogers and Associates Pty Ltd (MRA), to investigate the Tantabiddi Boat Launching Facility (Facility).

The aim of the investigation included the following:

- Understand the current usage of the Facility.
- Estimate future use trends.
- Determine required infrastructure to handle the future usage trends.

The full scope of the investigation is presented within the report.

To understand the current and future usage of the Facility the following data was analysed:

- Online Boat Users Surveys.
- Traffic Counter Data.
- Whale Shark Tour Participants Data.
- Boat Registration Data and Population Statistics and trends.

A brief summary of the results of the current Facility usage assessment is provided below:

- The estimated overall percentage usage of the Facility was attributed to approximately 50% commercial and 50% recreational.
- Exmouth currently has 246 registered vessels per 1,000 residents which one of the highest vessel ownership rates in Western Australia.
- The peak usage season of the Facility was identified as between March and October.
- The busiest periods of the day at the Facility are between 6am to 10am (typically for launching vessels) and 2pm and 6pm (for retrieval of vessels).
- Currently, on peak days during the peak season approximately 100 to 125 trailered vessels, 250 to 300 vehicles and 500 to 600 passengers utilise the Facility.
- Currently, on average days during the peak season approximately 30 to 40 trailered vessels, 150 to 200 vehicles and 200 to 300 passengers utilise the Facility.
- Over 1,000 responses were received for the recreational user survey, demonstrating a large interest in the facility from local, national and international users.
  - 29% of respondents identified themselves as residents and 71% as visitors.
  - 95% of the respondents utilise the Facility for fishing activities.
  - 90% of the respondents strongly supported or supported and upgrade of the Facility.

- The majority of commercial operators that are licenced to use to the Facility responded to the commercial user survey.
  - The majority of commercial tours are focused on fishing and whale shark snorkelling/viewing activities.
  - 90% of the respondents strongly supported or supported and upgrade of the Facility.

The results from the boat user surveys highlighted the key issues with the existing Facility which included the following:

- The facility has poor separation of recreational and commercial users leading to conflicts.
- Lack of instructive signage.
- Alignment of boat ramps in regard to wind and wave conditions.
- Limited shade structures.
- General safety of the Facility in regard to wave climate.

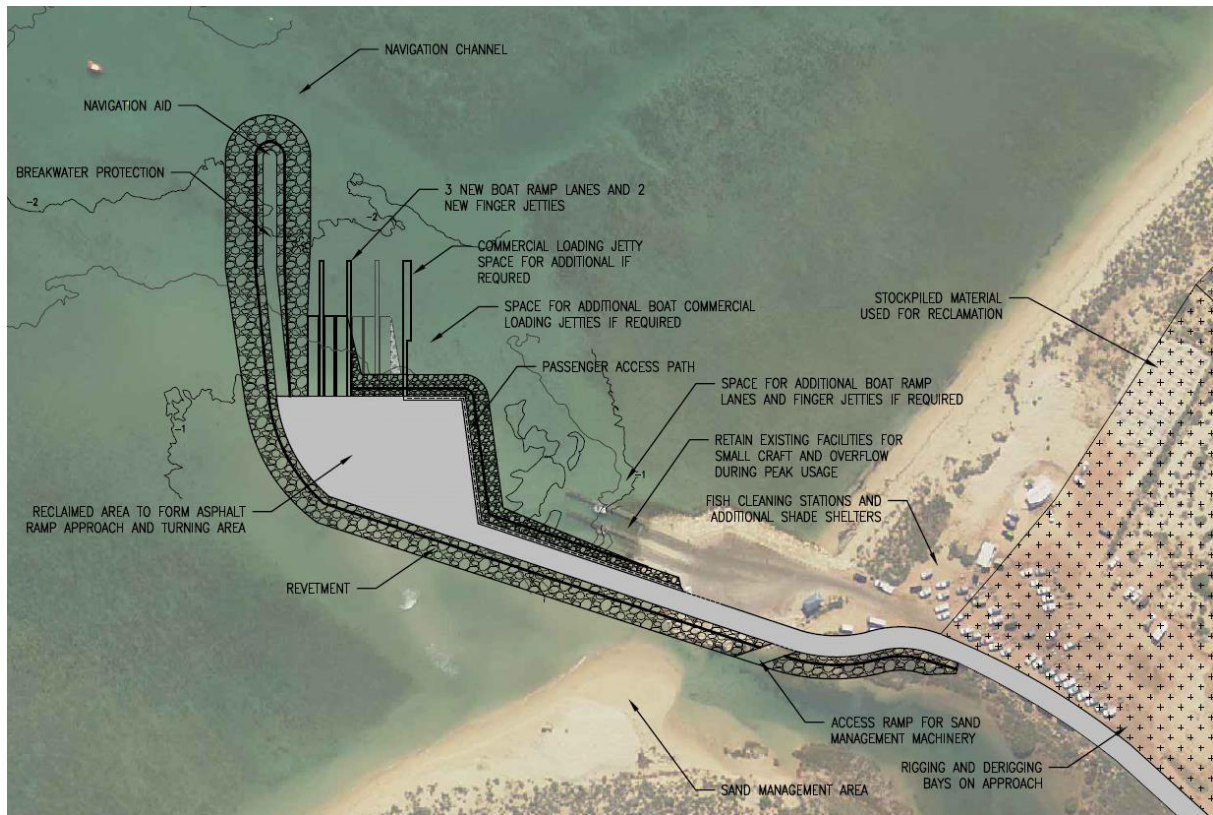
Key requirements for an upgraded Facility included the following:

- Additional finger jetty/jetties for commercial loading and unloading of equipment/passengers.
- Additional ramps and finger jetties.
- Separation of commercial and recreational users through designated ramp lanes and drop off only jetty/jetties during peak commercial times.
- Include fish cleaning stations.
- Protection from the wave conditions.
- Increased parking areas.
- Improved waste management.
- Deeper approach navigational channels that are regularly dredged.

The assessment of the current Facility usage, projected residential and visitor population and vessel usage trends resulted in the following infrastructure recommendations:

- 8 ramp lanes and associated finger jetties are recommended by the end of the 2038.
- Given the need for separation of commercial and recreational activity, 2 commercial loading jetties are recommended by the end of 2038.
- Approximately 6 to 8ha of land will be required by 2038 for car, bus and trailer parking and rigging/derigging areas.

The ultimate recommended solution for an upgraded Facility at the existing site is shown in the following figure. This has been developed to address the key issues with the existing facility and provide for the likely increase in usage to 2038.



This option is likely to cost in the order \$19.3 million. There are a number of intermediate options including improvements to the existing facility or staging the above works to match with the level of demand and funding opportunities. For example, as a first stage the breakwater protection could be installed with 2 additional ramp lanes and then more ramps could be added in the future. All of these options are likely to interrupt the longshore sediment transport and ongoing management of this sand will be required.

Given the numerous issues identified with the location of the existing site, namely the adjacent Tantabiddi Creek and its associated siltation management issues, a Facility at an alternative site should also be further investigated.

The designs presented in the report are at concept level and further work and investigations are required for the upgrade of the Facility to proceed. These include the following:

- Detailed assessment of waves and sediment transport.
- Preliminary and detailed design.
- Approvals, including environmental and planning.

Based on discussions with the Shire, in recent history, the Shire has been operating at a loss and the ongoing funding of the Facility is unsustainable. The forecasted average annual ongoing costs for the existing Facility and the proposed Facility are in the order of \$405,000 and \$538,000

per annum respectively. These costs are unable to be met by the Shire and it is likely that the existing Facility would fall into a state of disrepair. This could result in the eventual closure of the Tantabiddi Boat Launching Facility.

Given that approximately 50% of the current usage of the Facility can be attributed to the local commercial tourism industry that caters for local, national and international tourists, it is unreasonable for the Shire (and local rate payers that only attribute to a low percentage of the current usage of the Facility) to continue to fund the ongoing costs of the Facility. On this basis, it is recommended that the Shire seeks financial assistance from the State and Federal level for the ongoing costs of the existing Facility and the capital and ongoing costs of the proposed Facility.

A user pays funding arrangement for the ongoing maintenance and management of the Facility was investigated and may be a part of the solution to the Shire's current expenditure issues.

## Table of Contents

Executive Summary	ii
1. Introduction	1
2. Background Information	3
2.1 Boat Ramp History	3
2.2 Historical Facility Management	3
3. Existing Site Conditions	5
3.1 Site Setting	5
3.2 Site Inspection	12
4. Facility Usage Assessment	18
4.1 Online Boat User Surveys	19
4.2 Traffic Counter Assessment	43
4.3 Whale Shark Tour Participants	50
4.4 Recreational Boat Registration Data & Trends	51
4.5 Data Assessment Summary	54
5. Future Demand & Requirements	56
5.1 Projections	56
6. Concept Options	65
6.1 Existing Site	65
6.2 Alternative Site	73
7. Potential Funding Streams	75
7.1 Shire's Situation	75
7.2 Other Government Contributions	75
7.3 User-Pays	75
8. Conclusions & Recommendations	79
9. References	80
10. Appendices	82
Appendix A Facility Improvement Investigation Drawings (DPI 2004)	83
Appendix B Existing Facility Drawings (URS 2012)	84
Appendix C Existing Facility Dredging Design Drawings (URS 2015)	85
Appendix D Tantabiddi Submergence Curve (DoT 2012)	86
Appendix E Long Term Expansion & Realignment Solution Sketch	87

## Table of Figures

Figure 1.1	Facility Locality	1
Figure 2.1	Aerial Photographs of Facility's Recent History	3
Figure 2.2	Revised Dredged Areas (URS 2015)	4
Figure 3.1	Geological Survey of Western Australia (DMP 1978 via DMIRS, 2017)	6
Figure 3.2	Swell Waves Reaching the Site	7
Figure 3.3	Nearshore Bathymetry (extract from DoT Chart WA900)	8
Figure 3.4	Locations of Water Level Data	9
Figure 3.5	Indicative Sediment Transport Pathways	11
Figure 3.6	Photographs of the Facility	12
Figure 3.7	Photographs of the Facility Carpark	15
Figure 3.8	Shire's Maintenance Vehicle & Waste Management Trailer	17
Figure 4.1	Online Survey Design Flow Process	19
Figure 4.2	Number of Respondents by Residency Location	20
Figure 4.3	Number of Respondents by WA Region	21
Figure 4.4	Loading and Unloading of Passengers from Northern Jetty	35
Figure 4.5	Traffic Counter Locations	43
Figure 4.6	DBCA Data – Number of Vehicles Entering Facility Per Day	44
Figure 4.7	MRA Data – Number of Vehicles Entering Boat Ramp Per Day	45
Figure 4.8	Difference Between Vehicle Counts (MRA – DBCA Data)	45
Figure 4.9	MRA Data – Number of Vehicles Entering Boat Ramp Per Hour (16 April 2018)	47
Figure 4.10	DBCA Data – Number of Vehicles Entering Facility Per Hour (16 April 2018)	47
Figure 4.11	Total Number of Vehicles Entering the Facility Per Month	48
Figure 4.12	Average Number of Vehicles & Visits – 2011 to 2017 (DBCA, 2017)	49
Figure 4.13	Number of Whale Shark Tour Participants (DBCA 2017)	50
Figure 4.14	Exmouth Region (ABS 2018)	51
Figure 4.15	Historical Population	52
Figure 4.16	Registered Vessels	52

Figure 4.17	Vessel Ownership Rates	53
Figure 5.1	Projected Population – Western Australia	57
Figure 5.2	Projected Population – Exmouth Residents	57
Figure 5.3	Projected Population – Exmouth Visitors	58
Figure 5.4	Vessel Ownership Rate Projections – Exmouth	59
Figure 5.5	Exmouth Projected Registered Vessels – Aspirational Growth	60
Figure 5.6	Exmouth Projected Registered Vessels – High Growth	60
Figure 5.7	Exmouth Visitor Projected Vessel Availability Rate	62
Figure 5.8	Exmouth Visitor Projected Peak Day Vessels – ‘4-year Growth’	62
Figure 5.9	Exmouth Visitor Projected Peak Day Vessels – ‘2-year Growth’	63
Figure 6.1	Recommended Solution – Expansion & Realignment	68
Figure 6.2	Potential Alternative Sites	73

## Table of Tables

Table 3.1	Tantabiddi Tidal Planes (DoT 2006)	10
Table 3.2a	Facility Defects	13
Table 3.2b	Facility Defects (Cont.)	14
Table 3.3	Vehicle Count During Inspection	16
Table 4.1	Commercial Car-park Usage	38
Table 4.2	Traffic Counter Data	43
Table 4.3	Vehicle Estimates on 16 April 2018	48
Table 4.4	Historic Vessel Ownership Rates – Other Regions	54
Table 4.5	Summary of Current Facility Usage in 2018	54
Table 5.1	Projected Annual Population Growth Rates	56
Table 5.2	Historic and Predicted Vessel Ownership Rates – Other Regions	59
Table 5.3	Vessel Usage Assumptions – Residents	61
Table 5.4	Vessel Usage & Ramp Requirements – Aspirational & 4-year Growth 64	
Table 5.5	Vessel Usage & Ramp Requirements – High & 2-year Growth	64
Table 6.1	10 Year Maintenance & Monitoring Cost Estimate – Existing Facility 67	
Table 6.2	Concept Capital Construction Cost Estimate	70
Table 6.3	20 Year Maintenance & Monitoring Cost Estimate – Proposed Facility 71	
Table 6.4	Staged Infrastructure Timing	72
Table 7.1	Estimated Users in 2017	77
Table 7.2	User-Pays Estimates for Existing Facility (Based on Current User Distribution and Usage)	77

## 1. Introduction

The Tantabiddi Boat Launching Facility (Facility) is located on the western side of the North West Cape, near Exmouth in Western Australia. It provides important access for boat users to the Ningaloo Reef and the adjacent coastal waters. The Facility is currently managed by the Shire of Exmouth (Shire). The location of the Facility is shown in the following figure.



**Figure 1.1 Facility Locality**

The Facility was designed as a recreational facility, however, it is also used by commercial operators and government agencies. The use of the Facility by multiple user groups creates congestion and associated conflicts during peak use periods.

Historically, the Shire has been required to solely fund the significant management costs associated with the Facility. This is creating an unsustainable negative input on the Shire's finances.

This has led the Shire to engage specialist coastal engineers, M P Rogers & Associates Pty Ltd (MRA), to undertake an investigation of the Facility. The investigation has been funded by the Department of Transport's (DoT) Recreational Boating Facility Scheme (RBFS). The scope of this investigation included the following:

- Define the current Facility users and the future user demand.
- Define future onshore and offshore infrastructure development needs and identify development locations separating commercial and recreational activity.
- Categorize the statutory responsibilities of the Shire, the Department of Transport (DoT) and the Department of Biodiversity, Conservation and Attractions (DBCA) related to the provision of recreational and the commercial maritime facilities.

- Identify which Government agencies benefit from the recreational and commercial operations at the Facility.
- Assess the annual cost of maintaining and preserving the existing onshore and offshore Facility, dredging, natural storm and cyclone damage projections and the associated recovery costs to 2028.
- Define and calculate the development and statutory approval cost of the onshore and offshore Facility to meet future demand to 2038.
- Investigate implementation of user pay systems for commercial and recreational users with the recovery amount to be sufficient to offset the maintenance, preservation, storm and cyclone damage recovery works and the future capital expansion to 2038.

Further details including the methodology employed and the results of this investigation are outlined within this report.

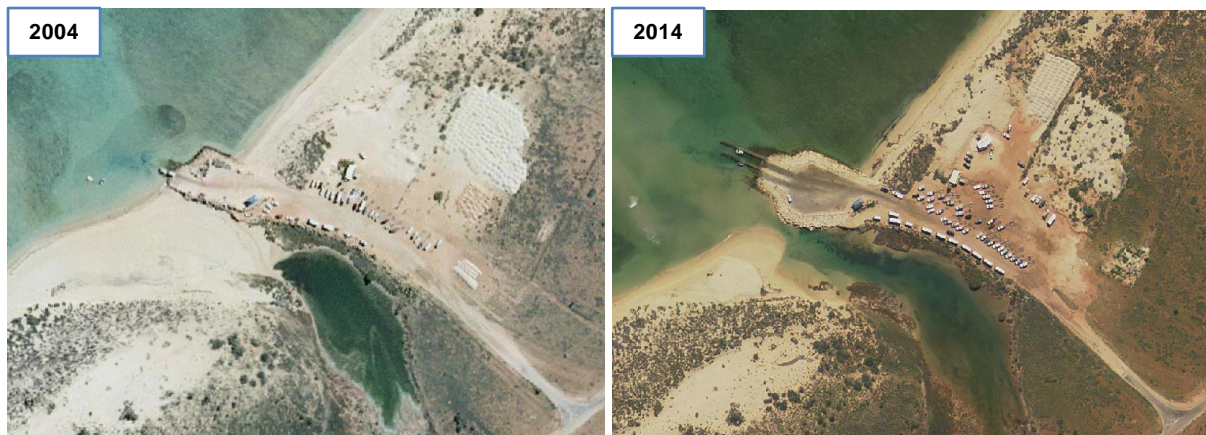
## 2. Background Information

### 2.1 Boat Ramp History

The original single lane boat ramp was constructed in the 1990s. The site is adjacent to the Tantabiddi Creek which provides a natural channel through the shallow reef extending along the shoreline.

In 2004, the Department of Planning and Infrastructure (DPI) investigated various options for upgrading the facility including offshore wave protection structures. The Drawings of these options are attached as Appendix A.

In 2012, the Facility was upgraded to two ramp lanes, two finger jetties, a larger turning area and associated scour protection. A new ablution block was constructed in 2013. The original fish cleaning station was removed as a part of the Facility upgrade. The recent history of Facility can be seen in the following figure.



**Figure 2.1 Aerial Photographs of Facility's Recent History**

The design of the Facility upgrade in 2012 was completed by URS and drawings are attached as Appendix B.

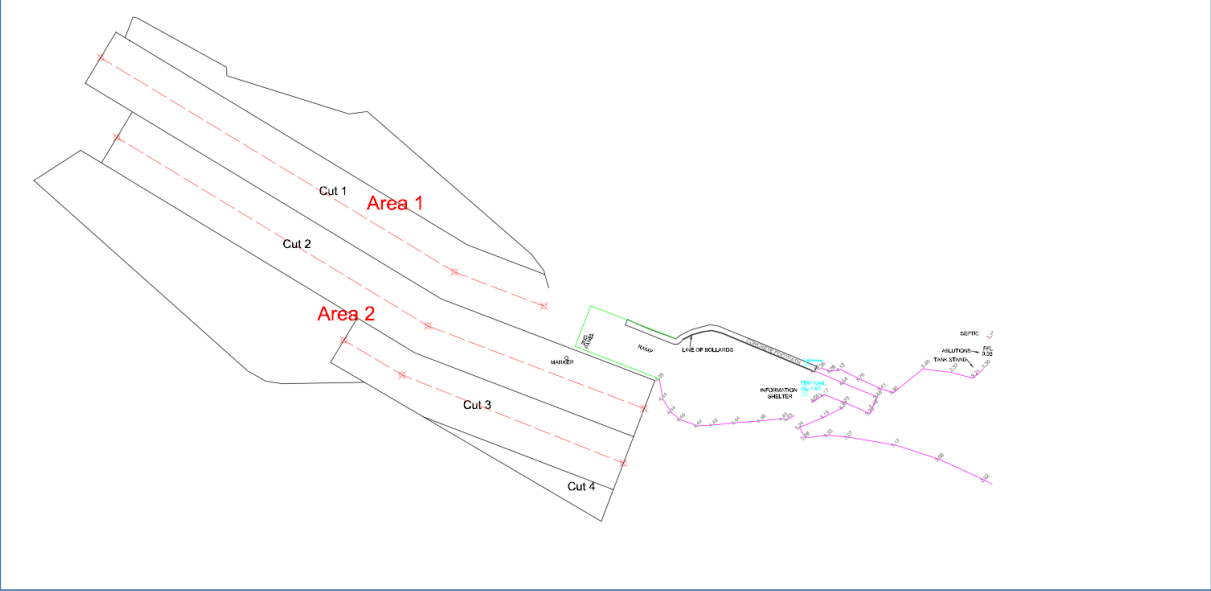
### 2.2 Historical Facility Management

Historically, the maintenance of the Facility has included ongoing excavation or dredging of sediment that accumulates to the south and offshore of the Facility as well as minor repairs and general maintenance to the structures. Typically, the excavated material has been removed from the beach or ocean and placed onshore behind the dunes. General maintenance completed by the Shire includes waste collection, cleaning of the ablution block, sewage disposal and maintaining water supply.

The annual maintenance costs of the Facility estimated by the Shire are in the order of \$170,000 per year. These estimates have been used in the maintenance cost projections outlined in Section 5 of the report.

The Shire also completed dredging of the seabed seaward of the Facility and maintenance of the revetment in 2015. These works were managed by URS Australia Pty Ltd (URS) and the works were undertaken by CGC Dredging and Exmouth Quarries. The total cost of these works was approximately \$620,000 excluding GST. Drawings detailing the extent of works are attached as Appendix C.

Budget constraints experienced during the works resulted in the dredged area being revised to the area shown in the following figure. Approximately 3,000 to 5,000 m<sup>3</sup> of dredge spoil was removed and placed on the beach to the north of the Facility. A large proportion of the material consistent of rubble (URS 2016).



**Figure 2.2 Revised Dredged Areas (URS 2015)**

## 3. Existing Site Conditions

### 3.1 Site Setting

#### 3.1.1 Regional Geology

The Facility is located on the western coastline of the North West Cape. The Department of Mines and Petroleum (DMP) have completed geological surveys of Western Australia (DMP 1978). Figure 3.1 shows an extract from the Onslow (SF5) tile of the survey covering the study area.

As seen in Figure 3.1, the geology surrounding the Facility can be summarised as follows:

- Offshore consists of the living coralgall Ningaloo Reef.
- Onshore consists of beaches and coastal dunes which are classified as unconsolidated and poorly consolidated quartzose calcarenite.
- The area landward of the Facility before the Cape Range ridges, is classified as calcarenites and calcirudites and shallow marine and minor eolian coralgall reef deposits.
- The Cape Range ridges are classified as redish to yellowish shallow marine partly clayey foraminiferal calcarenitic packstone, known as Tulki Limstone.

Given the locality of Tantabiddi Creek in relation to the Facility and its ability to carry deposits downstream during heavy rainfall events, it is likely that a range of deposits from the above geological categories are present in the nearshore area surrounding the Facility and the associated entrance channel.



### 3.1.2 Metocean Conditions

#### Wind Climate

The wind regime influences coastal processes through the generation of waves as well as feeding dune systems with wind-blown beach sand.

The wind regime at the Facility generally consists of strong and persistent southerlies during the summer months and more variable winds in winter (DoF, 2015).

#### Waves

No wave data has been made available for this investigation. However, based on a review of the nearshore bathymetry, aerial photographs, and from the site inspection, the following provides a summary of the wave climate at the site.

- Seas are generated locally by the wind. These can be generated within the lagoons shoreward of the offshore reefs. These seas are typically from the south to southwest direction.
- The prevailing swell wave direction at the site is largely dominated by the diffraction and refraction of waves through the offshore and nearshore reef systems. Under typical conditions most of the swell energy at the site comes from the northwest direction as waves travel through the Tantabiddi passage. This is shown in the figure below.
- The nearshore reefs provide a large amount of sheltering at the site to ocean waves.

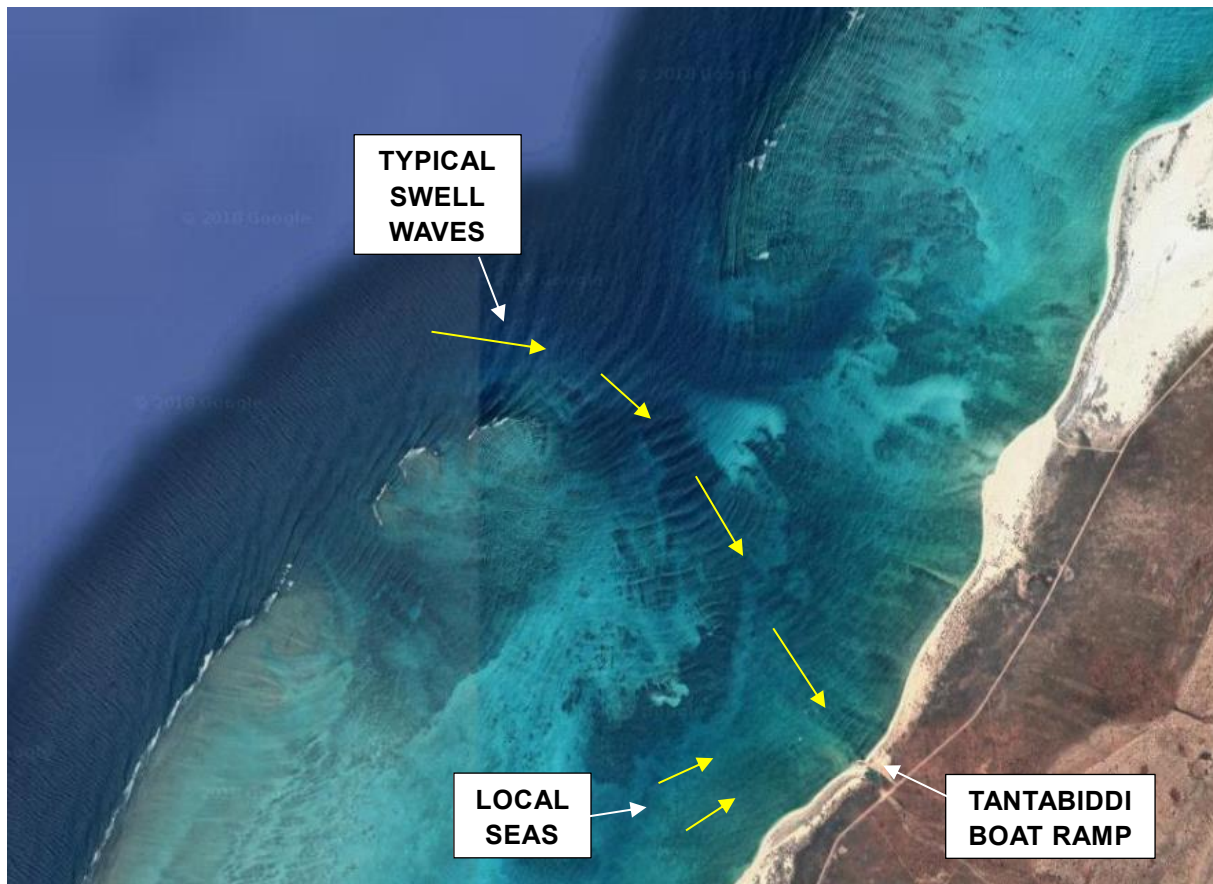
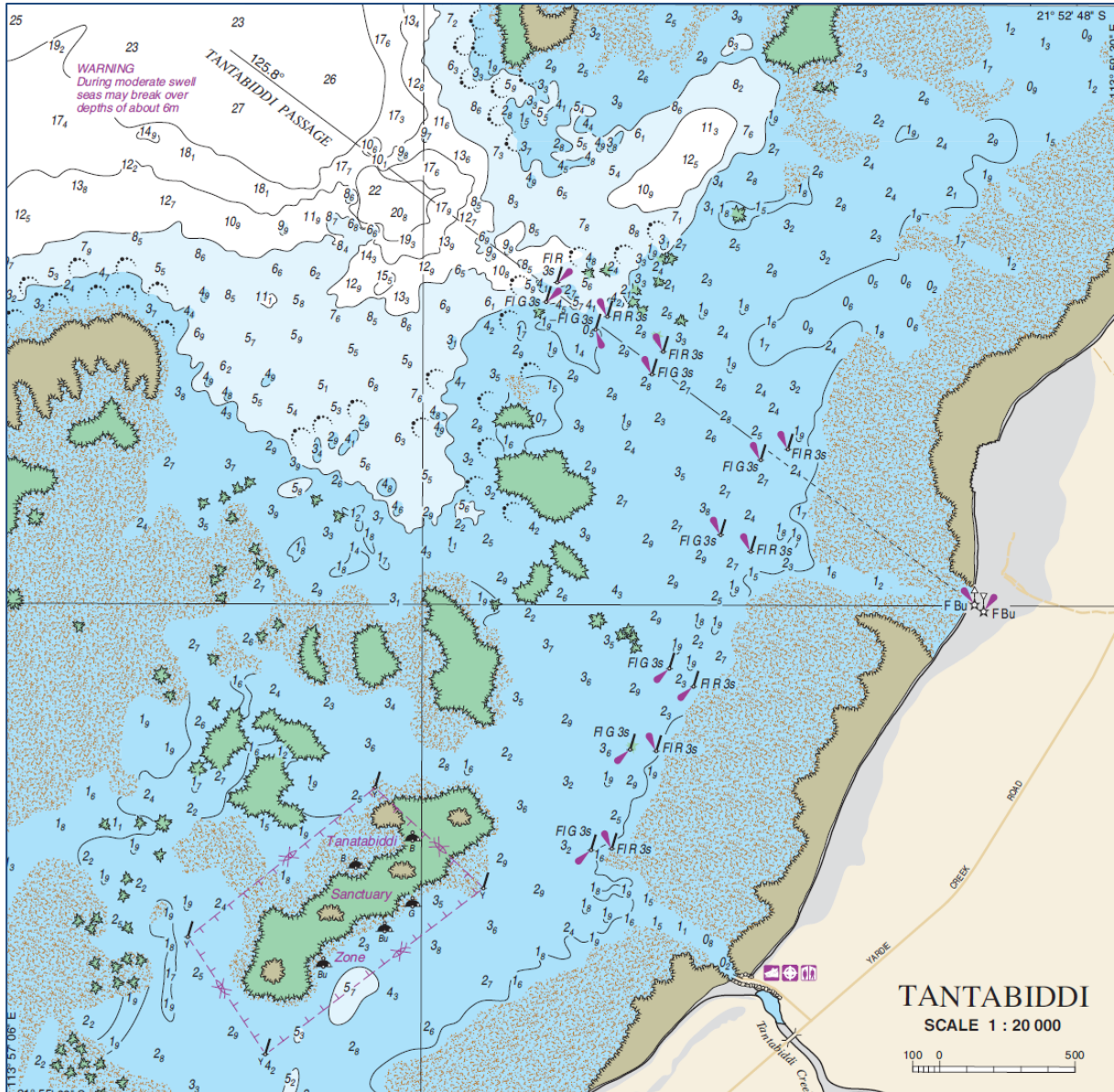


Figure 3.2 Swell Waves Reaching the Site

- It is noted that during cyclonic events and the associated high-water levels, waves may reach the site from a variety of directions.

An extract from the nautical chart is shown in the following figure. This clearly shows the nearshore reefs surrounding the boat ramp and the protection they offer from waves.



**Figure 3.3 Nearshore Bathymetry (extract from DoT Chart WA900)**

Given the exposure of the Facility, it is likely that the wave heights at the ramp would be greater than those required by the Australian Standards for good launching conditions (AS3962 – Guidelines for design of marinas).

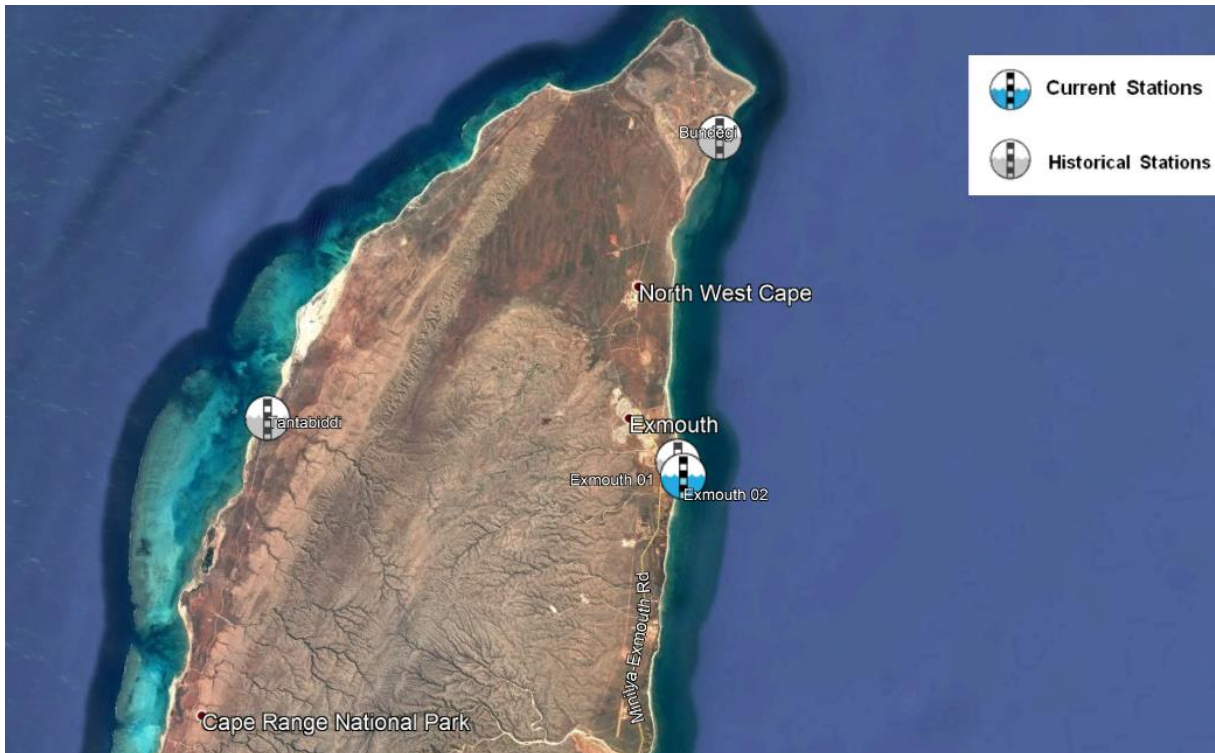
It is recommended that, as an additional investigation for the development of potential upgrades of the Facility, a more detailed wave assessment is completed. This is likely to require wave measurements at nearshore and offshore locations and detailed wave modelling.

### Currents

No current data has been made available for this investigation. It is recommended that, as an additional investigation for the development of potential future upgrades to the Facility, current measurements are completed as a part of the wave measurement program. The use of an Acoustic Wave and Current (AWAC) device would be considered appropriate.

### Water Levels

DoT measures water levels at a number of locations around Western Australia. Historically, there are a number of location within the vicinity of the Facility where water levels have been recorded. These locations are shown in the following figure.



**Figure 3.4 Locations of Water Level Data**

A submergence curve has been generated by DoT for Tantabiddi and is attached as Appendix D. Table 3.1 summarises the tidal planes from the Tantabiddi tidal gauge.

**Table 3.1 Tantabiddi Tidal Planes (DoT 2006)**

Tide	Elevation (m)	
	Chart Datum	AHD
Highest Astronomical Tide (HAT)	2.04	1.03
Mean High Water Spring (MHWS)	1.60	0.59
Mean High Water Neap (MHWN)	1.31	0.30
Mean Sea Level (MSL)	1.07	0.06
Australian Height Datum (AHD)	1.01	0.00
Mean Low Water Neap (MLWN)	0.87	-0.14
Mean Low Water Spring (MLWS)	0.54	-0.47
Lowest Astronomical Tide (LAT)	0.10	-0.91

Notes: 1. Taken from Tantabiddi submergence curve (DoT 1615-21-01).

Out of the tidal gauge locations shown in Figure 3.4, only the Exmouth 02 tidal gauge is currently active and is the longest data set available in the region. The tide experienced at the Exmouth 02 site and the Tantabiddi site are comparable under the majority of conditions. The Exmouth 02 water level data set was analysed by MRA as a part of an extreme water level assessment of tidal gauges around Western Australia (MRA, 2014). The results of MRA (2014), together with the DoT submergence curves, have been used to guide the design of the concept level Facility upgrade options discussed in Section 6 of this report.

### 3.1.3 Indicative Sediment Transport Pathways

Based on a brief review of wind regime, available historical aerials and knowledge of sediment management practices, the following figure presents the indicative sediment transport pathways that have used to guide the design of the concept level Facility upgrade options discussed in Section 5 of this report.



**Figure 3.5 Indicative Sediment Transport Pathways**

As shown in Figure 3.5, sediment can be transported up or down the coast due to the prevailing wave, wind and current conditions. As the dominant wind and waves at the site are from the southwest the net longshore sediment transport is likely to be from the southwest to the northeast.

This is supported by the historical aerial photographs that show since the Facility was constructed it has interrupted the natural longshore sediment transport resulting in accretion of the shoreline on the southern side of the Facility and erosion of the northern side. It is estimated that the net northerly transport could be in the order of 5,000 m<sup>3</sup>/yr. However, this estimate is indicative only and would need to be assessed in greater detail.

Flows from the Tantabiddi Creek also supply sediment to the nearshore area during heavy rainfall events, which can create issues with navigation and launching/retrieving vessels.

It is recommended that, as the potential concept upgrades of the Facility progress into the later stages of design, a more detailed sediment transport assessment is completed to confirm the observations above and estimate quantities of sediment movements. This process is likely to require detailed assessment of historical aerial images, analysis of existing survey and completion and analysis of additional surveys of the nearshore area and dredge spoil stockpiles. Detailed sediment transport modelling may also be required.

### 3.2 Site Inspection

The site was inspected by Coastal Engineer, Tom Harding, of MRA at 10:30am on Monday, 23 April 2018. Photographs of the Facility during the inspection are presented in the following figure.







**Figure 3.6 Photographs of the Facility**

An above water visual inspection of the structures was undertaken. In general, the Facility appeared to be in good condition. Defects that were noted during the inspection are listed in the following table.

The revetment protecting the facility appeared to have a large portion of armour rock that was less than the 1.0t to 2.5t limestone specified in URS (2015). When exposed to severe wave conditions during cyclonic events, this small rock would increase the likelihood of damage to the revetment and potentially the Facility. The small rock may be fully displaced and act as projectiles that could be thrown by wave energy onto the boat ramp lanes and turning area. This would pose a safety hazard to the users of the facility and should be seen as a risk to the Shire. It is recommended that the Shire manage this risk, and the other risks associated with cyclonic events, by closing the Facility during cyclonic events.



**Table 3.2b Facility Defects (Cont.)**

Item	Defect	Photograph
Fibre Reinforced Polymer (FRP) grating deck	Vessel damage to overhanging sections of grating	
Revetment	Large portion of undersized rock present in armour layer	
Limestone block wall	Displacement of southern limestone blocks and loss of mortar	
Ablution block	Missing taps	

The carpark consisted of limestone roadbase with no line markings. This results in the users of the Facility parking in an uncontrolled and inefficient manner as shown in the following figure.



**Figure 3.7 Photographs of the Facility Carpark**

Typically, it appears that the carpark is used in the following manner:

- Buses used by the commercial operators to transport passengers to the Facility are parked on the southern edge of the carpark on the boat ramp approach (as seen in the top left-hand side of Figure 3.7).
- Cars with trailers (commercial and recreational) are parked in the centre of the carpark starting from the entry to the boat ramp turning area and are parked diagonal to the boat ramp approach.
- Cars without trailers are parked on the north western edge of the carpark.

The northern edge of the carpark (as seen on the top right-hand side of Figure 3.6) appeared to be a disposal ground for the excavated sediment from the Shire's annual management operations. It is understood that the dredge spoil from the large-scale dredging works, designed and managed by URS for the Shire in 2015, was deposited on the beach to the north of the ramp.

A vehicle count was completed at 11:30am during the inspection. The results of the vehicle count are outline in the following table.

**Table 3.3 Vehicle Count During Inspection**

Operators	Number of Vehicles			
	Cars	Cars & Trailers	Buses	Buses & Trailers
3 Island Whale Shark Dive	-	-	2	-
Exmouth Dive & Whale Sharks Ningaloo	-	-	1	-
Exmouth Diving Centre	-	-	2 (mini vans)	-
Kings Ningaloo Reef Tours	-	1	1	-
Ningaloo Discovery	-	1	2	-
Ningaloo Whale Shark N Dive	-	1	1	-
Ocean Adventures	-	-	1	-
Ningaloo Ecology Cruisers	1	-	-	-
Peak Sport Fishing	-	1	-	-
Ningaloo Blue Charters	-	1	-	-
On Strike Charters Exmouth	-	1	-	-
<i>Unmarked Vehicles</i>	17	24	2	-
<b>Total</b>	<b>18</b>	<b>30</b>	<b>12</b>	<b>0</b>

Based on the number of vehicles (cars, cars & trailers and buses) during the inspection, the car-park was occupied by approximately 30% commercial vehicles and 70% recreational vehicles. This is on the assumption that all unmarked vehicles were recreational vehicles (with exception of the 2 unmarked buses). This estimate is only a spot check is only representative of the car-park usage, not the boat ramp, finger jetties or Facility as a whole.

One of the Shire's maintenance staff was present at the Facility during the inspection. A photograph of the work vehicle and waste management trailer can be seen in the following figure.



**Figure 3.8 Shire's Maintenance Vehicle & Waste Management Trailer**

Discussions were held with the Shire employee regarding the maintenance procedures and current conditions of the site. A summary of the discussion is outlined below:

- Rubbish bins are collected daily. Currently limited to four rubbish bins per day. These are commonly overflowing with rubbish during the peak season. This results in rubbish blowing around the Facility.
- The water tank that supplies the ablution block is filled up daily. In recent years, the Shire has blocked all taps in the ablution block as a result of water storage limitations. This results in visitors commonly requesting use of water from the maintenance vehicle to wash their hands after using the ablution block.
- There used to be a fish cleaning station prior to the Facility upgrade in 2012. This was removed partly as a result of water supply/storage limitations, additional waste burden and mistreatment by Facility users.

## 4. Facility Usage Assessment

The current and future usage of the facility has been investigated using the follow four sets of information:

- Online Boat Users Surveys.
- Traffic Counter Data.
- Whale Shark Tour Participants Data.
- Boat Registration Data & Population Projections.

It is understood that the following government agencies and public service groups currently use the Facility for research and services in the area:

- DBCA.
- Department of Fisheries.
- Exmouth Volunteer Marine Rescue.

No further investigation of the usage of the existing Facility by the above-mentioned government user groups has been conducted or specifically categorised. However, for the purposed of this investigation and the associated future infrastructure requirements, the frequency of usage by the above-mentioned user groups has been captured under the data collected and the recreational user group assessment.

This investigation has used the most recently available data from the following sources:

- Online Boat User Survey (MRA, 2018).
- Residential Population Statistics (Australia Bureau of Statistics (ABS), 2016).
- Population Growth Projections (ABS, 2012).
- Population Growth Projections (Shire, 2012).
- Vessel Registration Statistics (DoT, 2018).
- Traffic Counter Data (DBCA and MRA, 2018)

The historical statistics and local information have been used to establish trends which have then been used in conjunction with population growth scenarios to determine the future demand for the Facility.

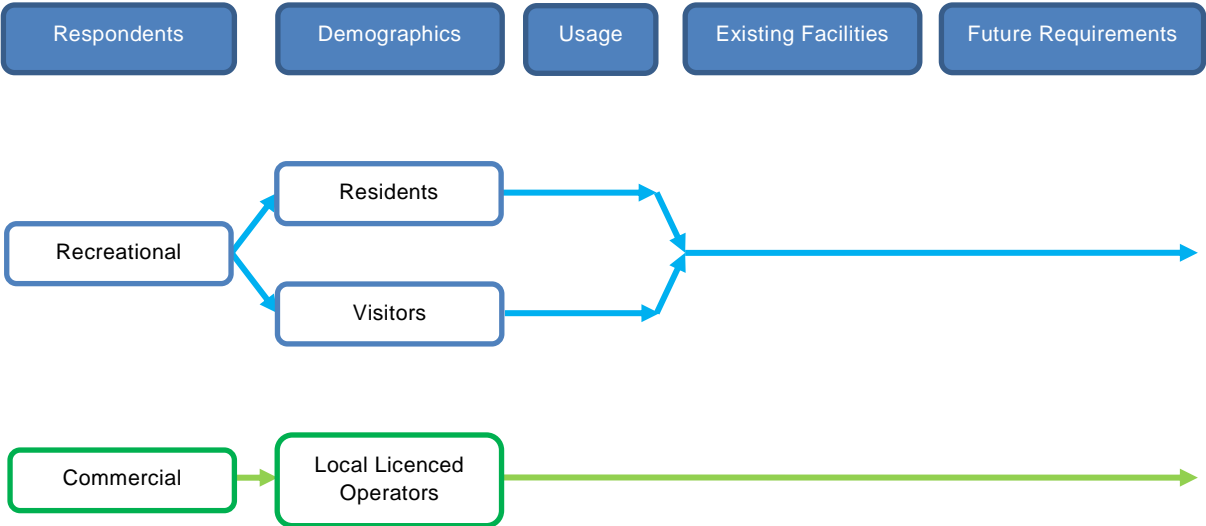
The assessment of these data sets is presented in the following sections.

### 4.1 Online Boat User Surveys

Given the facility is currently utilised by both commercial and recreational users, two separate online services were developed to capture usage of the Facility by these user categories. The survey was designed to capture the following data for assessment:

- Boat User Demographics.
- Facility Usage.
- Existing Facilities Issues.
- Future Requirements.

The design flow process of the online surveys can be seen in the following figure.



**Figure 4.1 Online Survey Design Flow Process**

The outcomes of the two surveys are present in the following sections. Responses to the Recreational User Survey are provided in Section 4.1.1 and responses to the Commercial User Survey are provided in Section 4.1.2.

#### 4.1.1 Recreational Users

Over 1,000 responses were received for the recreational user survey, demonstrating a large interest in the facility from local, national and international users. Responses from the recreational users are provided below.

## Demographics

### Respondents

Each respondent was questioned on if they had used the Facility in the past. Those that had not used the Facility in the past were unable to comment on usage of the ramp or the existing facilities.

The number of the respondent's and the location of their permanent residency is diagrammatically presented in the following figures.

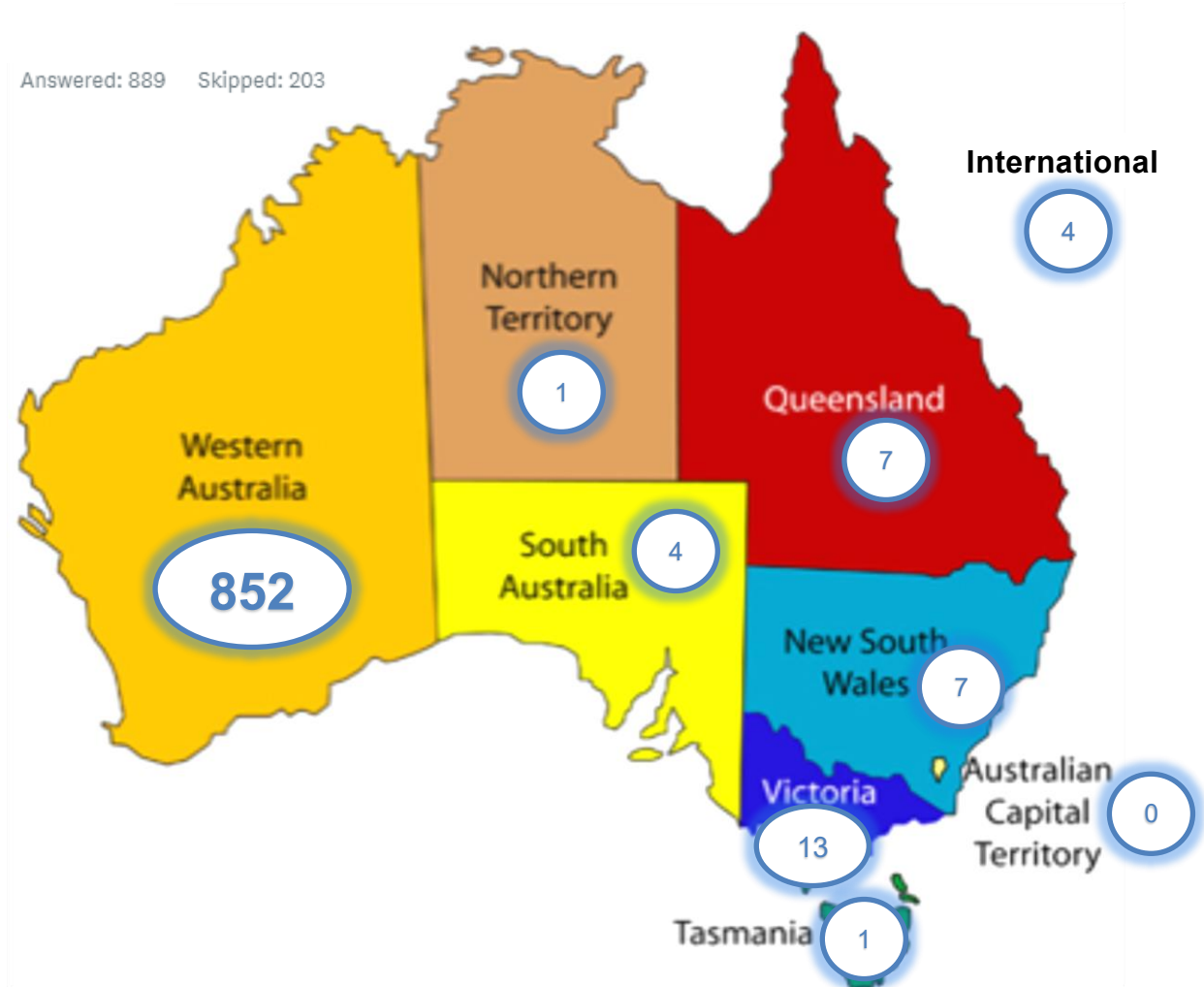


Figure 4.2 Number of Respondents by Residency Location

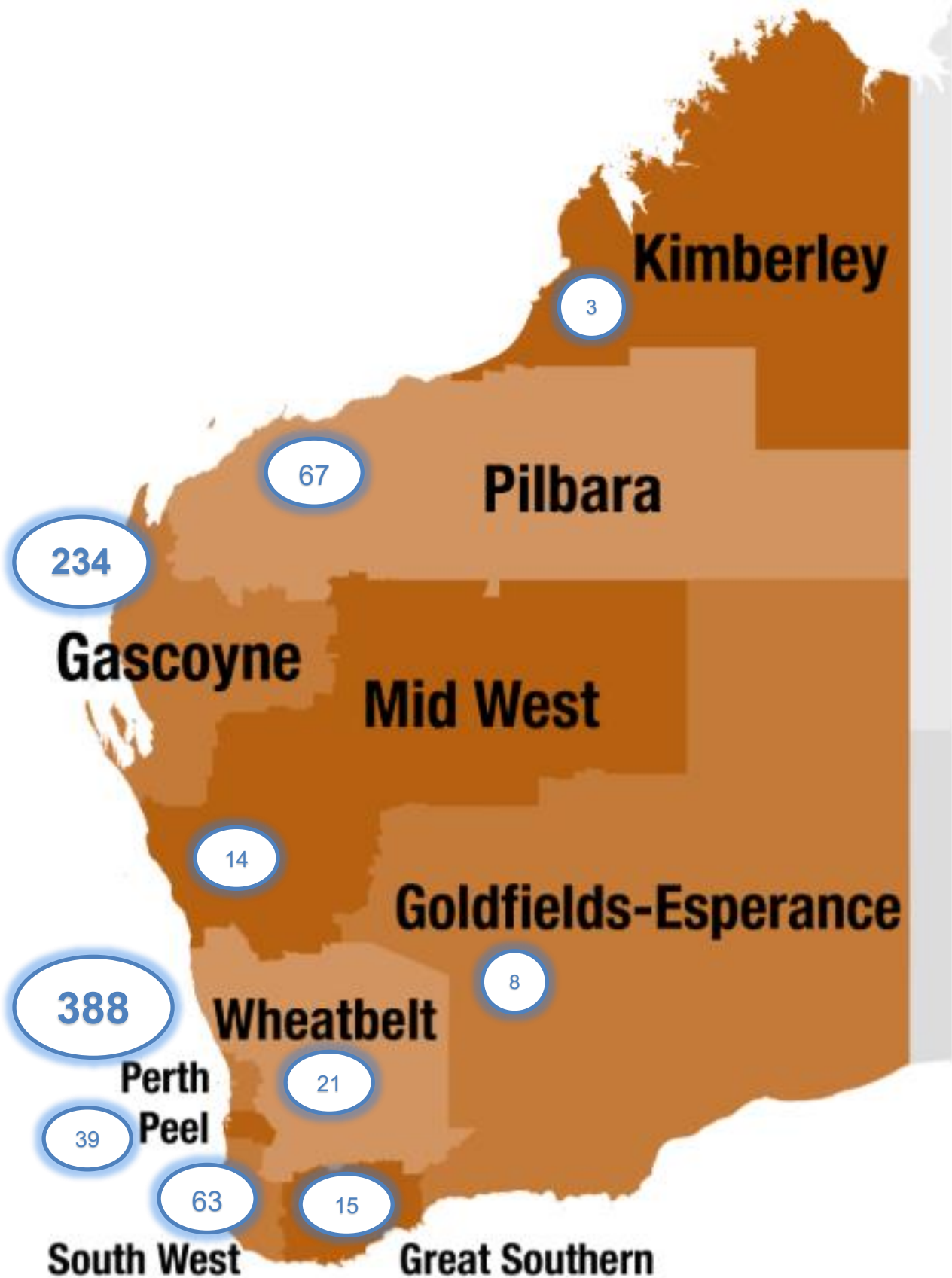
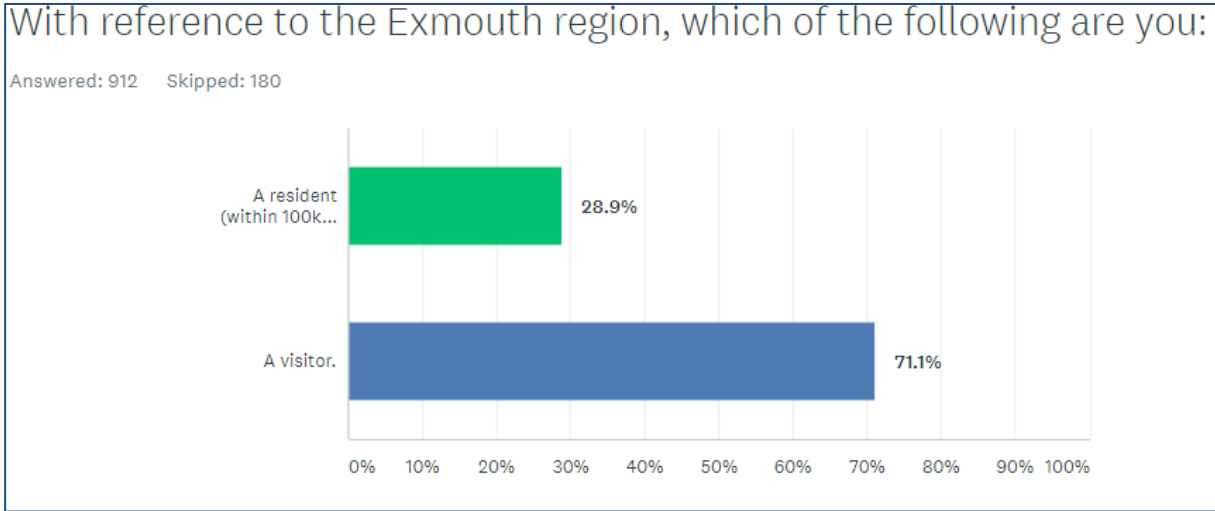


Figure 4.3 Number of Respondents by WA Region

Given the anticipated different usage trends of visitors and residents, a different set of questions regarding usage of the Facility was provided the visitors and residents of the Exmouth Region. The following question response results shows the distribution of respondents who classified themselves as a resident or a visitor.



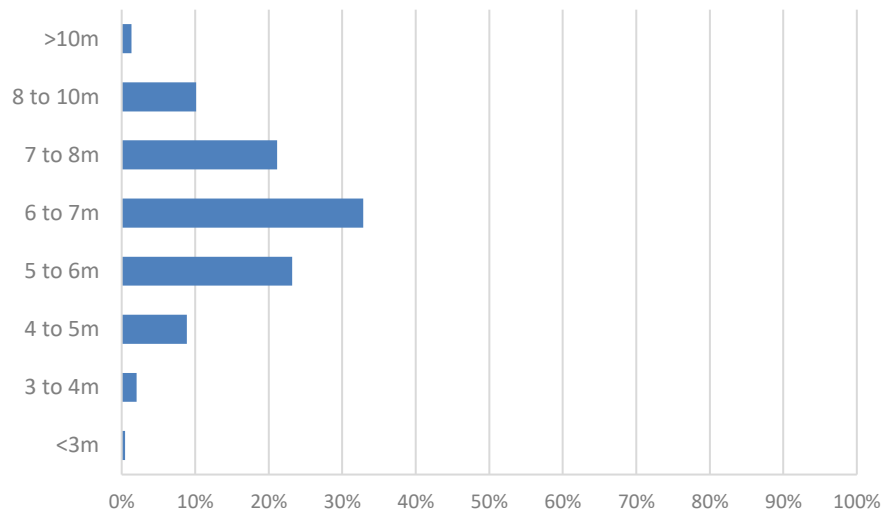
It is noted that respondents from the Lower West Region (ie Perth and surrounds) made up approximately 65% of the 'visitors'.

## Facility Usage

### Vessels Sizes

Please enter the length of the vessel you used at the Tantabiddi Boat Launching Facility:

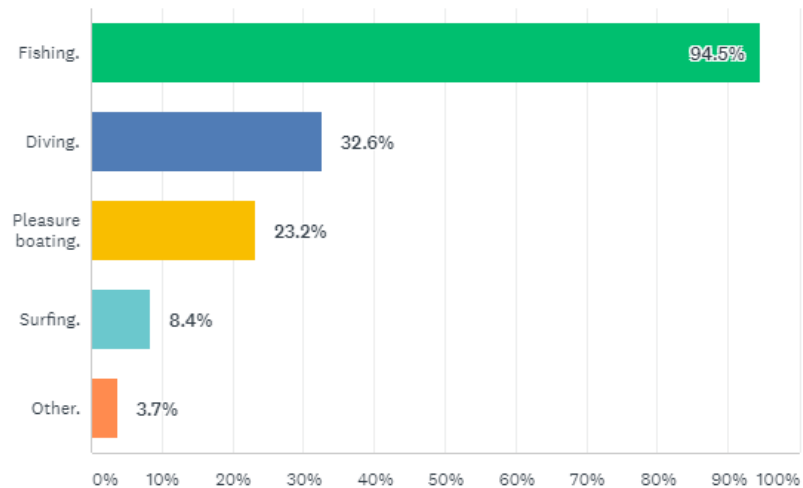
Answered: 889 Skipped: 203



### Main Activities – Residents & Visitors

When in using the Tantabiddi Boat Launching Facility, what are the main activities that you use your boat for?

Answered: 912 Skipped: 180



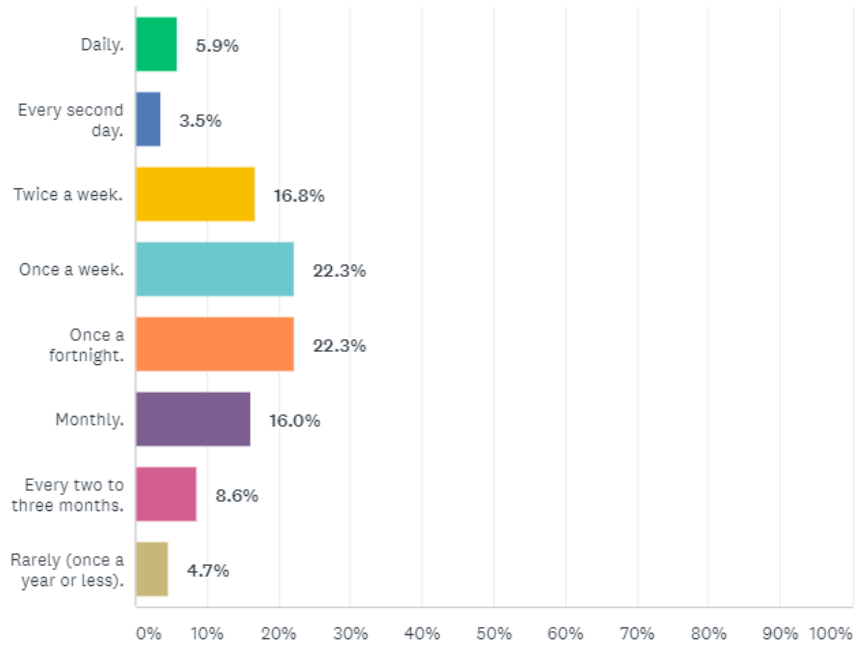
Other activities specified by respondents included snorkelling, spearfishing, kayaking, wildlife viewing, water skiing and work (research and tourism).

**Residents (within 100 km of Tantabiddi)**

The following two questions only relate to respondents who classify themselves as residents of the Exmouth Region.

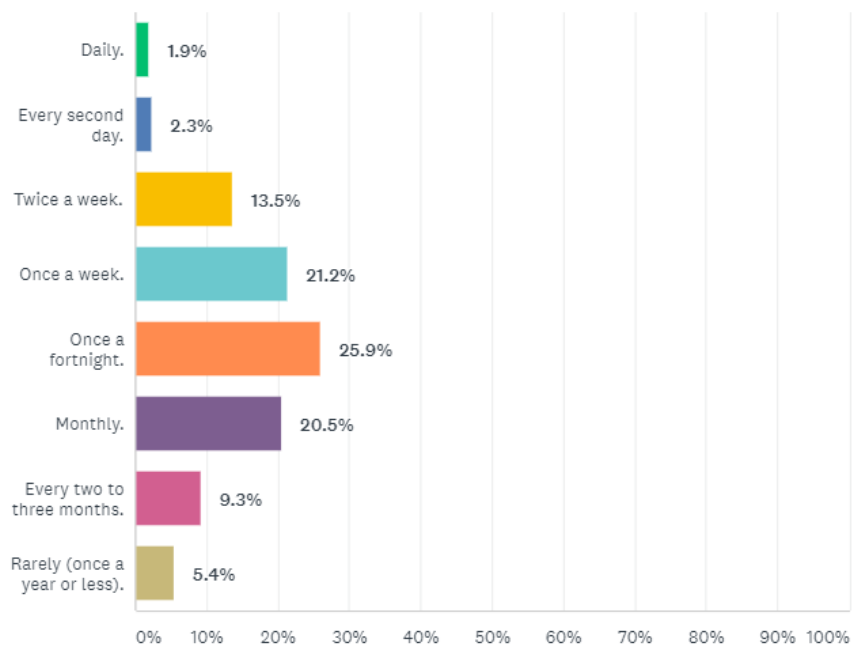
How often do you typically launch your vessel from the Tantabiddi Boat Launching Facility between April and September?

Answered: 256 Skipped: 836



How often do you typically launch your vessel from the Tantabiddi Boat Launching Facility between October and March?

Answered: 259 Skipped: 833

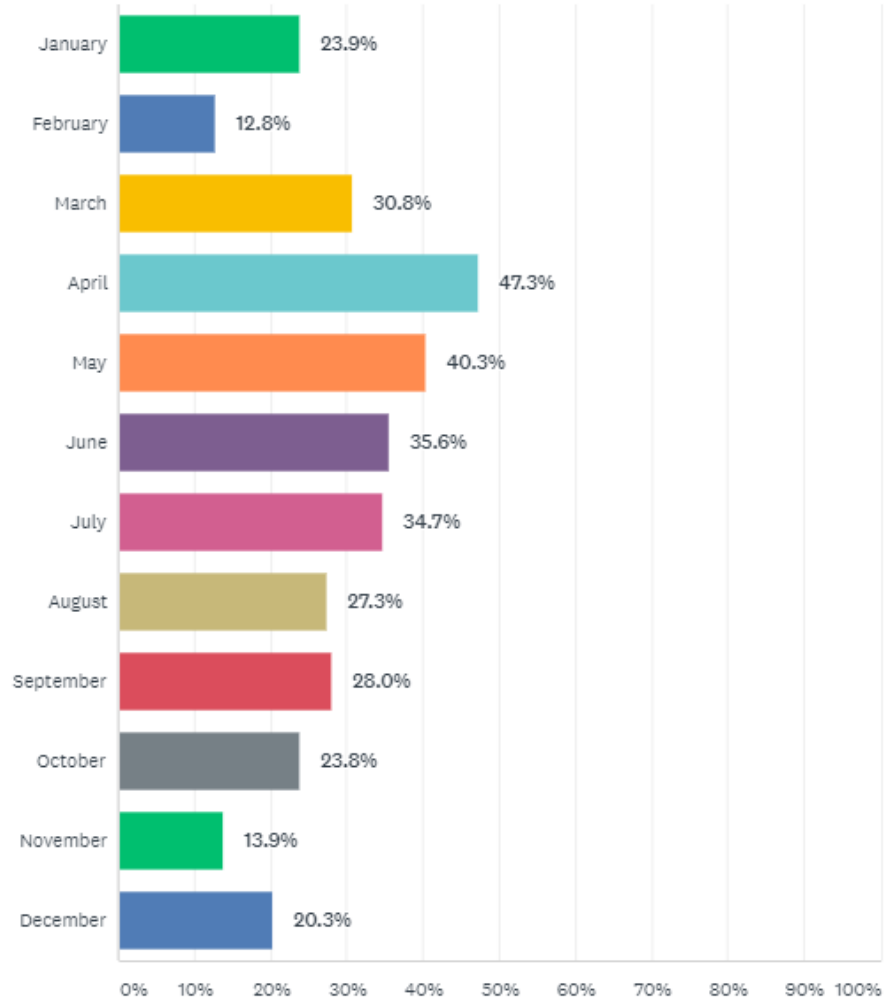


### Visitors

The following questions relate to visitors to the Exmouth Region.

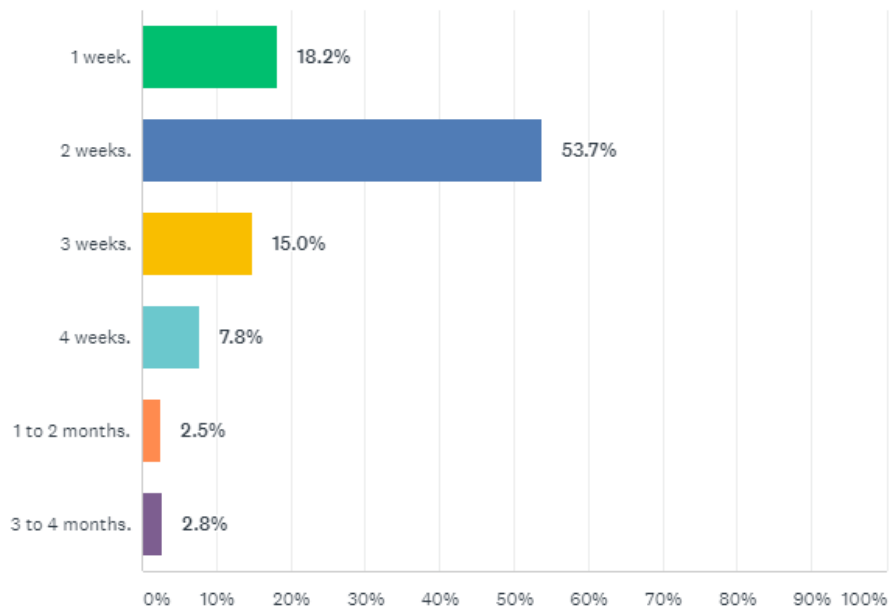
What month(s) of the year do you typically use the Tantabiddi Boat Launching Facility?

Answered: 640 Skipped: 452



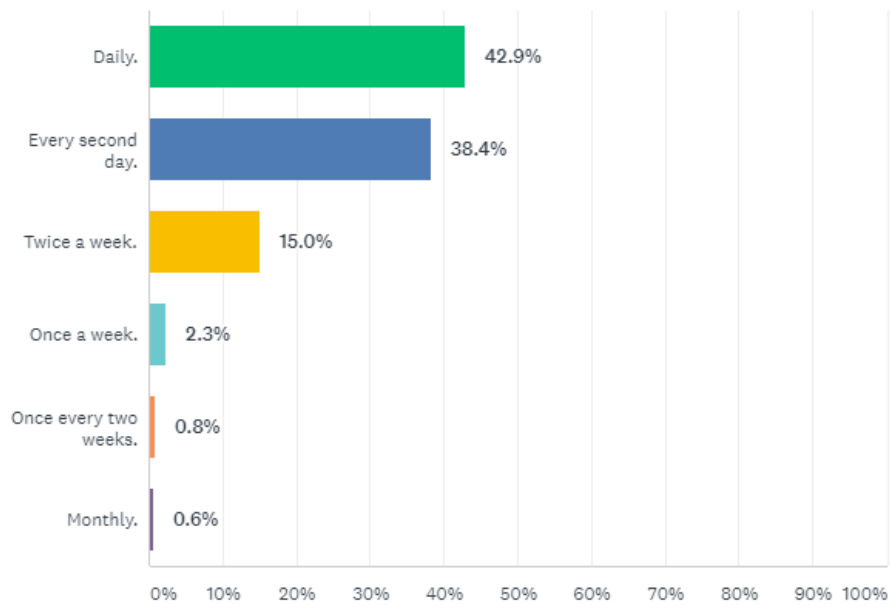
## Typically what is the length of your stay in the region?

Answered: 642 Skipped: 450



## During a typical stay in the region, how often would you launch at the Tantabiddi Boat Launching Facility?

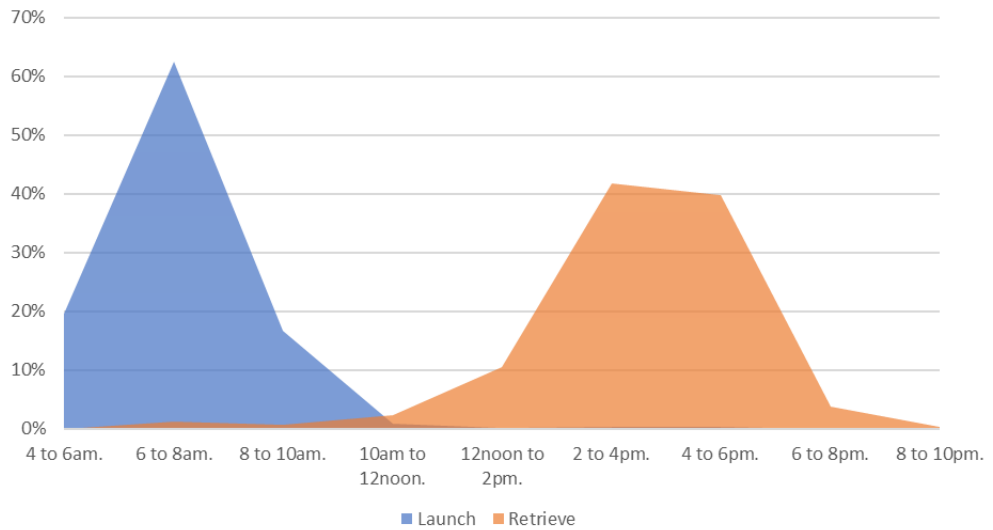
Answered: 641 Skipped: 451



### Launch/Retrieval Times – Residents & Visitors

What time of day do you typically launch/retrieve your vessel from the Tantabiddi Boat Launching Facility?

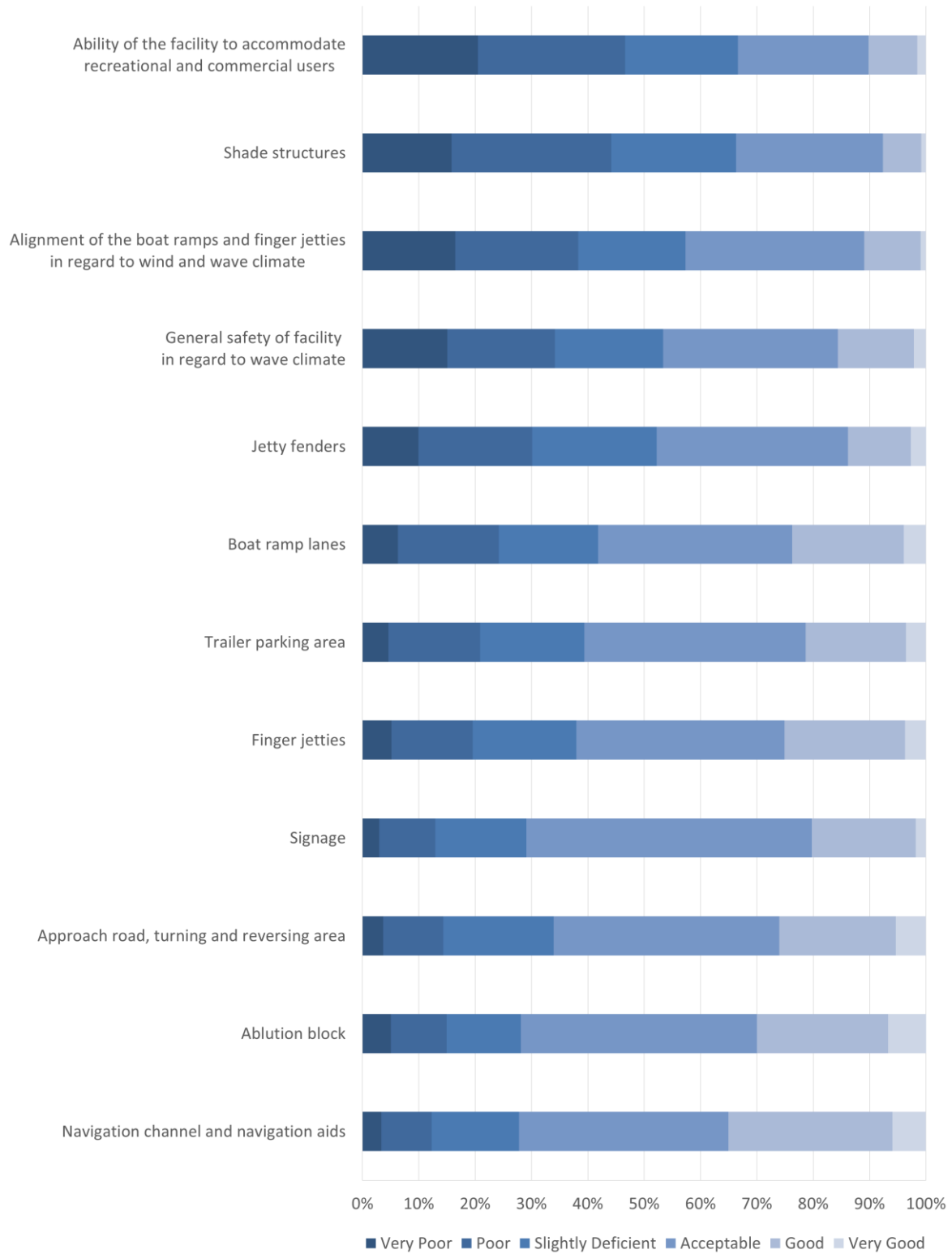
Answered: 895 Skipped: 197



## Existing Facilities

Please rate the adequacy of each of the following items at the Tantabiddi Boat Launching Facility:

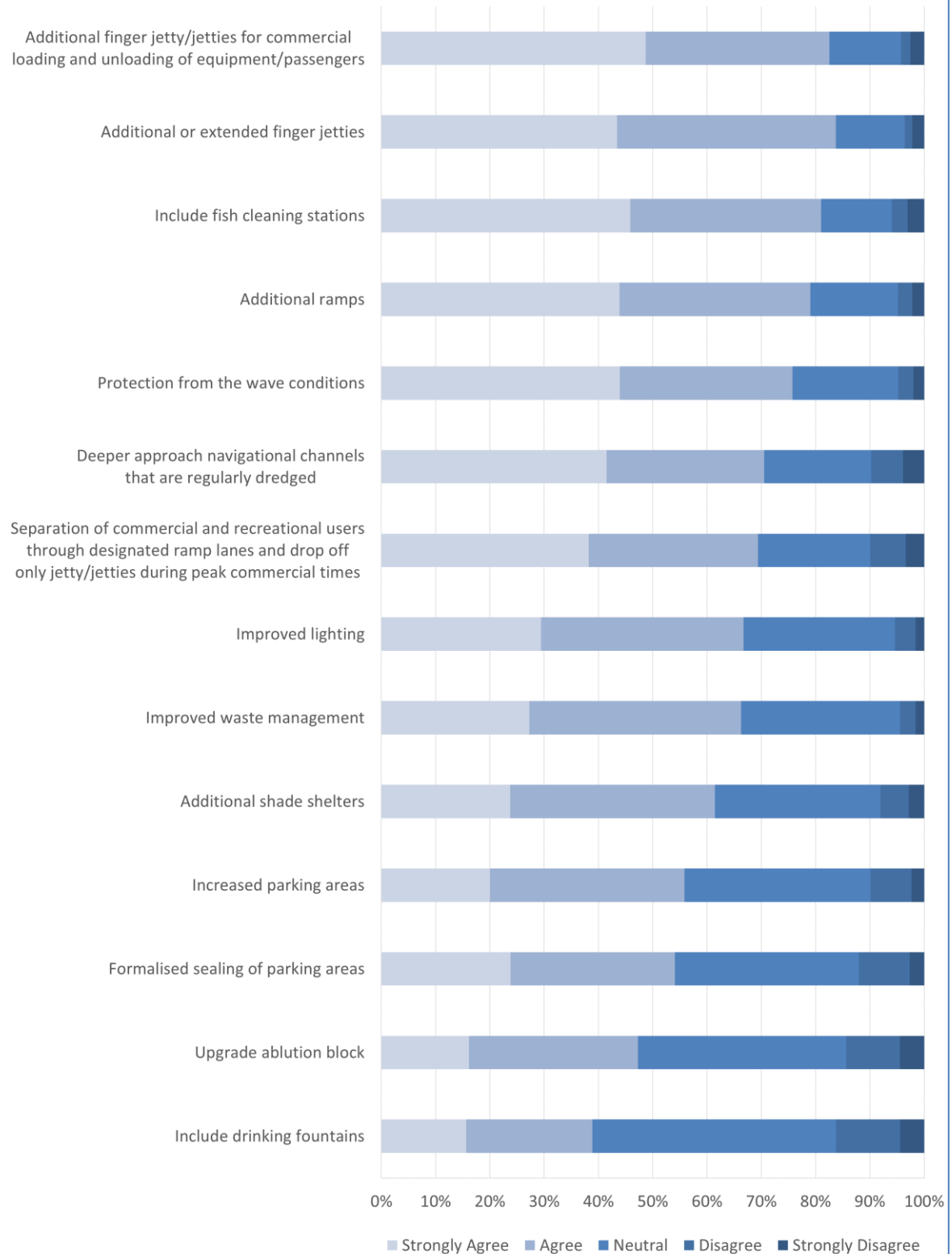
Answered: 847 Skipped: 245



## Future Requirements

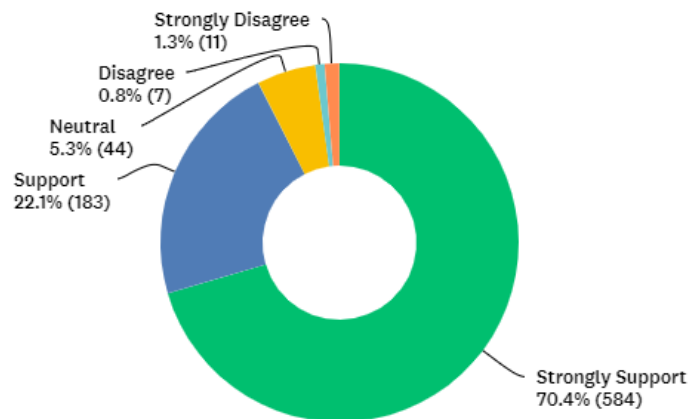
Please confirm your level of support for future upgrades to each of the following items at the Tantabiddi Boat Launching Facility:

Answered: 829 Skipped: 263



## Do you support an upgrade of the Tantabiddi Boat Launching Facility to improve it's overall functionality?

Answered: 829 Skipped: 263



As seen in the results above, there is strong support for an upgrade of the Facility by recreational users with approximately 92% of respondents supporting or strongly supporting an upgrade. The items identified as priority future requirements to improve the user experience, safety and alleviate congestion of the Facility include the following:

- Additional finger jetty/jetties for commercial loading and unloading of equipment/passengers.
- Additional or extended finger jetties.
- Include fish cleaning stations.
- Additional ramps.
- Protection from the wave conditions.
- Deeper approach navigational channels that are regularly dredged.
- Separation of commercial and recreational users through designated ramp lanes and drop off only jetty/jetties during peak commercial times.
- Improved lighting.
- Improved waste management.

Additional concerns raised by respondents that require consideration for future Facility requirements include the following:

- Fish cleaning station and additional bins.
- Channel marker locations do not correspond with GPS mapping and do not have adequate lighting.

- Usage instructive signage.
- Designated rigging/derigged bays.
- Ramp approach line markings.
- Extension of concrete ramp lanes to allow vessels to safely launch/retrieve at low tides.
- Removal of a rock obstruction in front of southern ramp lane which presents a safety hazard during low tidal periods.
- CCTV cameras in carpark to deter vandalism and theft.
- Small craft ramp to beach on north of the Facility.
- Move loading zone away from turning area and include designated pedestrian path for commercial passenger access.
- Widen bitumen at the intersection of the Facility entrance road and Yardie Creek Road.
- Boat launch/retrieval etiquette signage.

#### 4.1.2 Commercial Users

DBCA provided the following list of 25 commercial operators licenced to use the Facility. The Commercial User Survey was emailed to all commercial operators listed below. The survey was designed to understand the usage of the Facility by existing commercial operators, gain feedback on the adequacy of the existing Facility and any future requirements.

- 3 Islands Whale Shark Dive.
- AQWA.
- Blue Lightning Game Fishing Charters.
- Dive Ningaloo.
- Exmouth Diving Centre.
- Exmouth Flyfishing.
- Fish Tales Snorkeling Tours.
- Flyfishing Frontiers.
- Keshi Mer Expeditions.
- Kings Ningaloo Reef Tours.
- Live Ningaloo.
- Ningaloo Blue.
- Ningaloo Discovery.
- Ningaloo Ecology Tours.
- Ningaloo Pearls.
- Ningaloo Sportfishing Charters.
- Ningaloo Whaleshark-N-Dive.
- Ocean Eco Adventures.
- Onstrike Charters.
- Peak Sportfishing.
- Reel Teaser Fishing Adventures.
- Snorkel Ningaloo.
- South West Water Sports.
- True Blue Bonefish Fishing Charters.
- Ultimate Water Sports.

The commercial operators were requested to have one representative from the company complete the survey and complete the survey for each tender vessel that uses the Facility for launching, retrieving and loading/unloading passengers or equipment.

17 responses were received for the commercial user survey from the following 16 companies, representing a large portion of the commercial operators licenced to use the Facility. 3 Islands Whale Shark Dive completed the survey twice, once for each tender vessel in line with the request. Following consultation with commercial operators, this request was generally an oversight as other companies also use multiple tenders. Therefore, the results of the two submissions from 3 Islands Whale Shark Dive were combined to represent an overall usage estimate for the company.

- 3 Islands Whale Shark Dive.
- Exmouth Diving Centre.
- Exmouth Flyfishing.
- Flyfishing Frontiers.
- Kings Ningaloo Reef Tours.
- Ningaloo Blue.
- Ningaloo Ecology Tours.
- Ningaloo Pearls.
- Ningaloo Sportfishing Charters.
- Ningaloo Whaleshark-N-Dive.
- Ocean Eco Adventures.
- Onstrike Charters.
- Peak Sportfishing.
- Reel Teaser Fishing Adventures.
- Snorkel Ningaloo.
- True Blue Bonefish Fishing Charters.

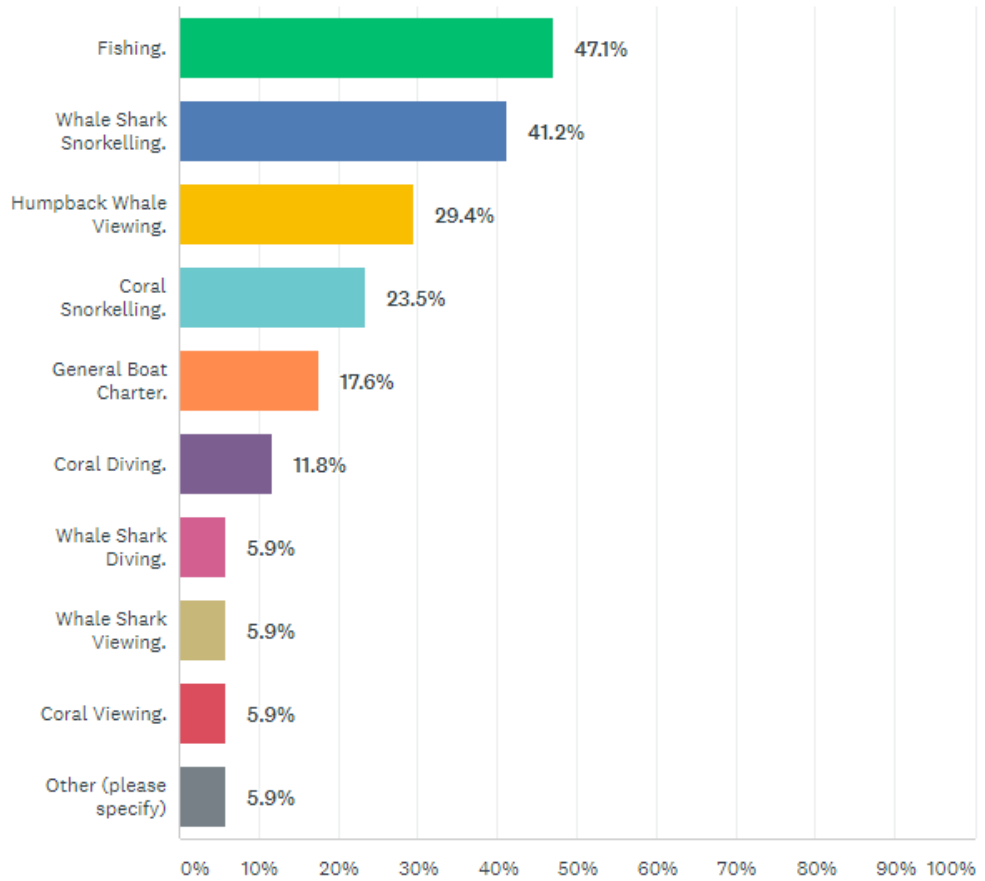
The results from the Commercial User Surveys are provided in the following section.

## Facility Usage

### Main Activities

Please select the tour activity this vessel is associated with:

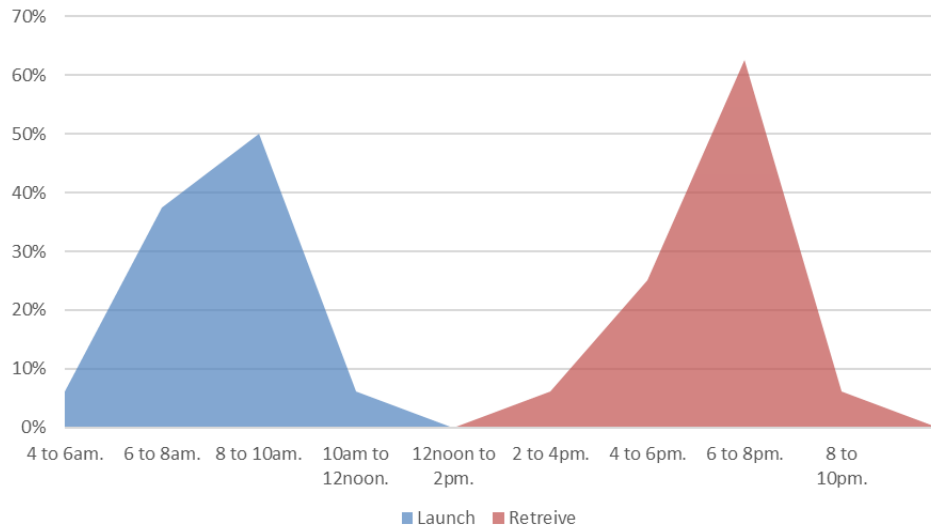
Answered: 17 Skipped: 0



Other responses included catch and release fly fishing which would be classified under fishing.

## What time of day do you typically launch/retrieve your vessel from the Tantabiddi Boat Launching Facility?

Answered: 17 Skipped: 0



The timing of launch and retrieval of commercial tender vessels shown above were typical for the peak seasons of the year. It should be noted that Ningaloo Ecology Tours do not launch or retrieve the vessel described in the survey from the Facility. The vessel described in the survey used the northern face of the northern finger jetty to load and unload passengers. This process can be seen in the photograph taken during the site inspection in following figure.

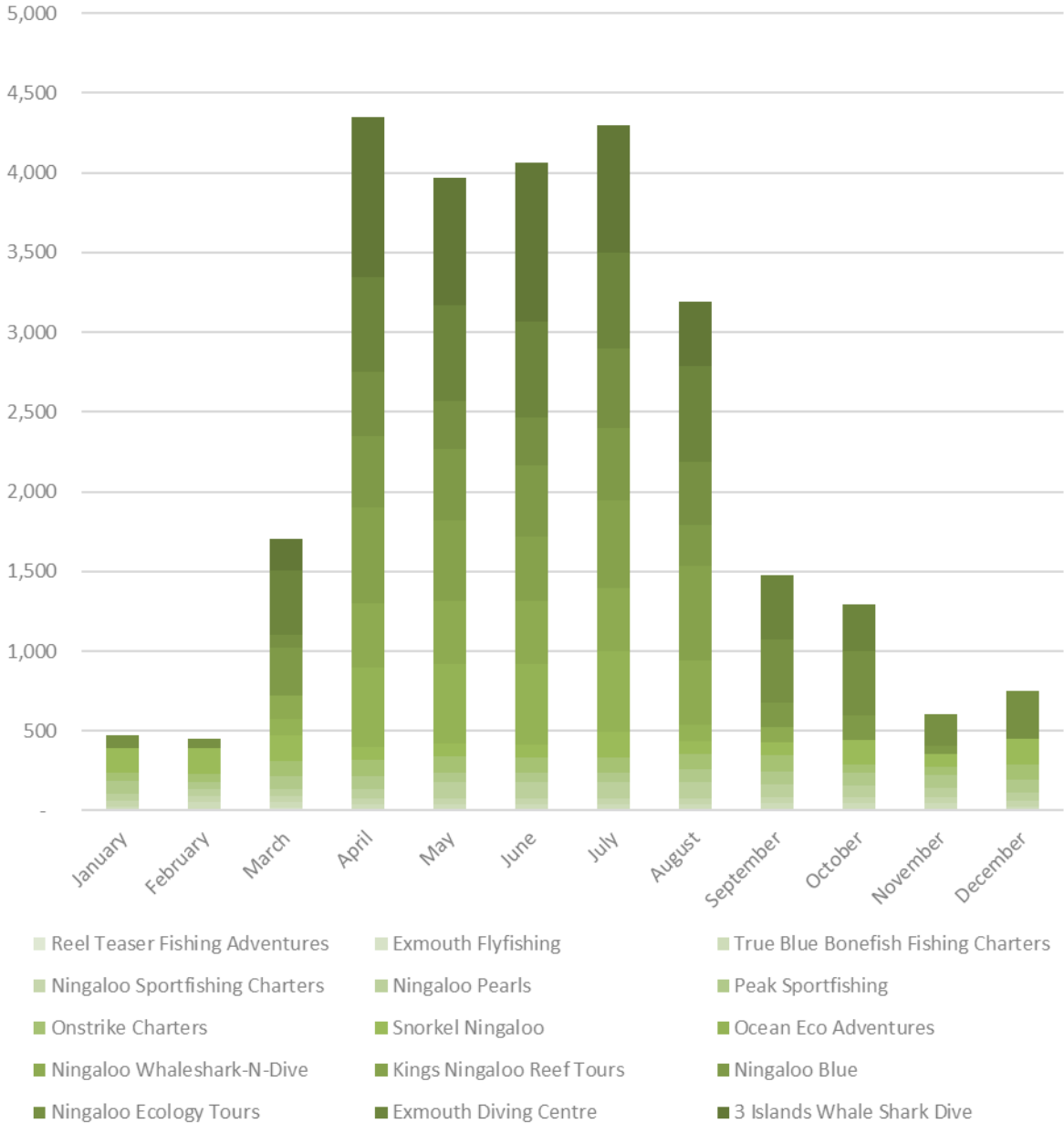


**Figure 4.4 Loading and Unloading of Passengers from Northern Jetty**

The use of the Facility throughout the year varies between the commercial operations, however typically they operate most days during the peak tourism period of the year which has been identified as April to September.

Please enter the number of guests/passengers typically taken on tours each month:

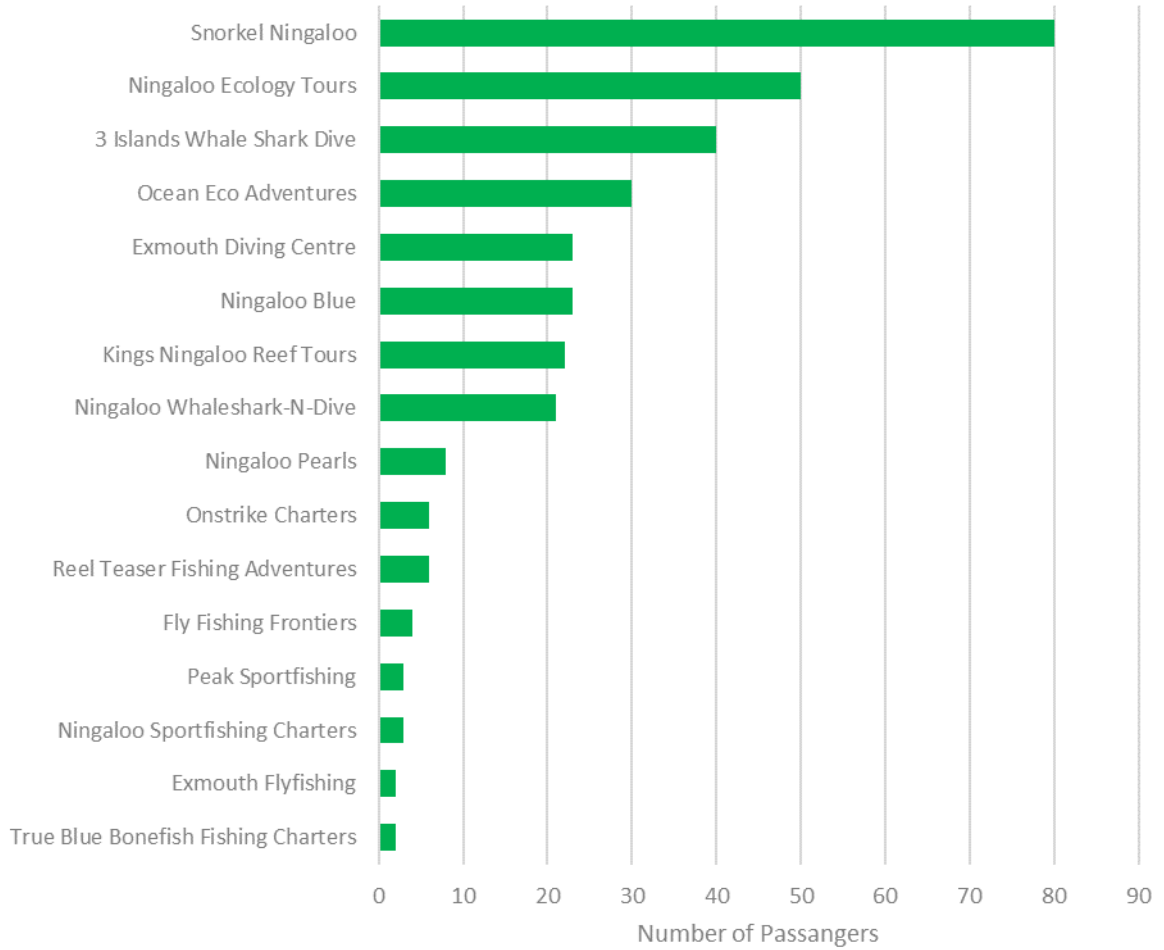
Answered: 16 Skipped: 1



It is noted that Fly Fishing Frontiers skipped this question.

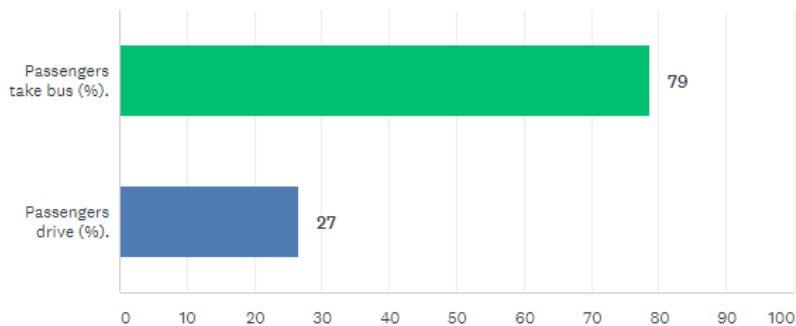
### On a peak day, how many passengers/guests do you have?

Answered: 17 Skipped: 0



### Please enter an approximate percentage of how your passengers access the Tantabiddi Boat Launching Facility:

Answered: 15 Skipped: 2



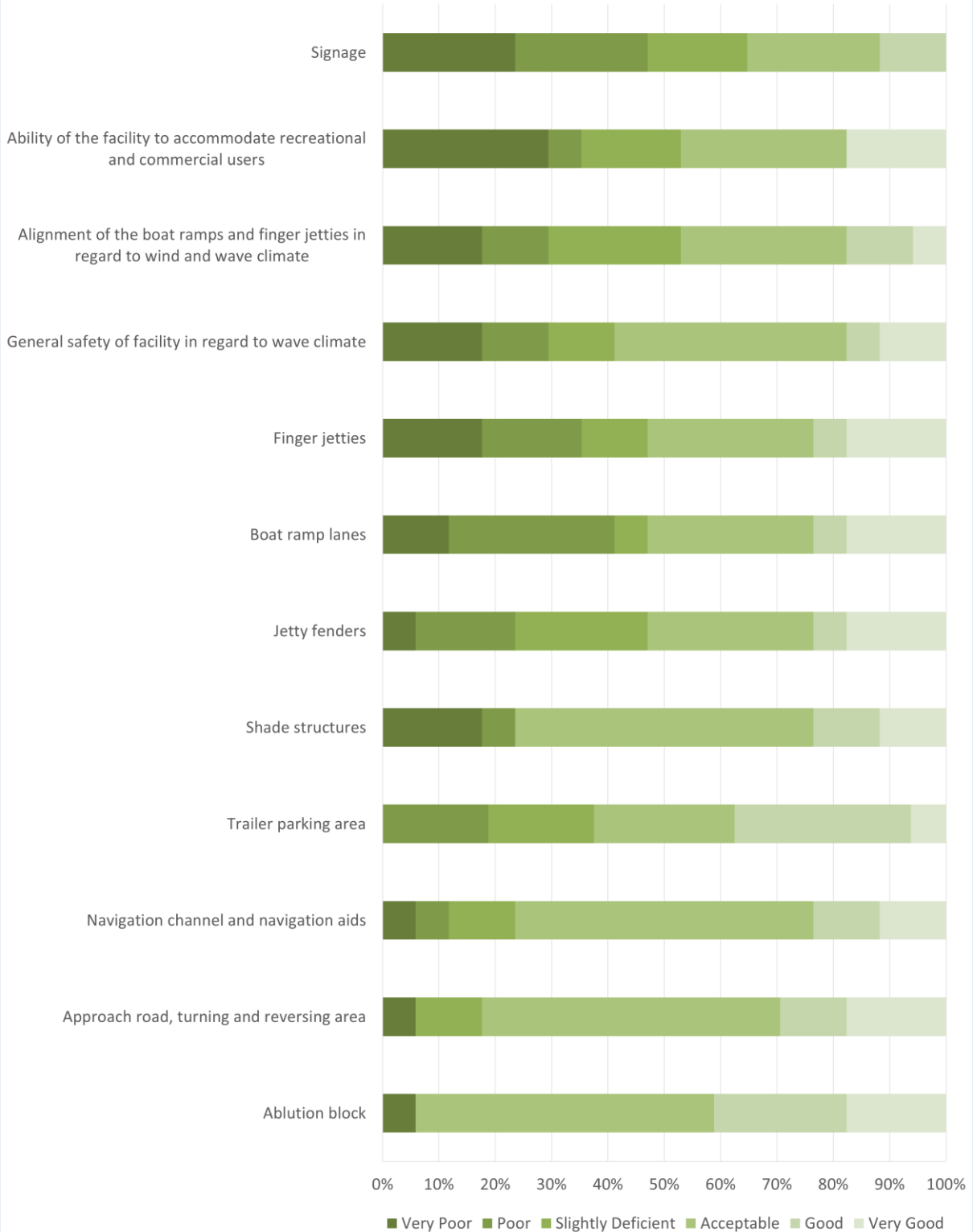
**Table 4.1 Commercial Car-park Usage**

Operators	Number of Vehicles							
	Typical Day				Peak Day			
	Cars	Cars & Trailers	Buses	Buses & Trailer	Cars	Cars & Trailers	Buses	Buses & Trailer
3 Island Whale Shark Dive	-	2	2	-	2	2	2	-
Exmouth Diving Centre	-	-	1	-	-	-	1	-
Exmouth Flyfishing	-	1	-	-	-	1	-	-
Flyfishing Frontiers	-	1	-	-	-	1	-	-
Kings Ningaloo Reef Tours	-	-	1	-	-	-	1	-
Ningaloo Blue	-	1	1	-	-	1	1	-
Ningaloo Ecology Tours	2	-	2	-	2	-	2	-
Ningaloo Pearls	3	-	1	1	4	-	1	1
Ningaloo Sportsfishing Charters	-	1	-	-	-	1	-	-
Ningaloo Whale Shark N Dive	-	1	1	-	1	1	1	-
Ocean Eco Adventures	1	1	1	-	1	1	1	-
On Strike Charters	-	1	-	-	-	2	-	-
Peak Sport Fishing	1	1	-	-	2	2	-	-
Reel Teasers Fishing Adventures	1	0	-	-	2	-	-	-
Snorkel Ningaloo	-	1	-	-	3	1	-	-
True Blue Bonefish Fishing Charters	-	1	-	-	-	1	-	-
<b>Total</b>	<b>8</b>	<b>11</b>	<b>10</b>	<b>1</b>	<b>17</b>	<b>14</b>	<b>10</b>	<b>1</b>

Notes: 1. Estimates based on information provided by commercial operators.

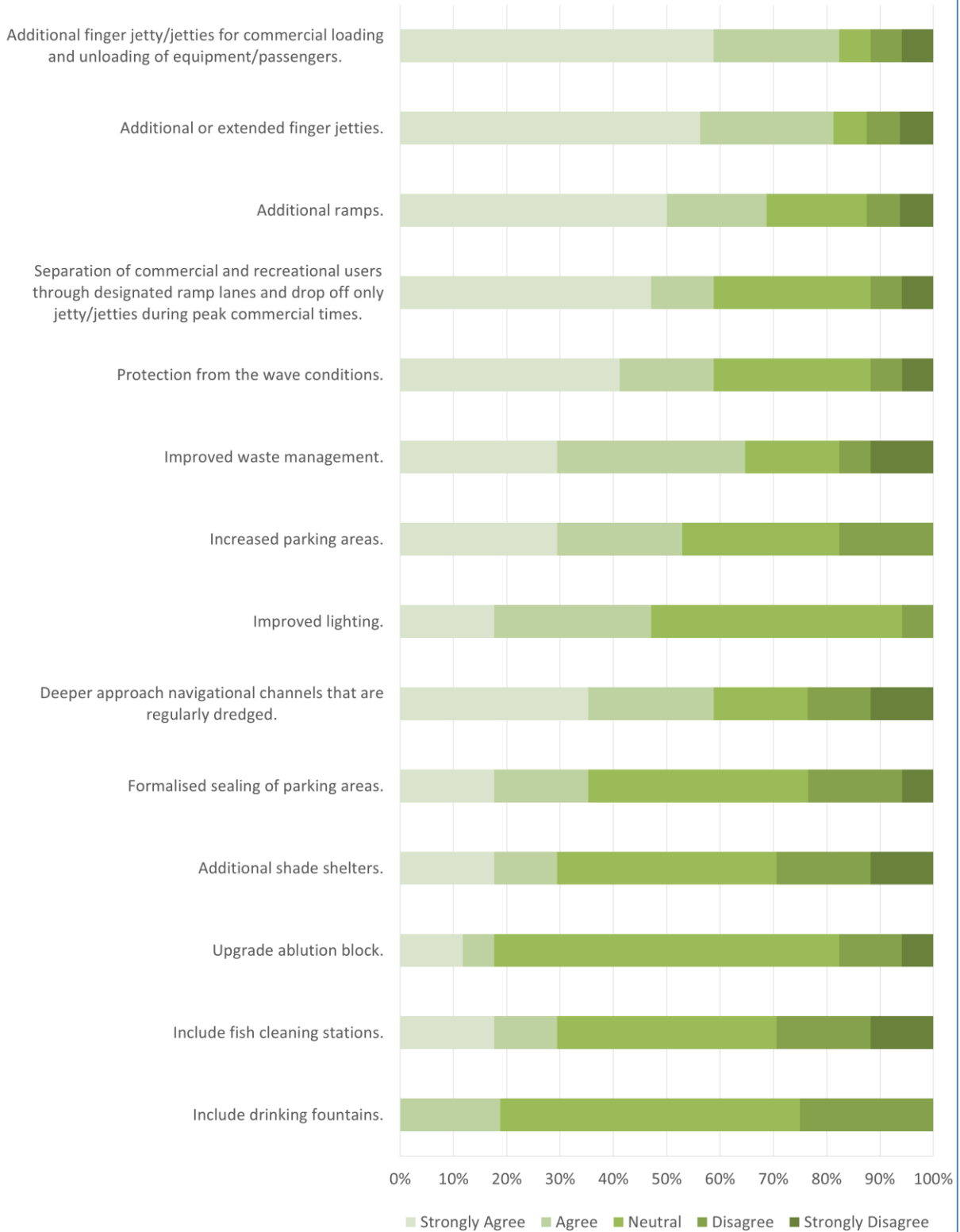
Please rate the adequacy of each of the following items at the Tantabiddi Boat Launching Facility:

Answered: 17 Skipped: 0



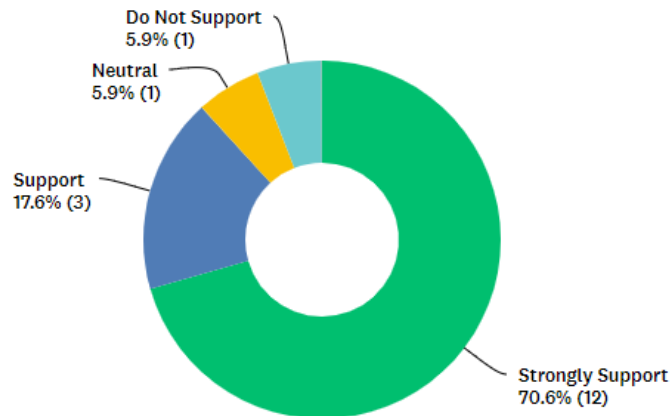
Please confirm your level of support for future upgrades to each of the following items at the Tantabiddi Boat Launching Facility:

Answered: 17 Skipped: 0



## Do you support an upgrade of the Tantabiddi Boat Launching Facility to improve it's overall functionality?

Answered: 17 Skipped: 0



As seen in the results above, there is strong support for an upgrade of the Facility by commercial operators with approximately 88% of respondents supporting or strongly supporting an upgrade. The items identified as priority future requirements to improve the user experience, safety and alleviate congestion of the Facility include the following:

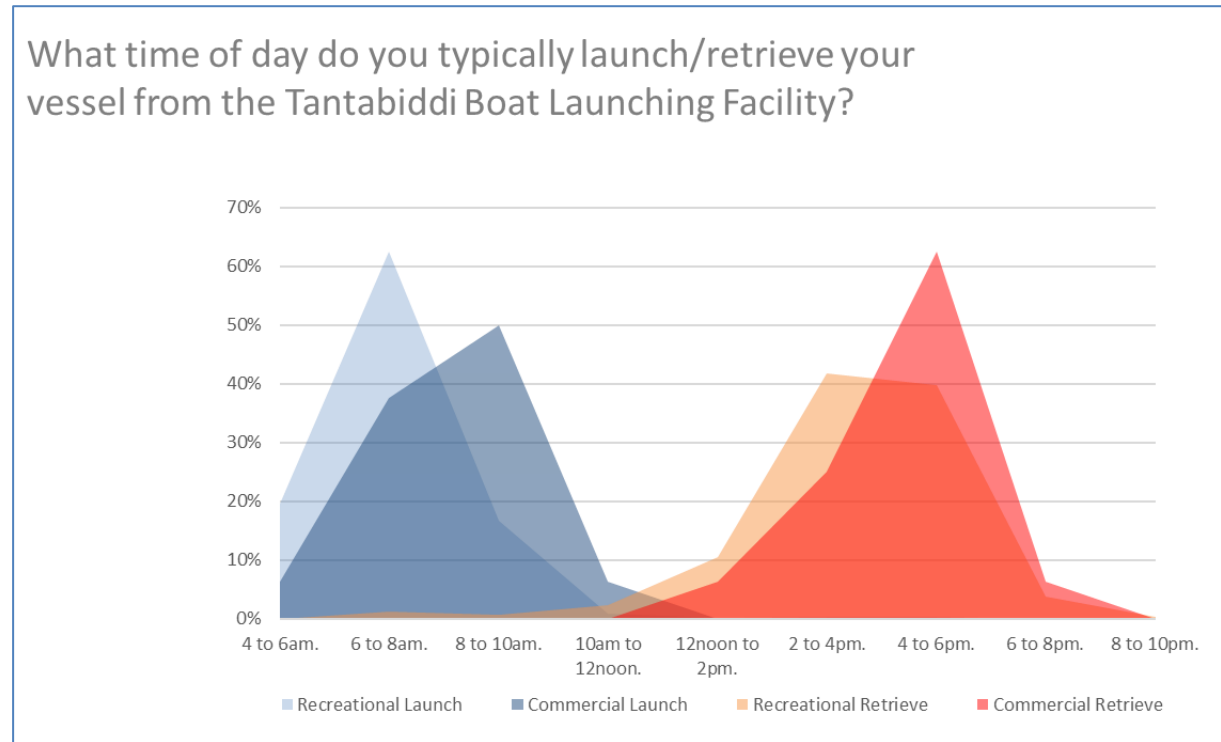
- Additional finger jetty/jetties for commercial loading and unloading of equipment/passengers.
- Additional or extended finger jetties.
- Additional ramps.
- Separation of commercial and recreational users through designated ramp lanes and drop off only jetty/jetties during peak commercial times.
- Protection from the wave conditions.
- Increased parking areas.
- Improved waste management.
- Deeper approach navigational channels that are regularly dredged.

Additional concerns raised by respondents that require consideration for future Facility requirements include the following:

- Usage instructive signage.

### 4.1.3 Combined Usage – Recreational & Commercial

Based on the results presented in the previous sections, this section identifies the busiest daily and seasonal periods of the Facility including recreational and commercial users.



As seen above, the busiest periods of the day are between 6 to 10am and 2 and 6pm. These periods are when it's most likely for potential conflicts to occur.

The busiest times of the year have been identified as between March and October.

## 4.2 Traffic Counter Assessment

Traffic counters are an effective way of assessing the usage of the Facility by recording each time a vehicle passes over the instrument. DBCA has historically managed a traffic counter that was installed at the entrance to the Facility, adjacent to Yardie Creek Road. As a part of this investigation, MRA installed a traffic counter at the entrance to the turning area at the western end of the car-park. The approximate locations of the traffic counters are shown in the following figure.



**Figure 4.5 Traffic Counter Locations**

The duration of data available for the assessment for the two traffic counters is presented in the following table.

**Table 4.2 Traffic Counter Data**

Traffic Counter	Deployment Period
MRA Managed	21 February 2018 to 22 April 2018 <sup>1</sup>
DBCA Managed	January 2011 to April 2018 <sup>2</sup>

Notes: 1. No gaps exist in the data during the deployment period of MRA's Traffic Counter.  
 2. There are gaps that exist in the data during the deployment period of DBCA's Traffic Counter.

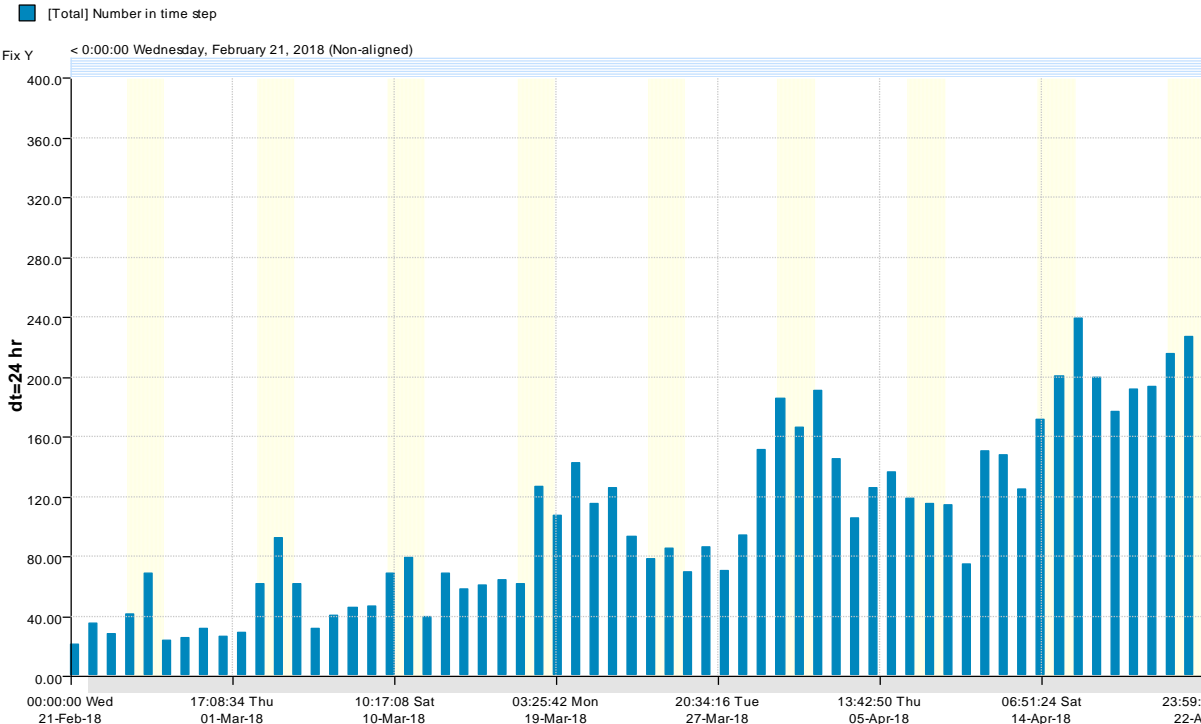
The traffic counters attempt to estimate quantities of the different vehicle types entering each of the facilities over the periods.

MRA's traffic counter was installed to confirm the adequacy of the DBCA data set and to measure the traffic flow between of the car-park and the boat ramp. The ARX Classification System defined in MetroCount (2009) was used to analyse the data sets.

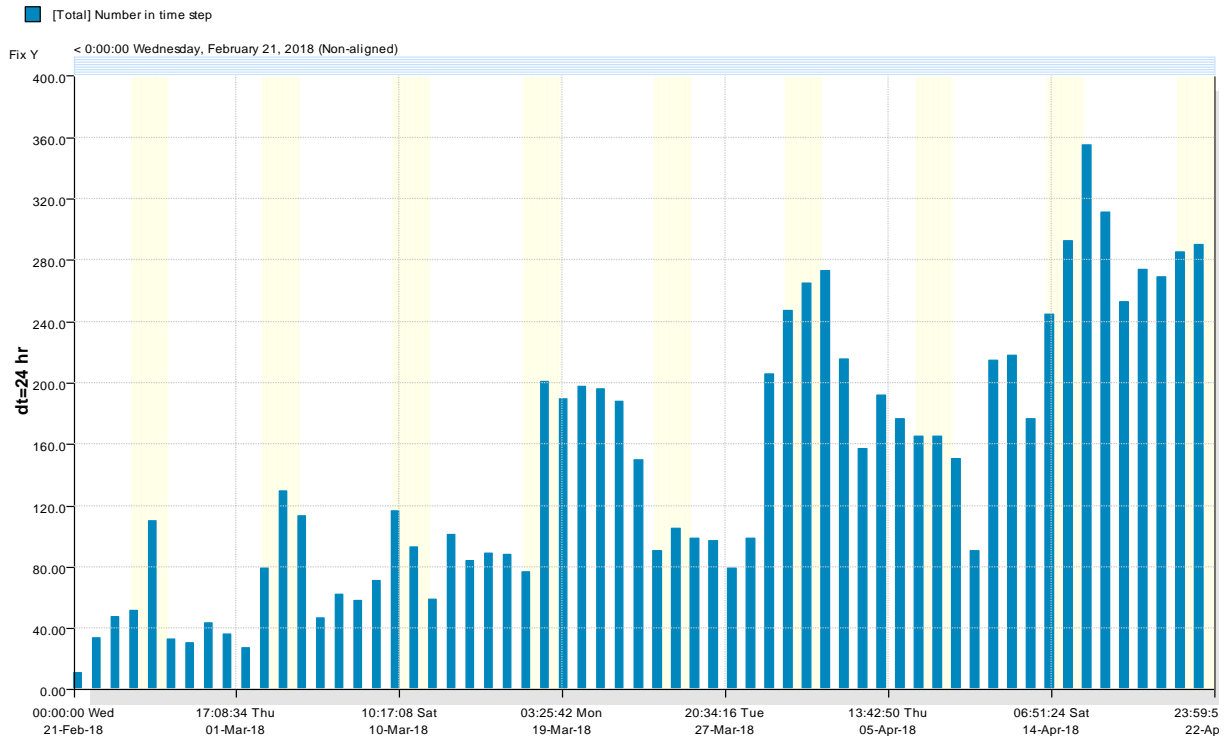
As a part of the assessment, the vehicle counts recorded by the traffic counters were compared against the vehicle count of the car park during the site inspection presented previously in Table 3.3. The comparison showed that there were some discrepancies regarding the separation of the vehicle counts into the vehicle classification schemes. Therefore, the vehicle class data for the traffic counters needs to be assessed with caution.

It has been assumed that the traffic counters provide a reasonable estimate of the total number of vehicles using the Facility. Therefore, the total number of vehicles counts have been examined in more detail as a part of this investigation.

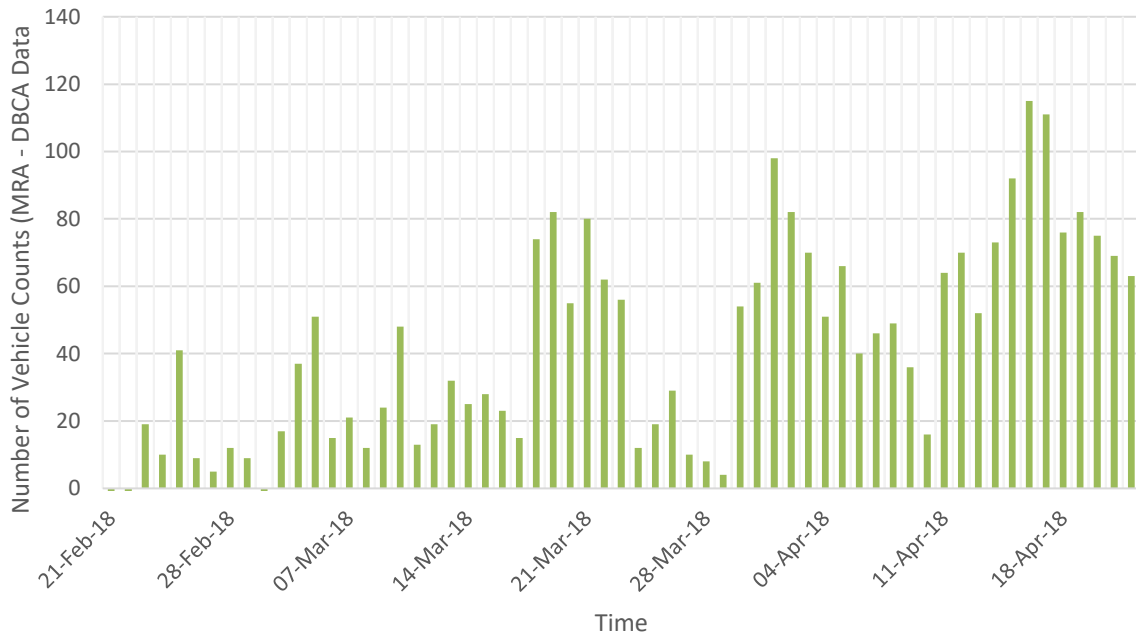
A comparison of the data has been completed for the data sets over the period from 21 February 2018 to 22 April 2018. The data was assessed as the number of vehicles crossing the traffic counters in an east to west direction. The data recorded by the DBCA counter and MRA counter is presented in Figures 4.6 and 4.7 respectively. The difference between the number of vehicles entering the car-park (DBCA counter) and the boat ramp (MRA counter) can be seen in Figure 4.8.



**Figure 4.6 DBCA Data – Number of Vehicles Entering Facility Per Day**



**Figure 4.7 MRA Data – Number of Vehicles Entering Boat Ramp Per Day**



**Figure 4.8 Difference Between Vehicle Counts (MRA – DBCA Data)**

As seen in the figures above, the number of vehicle counts crossing MRA’s traffic counter was typically higher than the number of vehicle counts crossing DBCA’s traffic counter. This can be explained by the following:

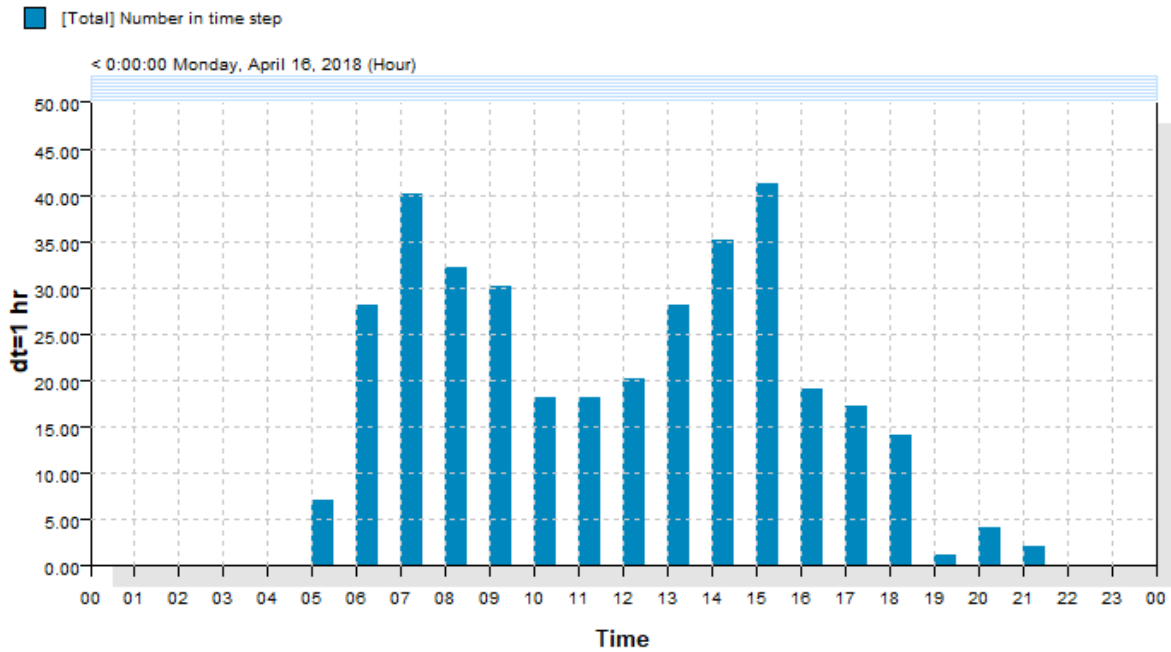
- Cars with trailers launching vessels, will typically drive to the ramp to launch the vessel, then park in the car park and then return to the ramp to retrieve the vessel (therefore registering 2 vehicle counts in the east to west direction over MRA's traffic counter).
- Buses often drop off passengers at the boat ramp turning area, then park in the car park and then pick up passengers at the ramp (therefore registering 2 vehicle counts in the east to west direction over MRA's traffic counter).

It has been assumed that there is a small portion of the number of vehicles that would cross DBCA's traffic counter and not MRA's traffic counter.

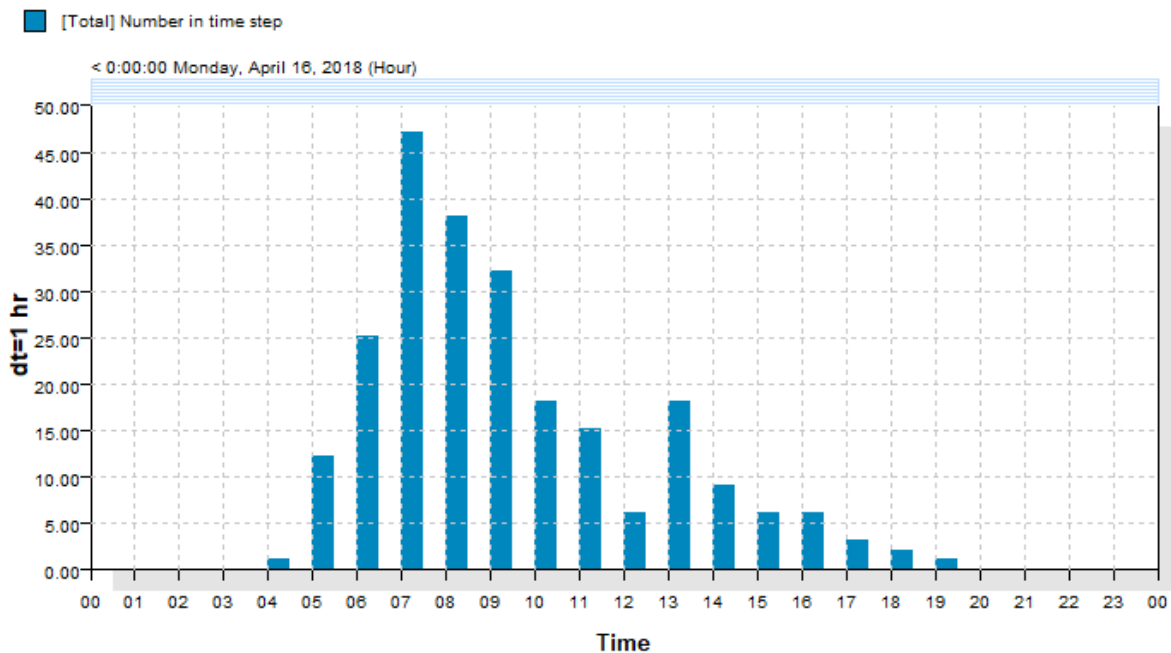
It is understood that the usage of the Facility to launch and retrieve vessels is likely to be highly influenced by the weather conditions experienced. Given the commercial benefits associated with uninterrupted usage of the Facility (regardless of the weather), it has been assumed that commercial operators would operate under the majority of conditions. The use of the Facility by recreational users is more likely to be weather dependent than use of the Facility by commercial operators. Therefore, the peak usage days are likely to be days where good weather conditions are experienced. On days of good weather, a larger proportion of recreational users compared to commercial users would be expected.

Based on the data over this period, the difference between the numbers of vehicle counts between each of the traffic counters varies but reaches between 100 and 120 on peak use days. As outlined above these values represent either buses dropping off and then picking up passengers near the boat ramp or vessels being launched and retrieved. For the purposes of this investigation, the peak usage days have been used to guide the future requirements of the Facility discussed in Section 5.

The peak usage day recorded by both traffic counters was Monday 16 April 2018 during the school holidays. The difference between the number of vehicles entering the car-park and the boat ramp on an hourly basis can be seen in Figures 4.9 and 4.10 respectively.



**Figure 4.9 MRA Data – Number of Vehicles Entering Boat Ramp Per Hour (16 April 2018)**



**Figure 4.10 DBCA Data – Number of Vehicles Entering Facility Per Hour (16 April 2018)**

It is noted that the typical launching and retrieve times provided by the recreational and commercial respondents in the online survey generally match the vehicle activity shown on Figure 4.9. This confirms that the online survey results are a good representation of reality.

The following table provides an estimate of the breakdown of the number vehicles on the 16 April 2018. It has been assumed that the number of commercial operators and associated vehicle distribution present during the site inspection on the 23 April 2018 were also present on the

16 April 2018. This has then been applied to the total number of vehicle counts to estimate the number of vessels utilising the Facility on this peak day.

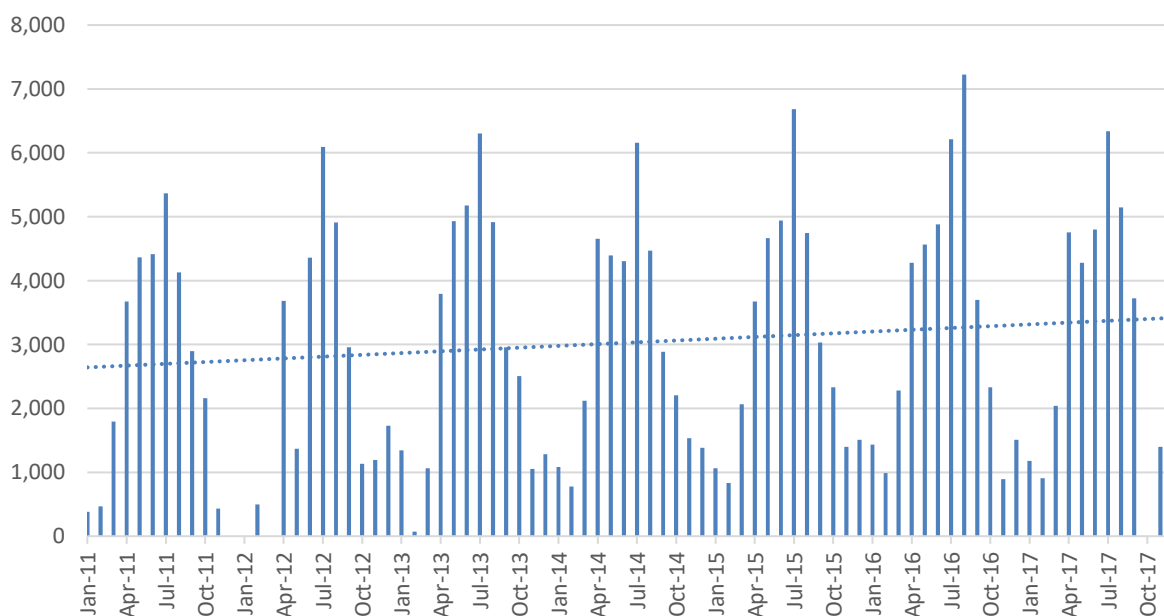
**Table 4.3 Vehicle Estimates on 16 April 2018**

Difference Total	Number of Vehicle Counts (Estimated)	
	Buses	Trailerred Vessels
115	12	103

Based on the information received for the peak usage times of the year for both commercial and recreational users, April is the start of the peak season and can be used as a good representation of the ramp usage. As shown in Table 4.3, approximately 103 trailerred vessels utilised the Facility on the 16 April 2018. This estimate is a combination of recreational and commercial vessels and represents approximately 45% of the total number of vehicle counts recorded by DBCA’s traffic counter.

These values are consistent with a snapshot analysis of a historical aerial image from Sunday 7<sup>th</sup> September 2013 reviewed through Landgate’s online portal.

The following figure presents the number of vehicles crossing DBCA’s Traffic Counter per month over the duration of the data record. MRA extracted the November and December 2017 using the same methodology as DBCA. It is noted that there are gaps within this data set and the trendline presented on the figure can only be used as a general trend of the data set.



**Figure 4.11 Total Number of Vehicles Entering the Facility Per Month**

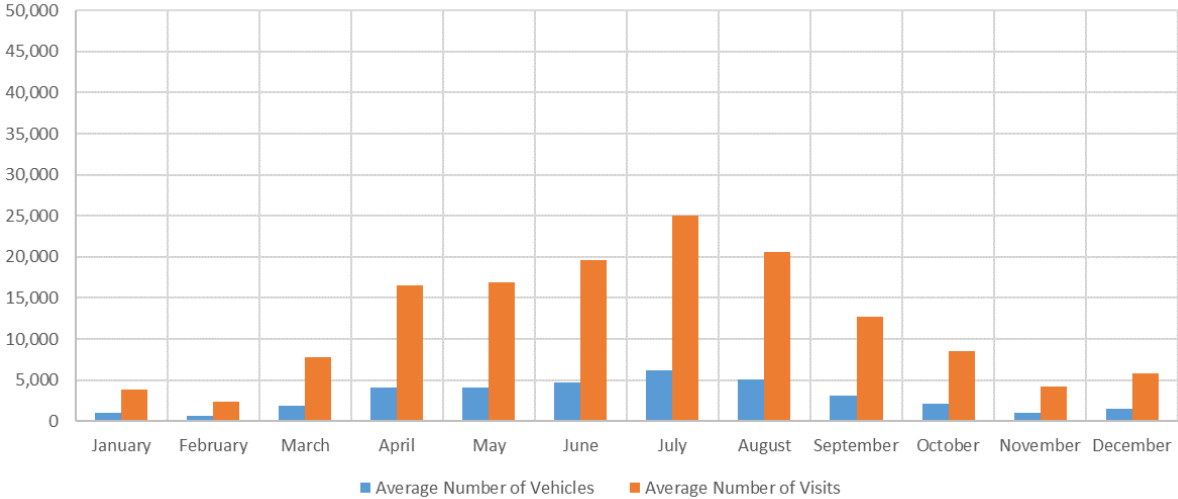
Figure 4.11 shows that there has been a steady increase in the number of vehicles visiting the Facility between 2011 and 2017.

The number of trailered vessels that currently utilise the facility on a peak day has been estimated to be approximately 100 to 120. Historically, this number has been increasing by approximately 4% per year.

The DBCA has also completed an analysis on the number of visits to the Facility. The data presented in the following figure was extracted, analysed and provided by DBCA. The data represents the number of ‘visits’ rather than ‘visitors’. A visit is defined by Hornback, K.E. and Eagles, P.F.J. (1999):

*“measurement unit involving a person going onto lands and waters of a park or protected area for the purposes mandated for the area. Each visitor who enters a park for a purpose mandated for the area creates a visit statistic. Typically, the visit statistic has no length of stay data associated with it. This definition of a visit means that if a person leaves the park and re-enters at a later time, then a second visit data unit is recorded”.*

The DBCA data is input into the database by district staff based on vehicles entering site only (to avoid double counting) and multiplied by average passenger per vehicle (PPV) figures for vehicle class groupings based on monitoring or tour operator data. The data was extracted using the ARX vehicle classification scheme.

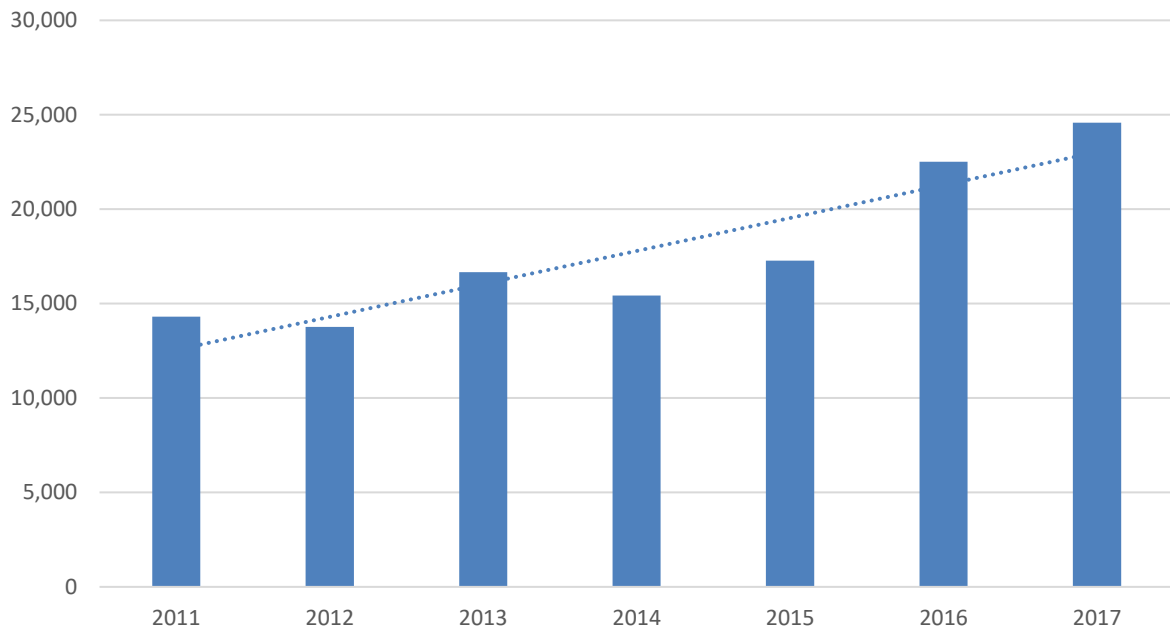


**Figure 4.12 Average Number of Vehicles & Visits – 2011 to 2017 (DBCA, 2017)**

The data presented in Figure 4.12 confirms the peak season period of March to October identified in previous sections. Given the general increases experienced over the period of the data, it is estimate that up to approximately 25,000 to 30,000 people have historically visited the Facility during the peak month of the year (being July).

### 4.3 Whale Shark Tour Participants

The DBCA keeps records of the number of whale shark tour participants. The DBCA provided the number of whale shark tour participants between 2011 and 2017, this information is presented in the following figure.

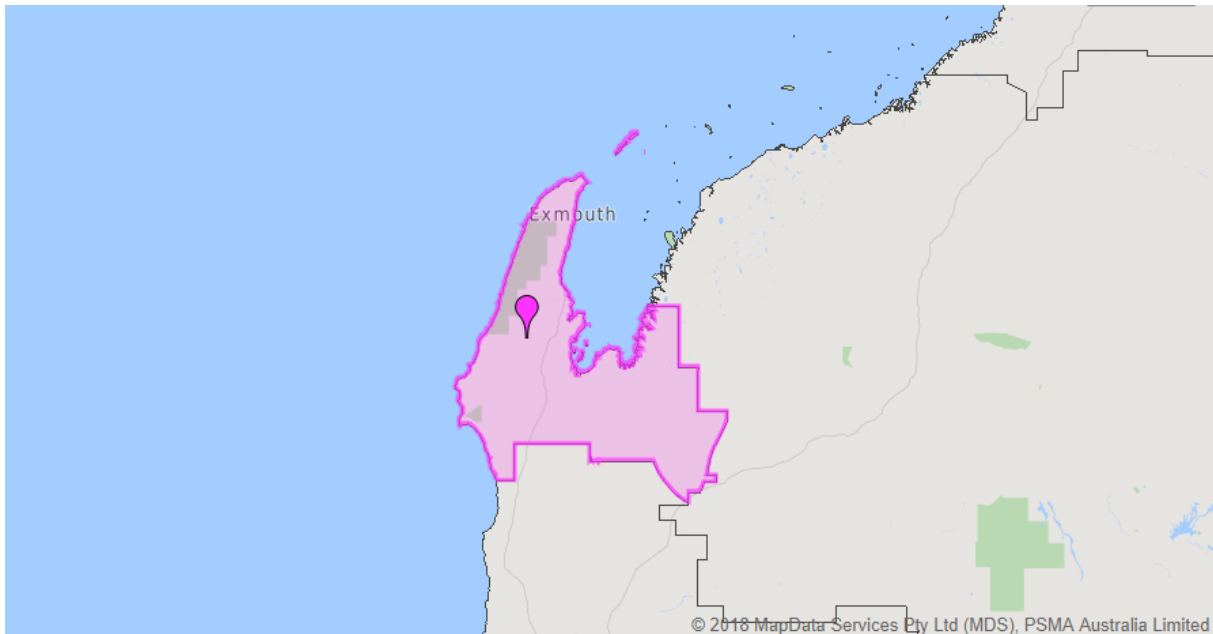


**Figure 4.13 Number of Whale Shark Tour Participants (DBCA 2017)**

Figure 4.13 shows that there has been a large increase in the number of whale shark tour participants between 2011 and 2017. These account for a large proportion of the commercial users of the Facility.

## 4.4 Recreational Boat Registration Data & Trends

As previously mentioned, the Facility is used by both visitor and residential recreational boat users. This has been taken into account when assessing the recreational boat registration trends. For the purpose of this investigation, visitor usage trends have been assessed using data for Western Australia as a whole, while residential usage trends have been assessed using data for the Exmouth Region. The extent used for the Exmouth Region is shown in the following figure.



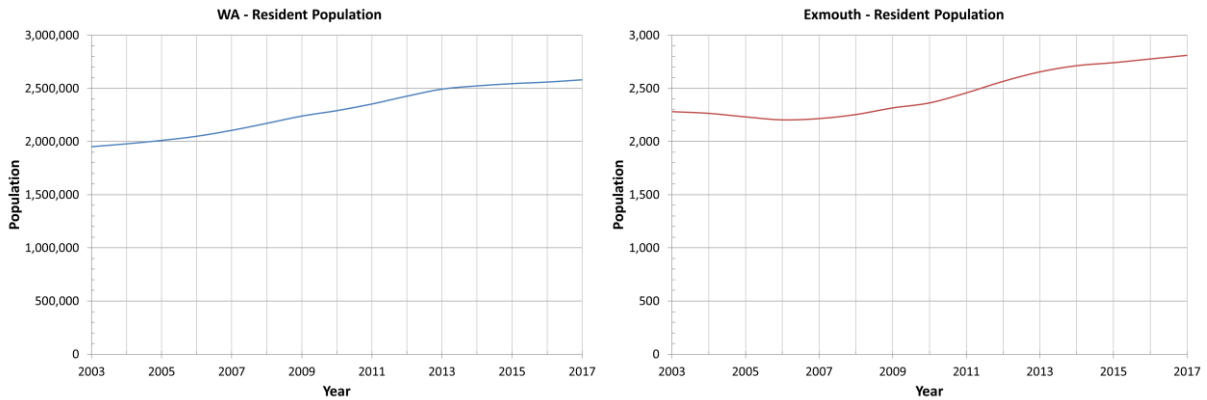
**Figure 4.14 Exmouth Region (ABS 2018)**

### 4.4.1 Data

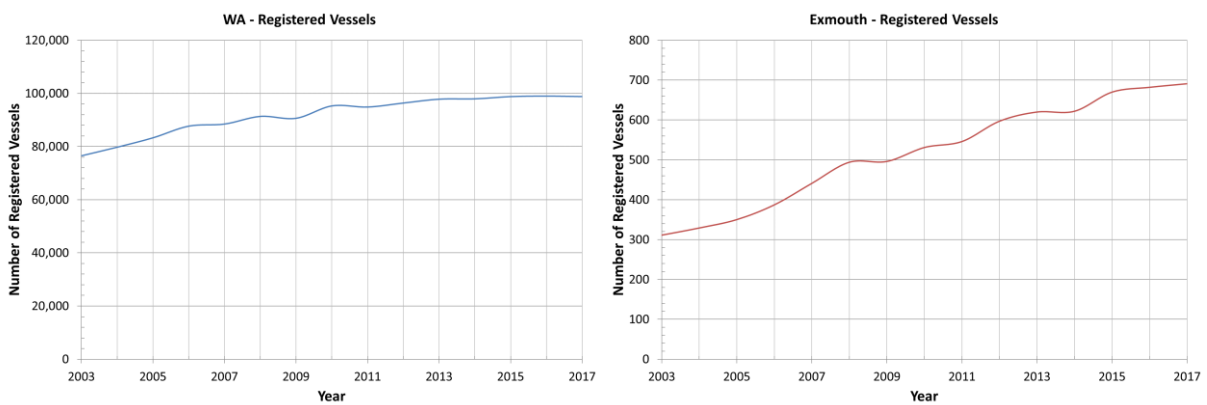
Information with respect to the local population per statistical area has been provided by the Australia Bureau of Statistics (ABS) and the Shire and is presented in Figure 4.15.

Information with respect to vessel registration has been provided by the Department of Transport (DoT) and is presented in Figure 4.16. This data includes vessels of all lengths. Based on a review of historical aerial images, approximately 60 to 70 vessels within the Exmouth Marina and associated canals have been assumed to be registered within the Exmouth Region and would not regularly use the Facility. These vessels would account for approximately 10% of the number of vessels shown in Figure 4.15. Therefore, the number of vessels registered within Exmouth that are likely to use the Facility is approximately 90%.

This percentage does not account for vessels that commonly utilise other Boat Launching Facilities in the area, such as Bundegi. Based on the results of the online recreational boat users survey, approximately 5% of residents that responded to the survey stated that they utilised the Facility less than once a year. It has therefore been assumed that this percentage of resident boat owners rarely use the Facility. Therefore, the total percentage of the number of vessels registered within Exmouth that are likely to use the Facility has been assumed to be approximately 85%. This has been used to guide the future requirements of the Facility discussed in Section 5.



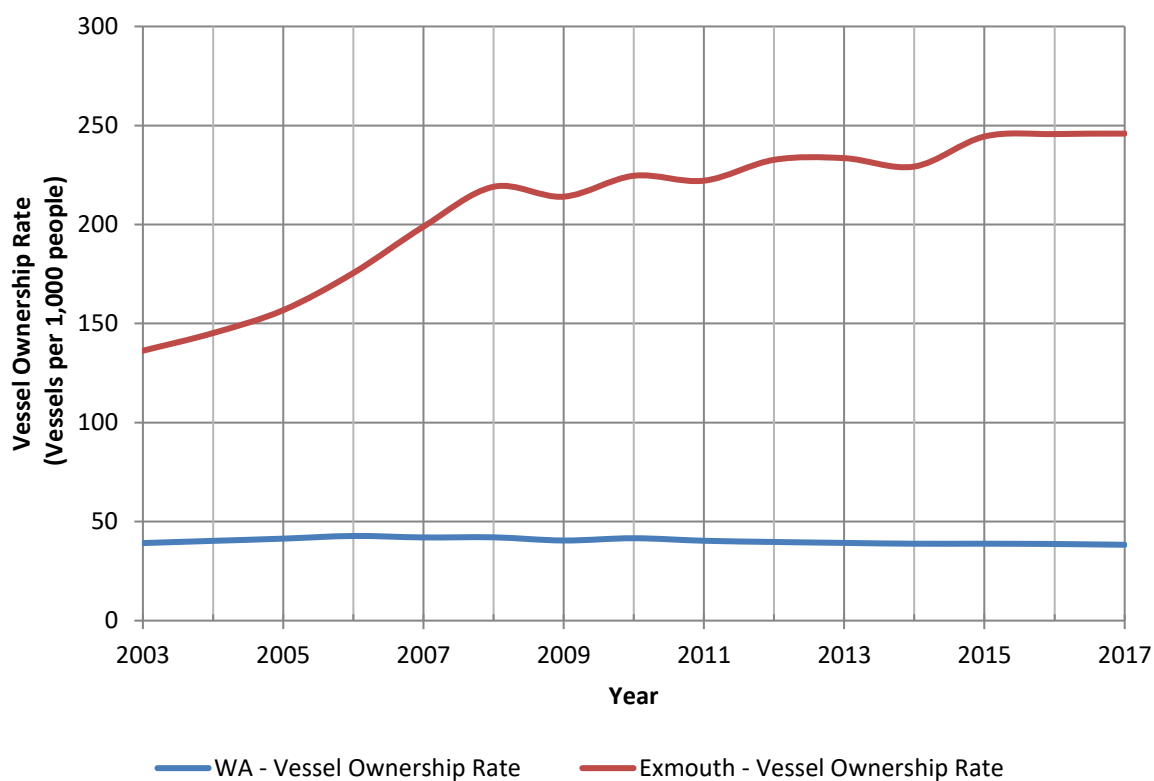
**Figure 4.15 Historical Population**



**Figure 4.16 Registered Vessels**

#### 4.4.2 Historical Vessel Ownership Rates

Based on the population and vessel registration data presented in the preceding section, an assessment of the rate of vessel ownership has been made. This compares the resident population of Western Australia and the Exmouth Region with the number of registered vessels in Western Australia and the Exmouth Region. This data is commonly expressed in terms of registered vessels per thousand people. This analysis has been presented in the following figure.



**Figure 4.17 Vessel Ownership Rates**

For Western Australia, the vessel ownership rate peaked at approximately 43 vessels per thousand people in the 2006 and has steadily decreased to around 38 vessels per thousand people in 2017.

For the Exmouth Region, whilst there has been an overall increase in the rate of vessel ownership from around 136 vessels per thousand people in 2003 to around 246 vessels per thousand people in 2017, this growth was comprised of three different trends. These are described as follows.

- Prior to 2009 – historically there was a sharp increase in the number of vessels per thousand people of up to 20 boats per thousand people per year.
- 2009 to 2015 – there has been a steady increase of approximately 3 vessels per thousand people per year.
- 2015 to 2017 – there appears to be a plateau in the number of vessels per thousand people. It appears that a saturation limit may be beginning to be reached of approximately 250 vessels per thousand people.

As a comparison, the following table presents the historical vessel ownership rates for other regions of Western Australia.

**Table 4.4 Historic Vessel Ownership Rates – Other Regions**

Region	Historical Rate & Date
Shire of Roebourne	152 / 1,000 people @ 2010
Port Hedland	77 / 1,000 people @ 2010
Broome	95 / 1,000 people @ 2011
Perth Metropolitan	32 / 1,000 people @ 2008
Peel Region	102 / 1,000 people @ 2009
City of Busselton	101 / 1,000 people @ 2011

Notes: 1. Data taken from DPI, 2008. DoT, 2011. DoT, 2010. DoT, 2012. MRA, 2013 & MRA 2016.

This shows that Exmouth has one of the highest boat ownership rates with approximately 1 in every 4 people owning a boat.

#### 4.5 Data Assessment Summary

A significant amount of data has been collected and analysed as a part of this investigation. The key findings from the data assessment are outlined in the following table.

**Table 4.5 Summary of Current Facility Usage in 2018**

Users of Facility	Peak Season (March to October) Day Type	Total Number	Approximate Percentage Usage	
			Commercial	Recreational
Vehicles	Average Day	150 to 200	85%	15%
	Peak Day	250 to 350	65%	35%
Vessels	Average Day	30 to 40	30%	70%
	Peak Day	100 to 125	12%	88%
Passengers	Average Day	200 to 250 <sup>1</sup>	70%	30%
	Peak Day	500 to 600 <sup>1</sup>	60%	40%
Weighted Average <sup>2</sup>	Average Day	N/A	62%	38%
	Peak Day	N/A	46%	54%

Notes: 1. Estimate of recreational passengers is based on the assumption that an average of 2 people are aboard every recreational vessel.

2. Weighted Average has been estimated as equal thirds of vehicles', vessels' and passengers' approximate percentage usages.

It has been assumed that the northern side of the north jetty is only used by commercial users. The percentage usages breakups presented in Table 4.5 does not include the use of this component of the Facility. This usage is therefore likely to add additional percentage usage to the commercial users during the peak season. The percentage breakup of Facility usage on average during the peak season is likely to be approximately 55% commercial and 45% recreational users.

It is assumed that during the off season (November to February) the Facility is primarily used by recreational users. This period represents one third of the year by time duration but only 10% of the year by proportion of the average number of visitors. Therefore, as an estimate of the entire year, percentage breakup of Facility usage on average is likely to be approximately 50% commercial and 50% recreational users for the current day scenario.

Given that commercial and recreational activity is likely to increase at a similar rate to that of the number of visitors in the region, this current percentage breakup of 50% commercial and 50% recreational has been used in the projections of future Facility usage to 2038 discussed in Section 5.

The capacity of a single boat ramp lane with a holding structure has been assumed to be 50 vessels per day. This estimate has previously been used in boating demand studies such as MRA (2016) and is based on the requirements of the Australian Standard AS3962. Based on the estimated 100 to 125 trailered vessels currently utilising the 2 boat ramp lanes on peak days during the peak season, the existing Facility is currently over capacity during these periods. This over congestion is exacerbated under certain conditions when sedimentation of the southern ramp lane results in the majority of vessels having to use the one northern ramp lane.

## 5. Future Demand & Requirements

### 5.1 Projections

Population and vessel ownership projections have been used to assess the requirements for the future use of the Facility.

#### 5.1.1 Population Projections

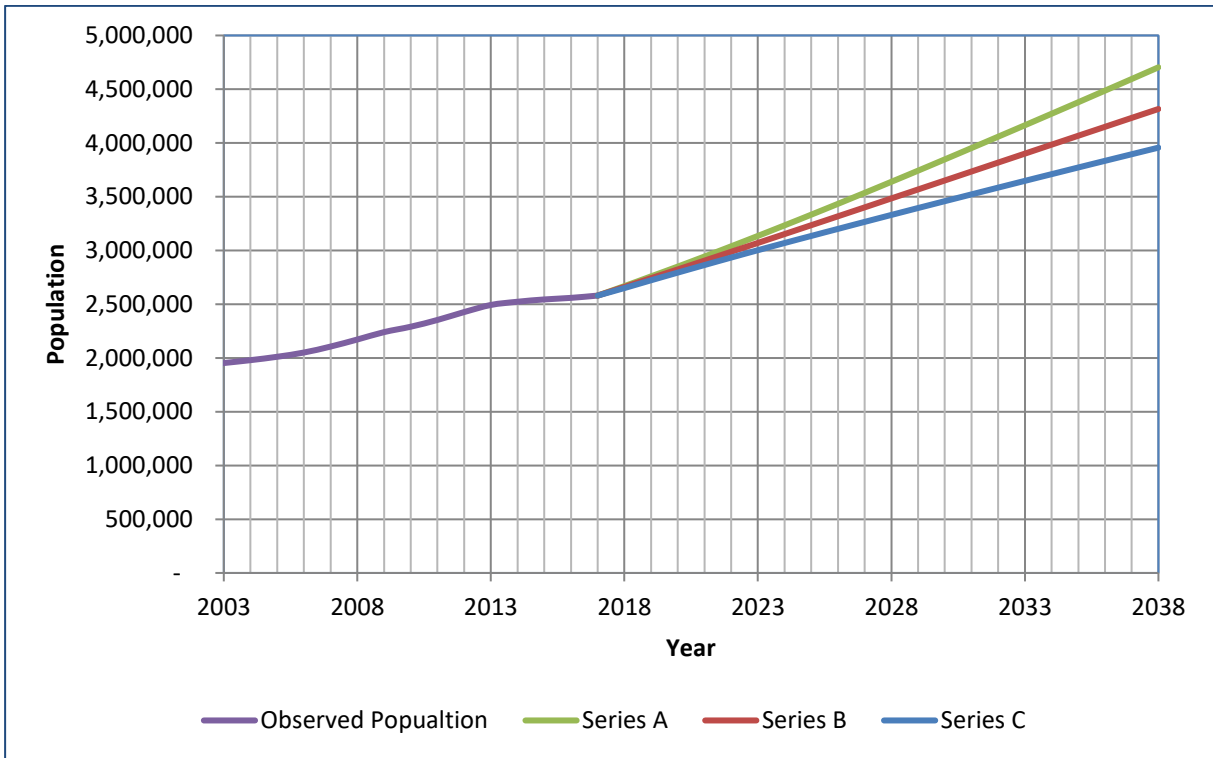
The projected population increase rates for Western Australia and Exmouth have been taken from ABS (2012) and Shire (2012) and are presented in the following table.

**Table 5.1 Projected Annual Population Growth Rates**

Item	WA	Exmouth Residents	Exmouth Visitors
1	Series C 3.3% in 2012 to 1.5% in 2038	Medium 0.6%	'2 year Growth' 5.5% in 2018 to 2.6% in 2038
2	Series B 3.4% in 2012 to 1.8% in 2038	High 1.7%	'4 year Growth' 26% in 2018 to 4.3% in 2038
3	Series A 3.6% in 2012 to 2.2% in 2038	Aspirational 6.3%	N/A

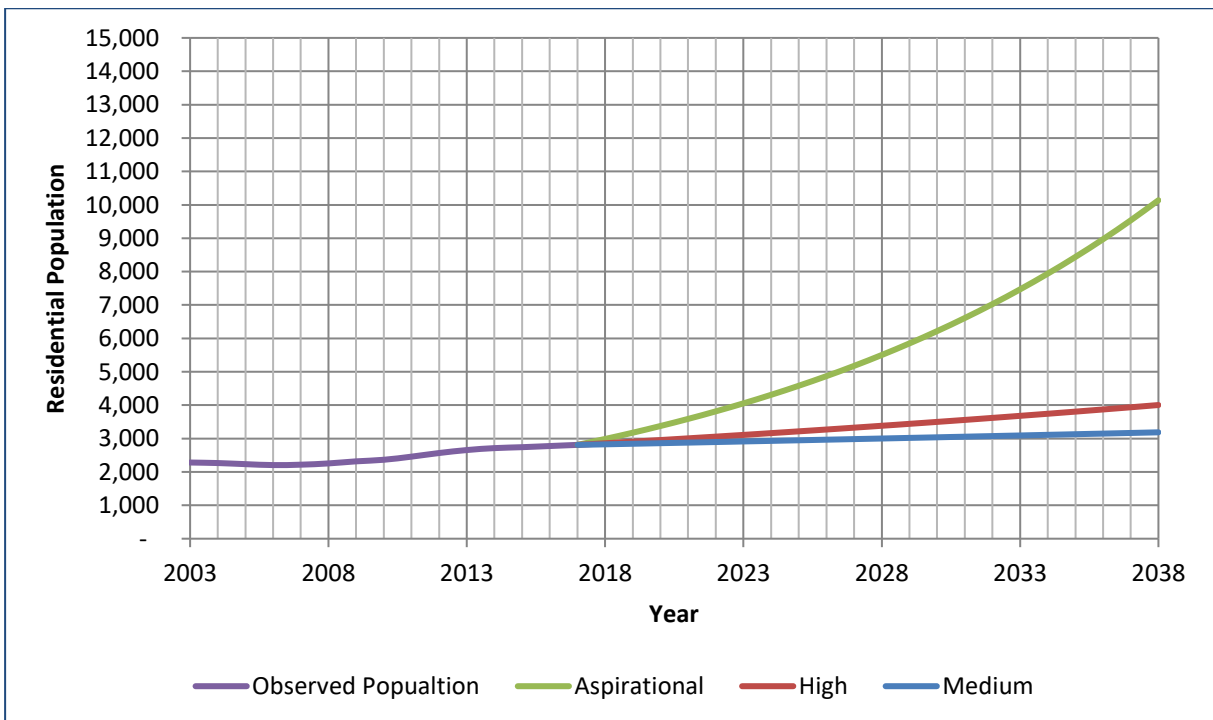
The different series (A, B & C and Aspirational, High and Medium) represent upper, mid and lower projection estimates. The '2 year Growth' and '4-year Growth' rates are historically experienced rates that have been projected forward over the planning timeframes.

Given the projections were made from a base year of 2012, for the purposes of this assessment the observed population changes between 2012 and 2017 have been included and the projection rates reapplied to start from 2018. The projected populations for Western Australia used in this assessment are presented in the following figure.



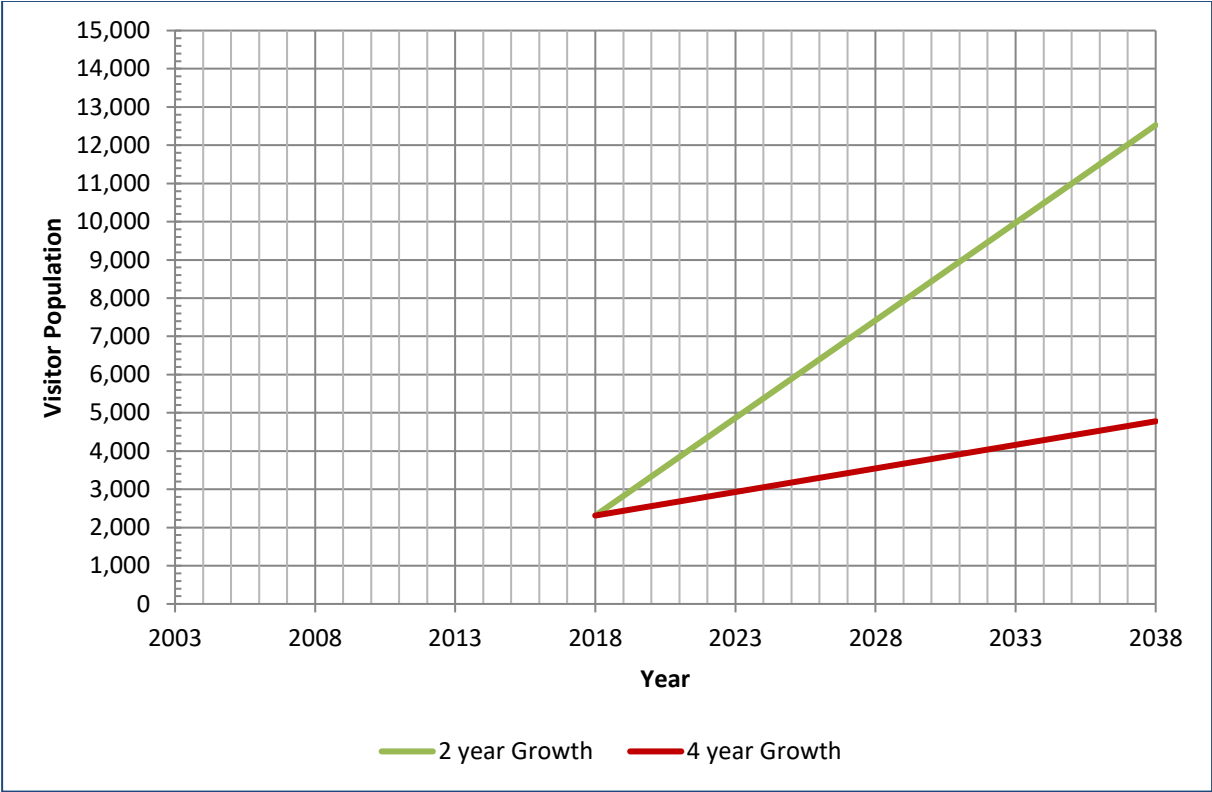
**Figure 5.1 Projected Population – Western Australia**

Given that Exmouth has a significant number of tourists that utilise the Facility, projected populations have been assessed for residents and visitors. The projected populations for Exmouth Residents used in this assessment are presented in the following figure.



**Figure 5.2 Projected Population – Exmouth Residents**

The projected populations for Exmouth Visitors have been taken from Shire (2012). No record of the historical observed tourist population estimates has been made available and is unable to be presented. The projected population of Exmouth Visitors used in this assessment are presented in the following figure.



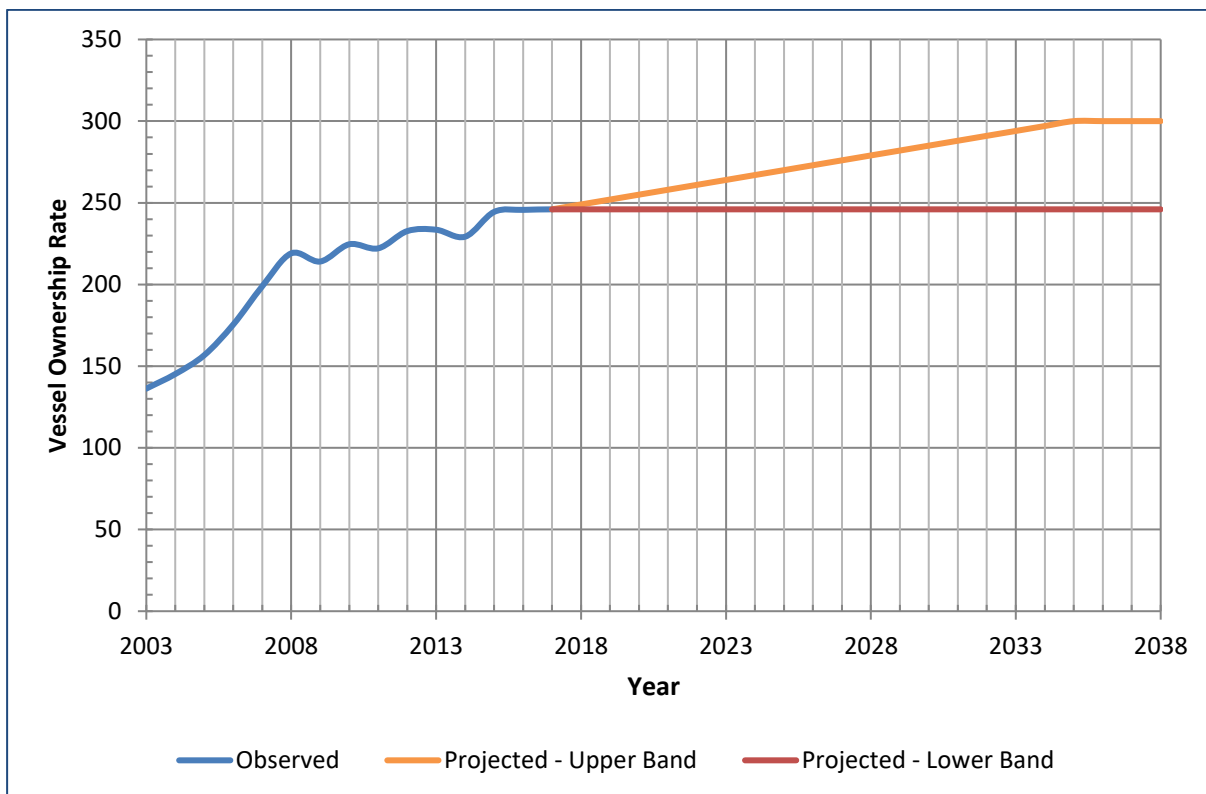
**Figure 5.3 Projected Population – Exmouth Visitors**

This investigation has considered all of the population growth scenarios presented above, which range from modest increases in population to significant changes in the number of residents and visitors to the Exmouth Region.

**5.1.2 Vessel Ownership Projections**

As described in the previous section, the Exmouth Region vessel ownership rate has increased at a steady rate since 2008 and may be approaching a saturation point. However, based on the assumption that the facility may be improved/upgraded following recommendations of this investigation, this rate may still increase over the coming years.

Two scenarios are presented in the following figure, where the vessel ownership rate plateaus at around 250 vessels per 1,000 people or continues to increase to around 300 vessels per 1,000 people by the mid-2030s. Given a large portion of the population are unlikely to own vessels or they share vessels with other family members (e.g. children) or friends an upper limit of 300 is considered appropriate.



**Figure 5.4 Vessel Ownership Rate Projections – Exmouth**

As a comparison, the following table provides historical and predicted vessel ownership rates for other regions around Western Australia.

**Table 5.2 Historic and Predicted Vessel Ownership Rates – Other Regions**

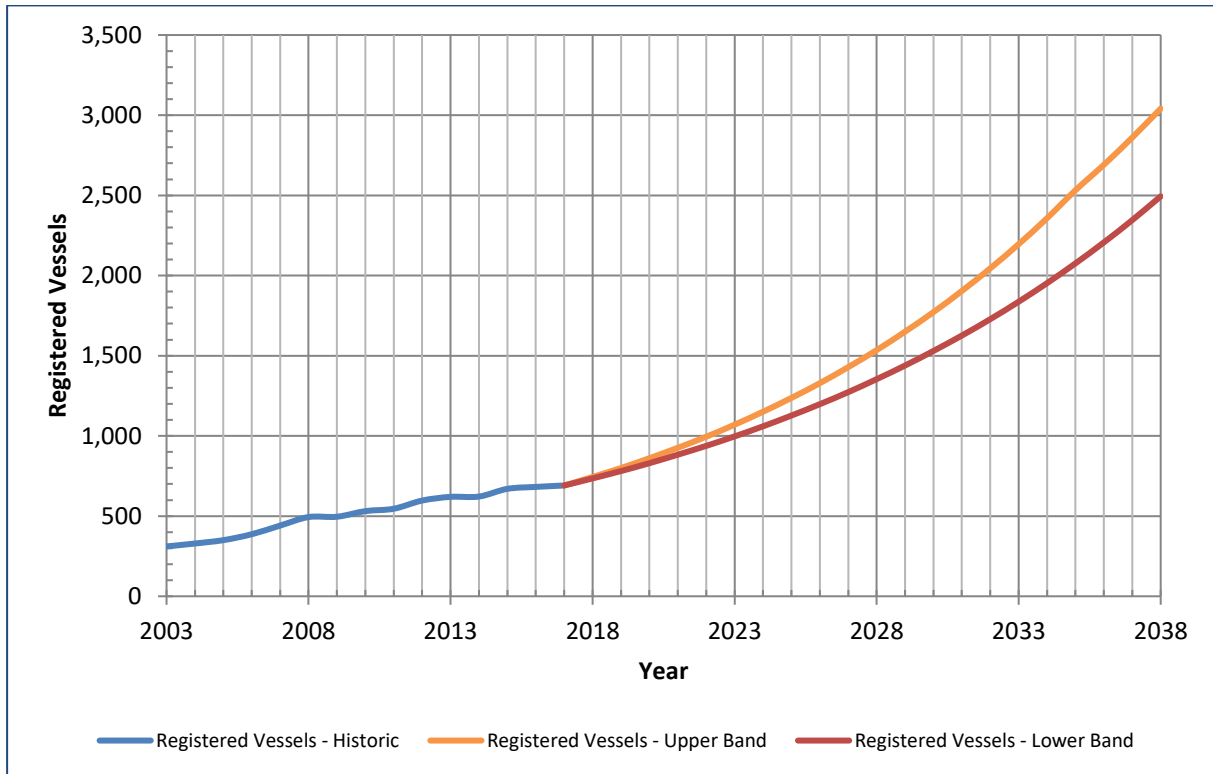
Region	Historical Rate & Date	Predicted Rate & Date
Shire of Roebourne	152 / 1,000 people @ 2010	N/A
Port Hedland	67 / 1,000 people @ 2015	110 / 1,000 people @ 2035 (Upper Saturation Limit)
Broome	95 / 1,000 people @ 2011	167 / 1,000 people @ 2031
Perth Metropolitan	32 / 1,000 people @ 2008	43 / 1,000 people @ 2025
Peel Region	102 / 1,000 people @ 2009	121 / 1,000 people @ 2031
City of Busselton	101 / 1,000 people @ 2011	N/A

Note:

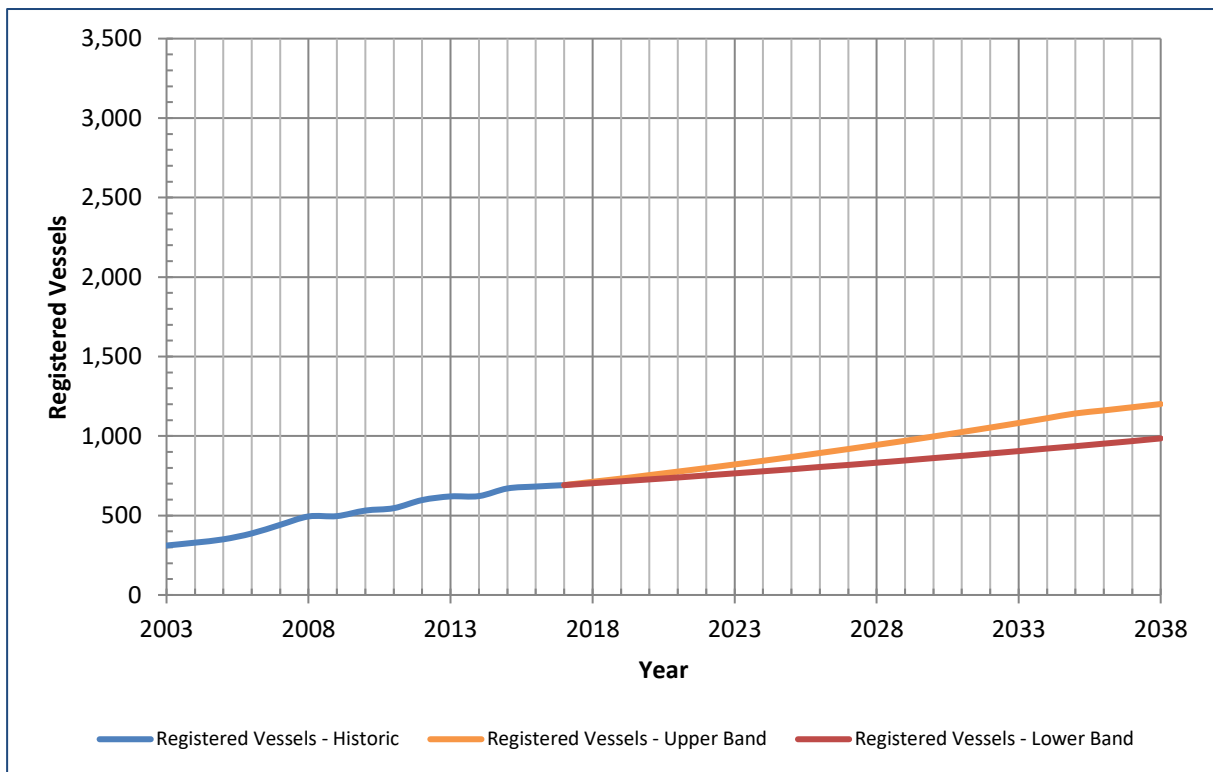
1. Data taken from DPI, 2008. DoT, 2011. DoT, 2010. DoT, 2012. MRA, 2013 & MRA 2016.

Based on the methodology presented in the preceding section, an assessment of the total number of registered vessels in Exmouth to the year 2038 has been completed and is presented in the following figures. It should be noted that these projections represent an average boat ownership rate that could be expected over the longer term. Fluctuations in the actual rates of boat

ownership, such as those observed between 2003 and 2017, are still expected to occur in the future and are expected to be driven by economic factors and other unknowns.



**Figure 5.5 Exmouth Projected Registered Vessels – Aspirational Growth**



**Figure 5.6 Exmouth Projected Registered Vessels – High Growth**

It is unlikely that all vessels in the area will be in use at any one time. Therefore, in order to determine the demand for recreational boat ramps an assessment has to be made as to the percentage of vessels that are actually in use on a given day.

The assumptions provided in the following table have been used to estimate the likely usage of vessels on peak boating days by residents.

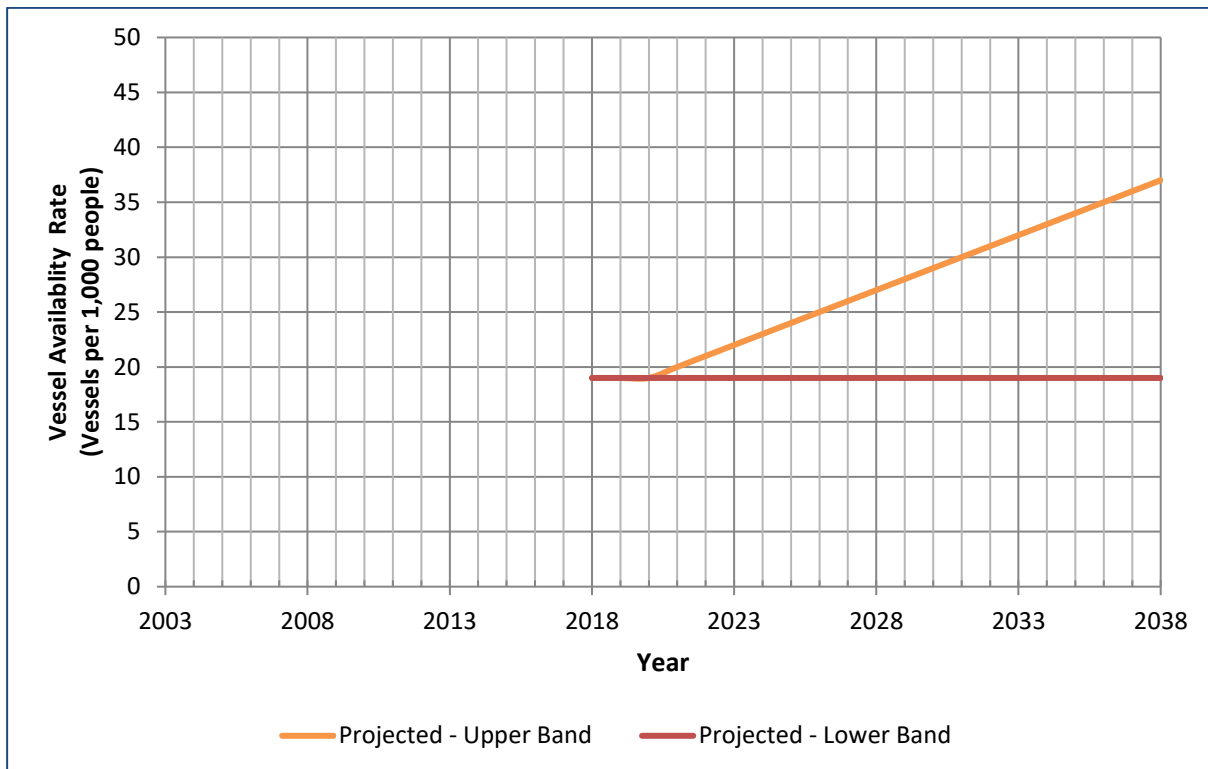
**Table 5.3 Vessel Usage Assumptions – Residents**

Item	Assessment
Resident vessels that regularly use the Facility	85%
Vessels that use the Facility more often than once a week	50%
Vessels used on the peak day of that week (most likely Saturday or Sunday)	28%
<b>Peak day vessel usage</b>	<b>12%</b>

Therefore, based on the estimated resident usage above, approximately 12% of the 691 registered vessels (82) can be attributed to residents that use the vessel on a peak day during peak season. There is no data available that can be used to estimate a proportion of visitors that bring a vessel to Exmouth and utilise the Facility. Based on the estimates presented previously in Section 4.5, this represents approximately 65% of the vessels that use the ramp on a peak day. On this basis, the remaining approximately 35% (43) of the vessels that use the ramp on a peak day during the peak season can be attributed to visitors.

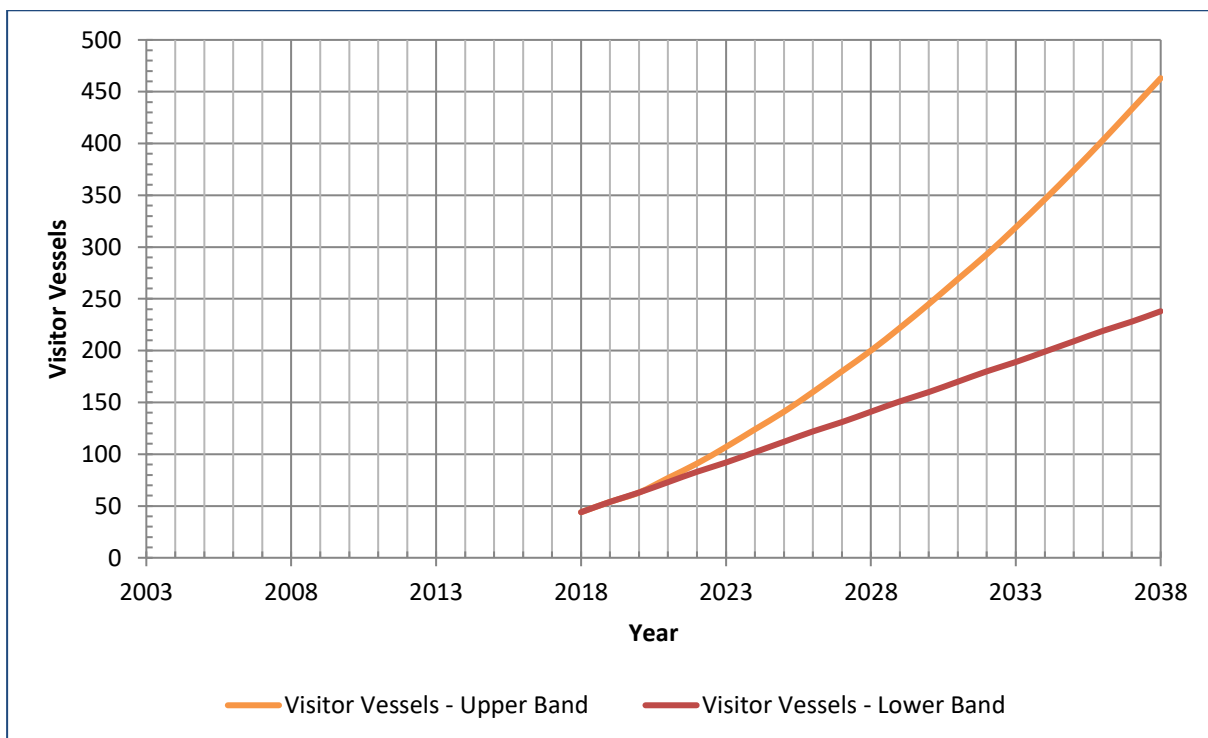
Therefore, approximately 19 vessels per 1,000 of the visitor population (43 out of 2,312) (discussed previously in Section 5.1.1) use the Facility on a peak day during the peak season. This percentage has been used to estimate the projected use of the Facility by visitors for the Lower Band using the 4-year Growth Rate projected tourist population.

The construction of an improved Facility is likely to attract more visitors to the Exmouth Region that intend to use their vessels at the Facility. On the assumption that a potential upgrade to the Facility would be completed by 2020, an increase of 1 additional vessel per 1,000 of the visitor population per year has been assumed from 2020 onwards for the Upper Band. Therefore, 37 vessels per 1,000 of the visitor population has been used by 2038. The Exmouth visitor vessel availability rate projections can be seen on the following figure.

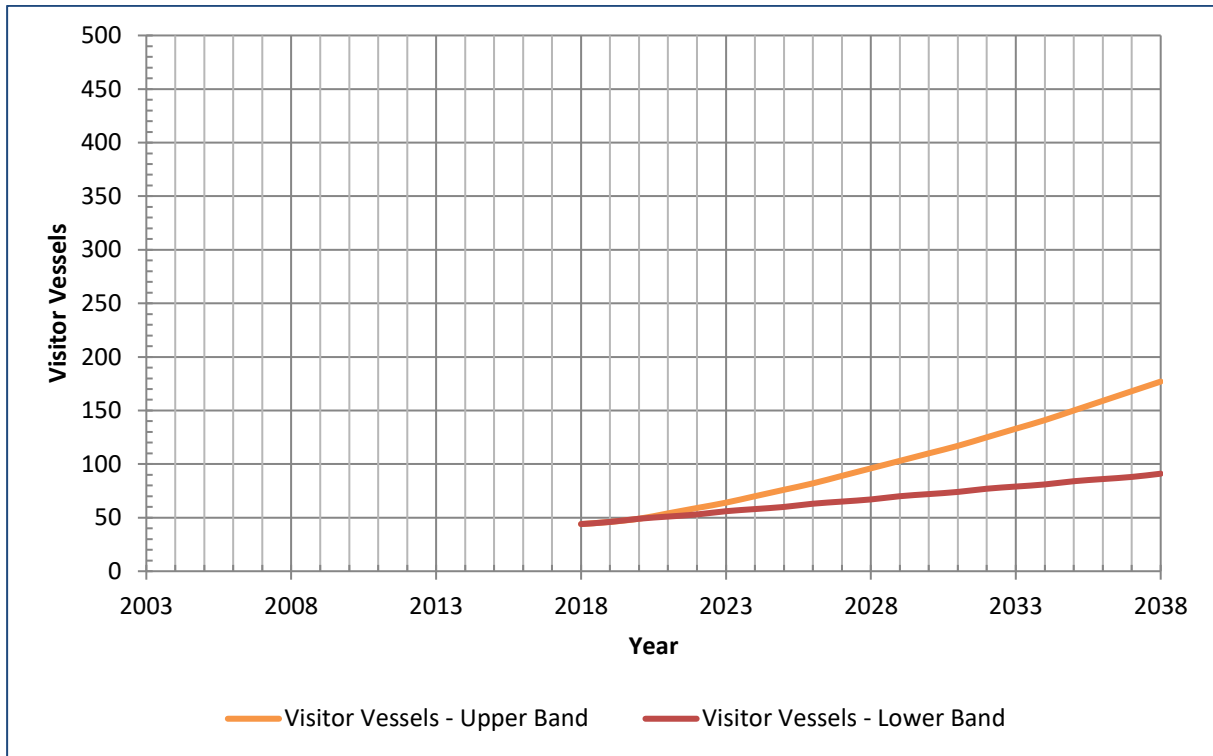


**Figure 5.7 Exmouth Visitor Projected Vessel Availability Rate**

An assessment of the total number of available vessels on a peak day of the peak season for the planning timeframe has been completed. Projections using the '4-year Growth' and '2-year Growth' rates are presented in Figure 5.8 and 5.9 respectively.



**Figure 5.8 Exmouth Visitor Projected Peak Day Vessels – '4-year Growth'**



**Figure 5.9 Exmouth Visitor Projected Peak Day Vessels – ‘2-year Growth’**

In reality, there is the potential for significant variability in the estimated future infrastructure requirements. An assessment as to the number of boat ramp lanes required to service the recreational and commercial trailered vessels has been estimated using the parameters presented. The results presented in the following tables have used the following combinations of projected rates:

- Table 5.4 – Residents (Aspirational) & Visitors (4-year Growth Rate).
- Table 5.5 – Residents (High) & Visitors (2-year Growth Rate).

The estimated infrastructure requirements can accommodate the total number of vessels on a peak day usage of vessels during the peak season at an assumed ramp capacity of 50 vessels per day.

**Table 5.4 Vessel Usage & Ramp Requirements – Aspirational & 4-year Growth**

Year	Upper Band				Lower Band			
	Resident Vessels in Use	Visitor Vessels in Use	Total	Ramp Lanes Required	Resident Vessels in Use	Visitor Vessels in Use	Total	Ramp Lanes Required
2018	88	43	131	3	88	43	131	3
2023	128	107	235	5	120	92	212	5
2028	184	200	384	8	162	141	303	7
2033	264	319	583	12	220	189	409	9
2038	365	463	828	17	299	238	537	11

Note: 1. This is based on an assumed single ramp lane capacity of 50 vessels per day.

**Table 5.5 Vessel Usage & Ramp Requirements – High & 2-year Growth**

Year	Upper Band				Lower Band			
	Resident Vessels in Use	Visitor Vessels in Use	Total	Ramp Lanes Required	Resident Vessels in Use	Visitor Vessels in Use	Total	Ramp Lanes Required
2018	88	44	132	3	88	44	132	3
2023	99	64	163	4	92	56	148	3
2028	113	96	209	5	100	67	167	4
2033	130	133	263	6	109	79	188	4
2038	144	177	325	7	118	91	209	5

Note: 1. This is based on an assumed single ramp lane capacity of 50 vessels per day.

Based on the assessment above, between 5 and 17 ramp lanes are required by the end of the planning timeframe for the various scenarios outlined above. For the proposed upgrades to the Facility outlined in Section 6 it has been assumed that 8 lanes and the associated finger jetties will be required.

Given the need for separation of commercial and recreational activity, 2 commercial loading jetties are recommended by the end of the planning timeframe. The preferred solution presented in the following section utilises existing infrastructure to meet these total recommended infrastructure numbers.

## 6. Concept Options

Given the current issues faced at the existing site, both improvements to the existing Facility and investigation of alternative sites have been considered and are discussed in the following Sections.

### 6.1 Existing Site

In regard to the existing site, the following two options have been assessed as a part of the scope of this investigation:

- Short Term Option – Improved management of the existing facility.
- Recommended Solution – Expansion & Realignment.

There are also numerous 'Mid-way Options' that exist between those mentioned above. These options can be tailored to match potential funding opportunities, timings of construction stages and improvement of some of the current priority issues with the existing Facility.

The two investigated options at the existing site and potential "Mid-way Options" that can be further investigated are discussed in the following sections.

#### 6.1.1 Short Term Option – Improved Management of the Existing Facility

Management issues of the existing facility that can be improved include the following:

- Facility usage rules.
- Commercial operator usage management.
- Sediment siltation management.

Currently there is no guidance on the usage rules of the Facility. Development of Facility rules is recommended. These rules could be outlined on signage at the Facility and could include vessels/vehicles that have right of way, car-park speed restrictions and no standing areas. These rules will give guidance to users to avoid conflicts that may arise otherwise and can be enforced by the Shire's Rangers during spot checks of the Facility.

Given licences for commercial operators currently exist, licence conditions could be implemented to alleviate pressures during peak usage times. An example of a management condition would be assigned launching and retrieval time for the individual commercial operators to reduce peakiness of usage. The information provided by the commercial operators in the online survey could be used to guide the designated time slots for each commercial operator.

For future sediment management operations, the following is recommended:

- An assessment of sediment movement be completed to identify optimal operational timing and sediment extraction volumes to minimise the siltation of the Facility.
- Disposal of extracted sediment on the beach north of the Facility.
  - This will help alleviate potential erosion hazards of the existing water tank and ablution block that may arise in the near future. The potential erosion hazard timeframes can be investigated as a part of the sediment movement assessment.

- This will also reduce the use of overflow parking for sediment disposal areas and reduce congestion during peak usage times.
- Clear documentation of the ongoing maintenance sediment extraction operations from the beach south of the Facility. The documentation should include timing, quantity and extents of sediment extraction and disposal areas.
- Better records of sediment extraction volumes to assist in the future management of sediment. Depending on the construction methodology and equipment used, quantify the volume of sediment removed. This can be completed by means of excavator bucket counts, the number truckloads of sediment and analysis of survey of extraction and disposal areas prior to and following the operations.

These management practices do not allow for the projected increase in usage of the Facility over the planning horizon and are only recommended as a short-term solution while one of the following expansion options or alternative sites are processed through the design and construction phases.

It is recommended that the Shire closes the Facility during cyclonic events to manage the associated risks including unsafe launching and retrieving conditions and unsafe vessel navigation.

#### **Ongoing Management Cost Estimate**

In order to reach their design lives, structures require ongoing and scheduled maintenance. Typically, maintenance of structures in the marine environment can cost approximately 5% of the capital cost of the structures every 10 years. This should be budgeted for over the course of the structures' design lives. The maintenance cost estimates provided in the following table are based on typical maintenance expenditure on similar structures.

The information for the sand management operation frequency and cost records for the existing Facility that was made available has been used to estimate likely future management costs. It is noted that seasonal and inter-annual fluctuations in sediment transport are likely to exist at the site and are required to be further investigated. Nevertheless, conceptual management cost estimates for the existing Facility over the next 10 years to 2028 are presented in the following table.

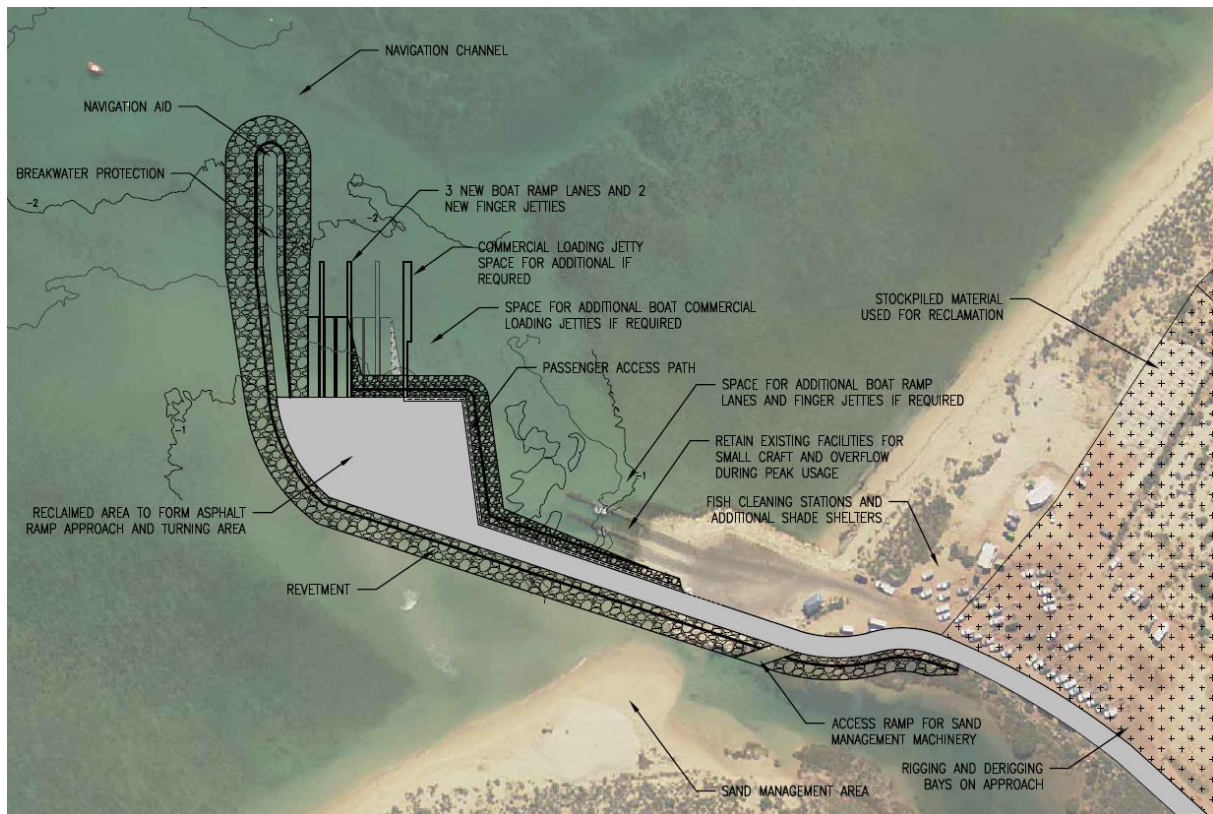
**Table 6.1 10 Year Maintenance & Monitoring Cost Estimate – Existing Facility**

Item	Description	Cost Per Operation (\$, excluding GST) <sup>1</sup>	Operational Frequency
<b>1</b>	<b><i>Sand Management<sup>1</sup></i></b>		
1.1	Sand extraction around boat ramps and from the beach south of the Facility	\$100,000	Annual
1.2	Dredging of the entrance channel	\$700,000	5 yearly
<b>2</b>	<b><i>Structure Maintenance<sup>1</sup></i></b>		
2.1	Structures including revetments, ramp lanes, finger jetties, access road, turning area, ablution block and channel markers	\$220,000	Decadal
<b>3</b>	<b><i>Ongoing Operations</i></b>		
3.1	Daily management operations including minor repairs, waste removal, enforcement of Facility rules and enforcement of users pays system	\$120,000	Annual
<b>4</b>	<b><i>Monitoring<sup>2</sup></i></b>		
4.1	Monitoring Surveys	\$25,000	Twice yearly for first 2 years, then review frequency
4.2	Monitoring Inspections, Analysis & Reporting	\$20,000	Yearly for the first 2 years, then review frequency
<b>Total<sup>3</sup> (\$, excluding GST)</b>		<b>\$4,050,000</b>	<b>N/A</b>

- Notes: 1. Allowances have been made for design, tender and construction phase services for sand management and maintenance operations. Maintenance estimates are on the basis that works are packaged together for completed by a lead Contractor.
2. Monitoring should be completed by experienced coastal engineering consultants.
3. Total maintenance cost based on 10-year planning timeframe to 2028 using operational frequency estimates and is in current day value. Assumes monitoring reduced to 5 yearly following first 2 years.

### 6.1.2 Recommended Solution – Expansion & Realignment

An extract of the Sketch of the proposed solution that improves all of the priority issues with the existing Facility (attached as Appendix E) is shown in the following figure.



**Figure 6.1 Recommended Solution – Expansion & Realignment**

The proposed Facility has been positioned and aligned to accommodate up to approximately 13 boat ramp lanes, 6 finger jetties and 3 commercial loading jetties without significant reconstruction works. This may accommodate the projected increase in Facility usage beyond the planning timeframe even if close to both ‘Aspirational’ residential population growth a visitor ‘4-year Growth’ are realised. It is noted that the cost estimates presented within this section only include the construction of 6 new boat ramps, 3 new finger jetties and 1 new commercial loading jetty to meet the recommended infrastructure.

As seen in Figure 6.1, an outer breakwater has been proposed and is aligned to improve the following existing issues:

- Exposure of the proposed Facility to swell waves.
- Exposure of the proposed Facility to strong dominant south south-westerly winds and associated wind generated waves. These currently act perpendicular to the beam of vessels when launching/retrieving at the existing Facility. This was identified as a safety hazard and should be improved.
- Reduced sedimentation of the ramps, provided adequate ongoing sand management of the southern beach is undertaken.

The extension of existing Facility alignment was chosen to not adversely affect environmental issues that blockage of Tantabiddi Creek may currently be causing. This would need to be further investigated and likely require monitoring prior to and following construction of the proposed Facility.

It is noted that under cyclonic events, sediment is likely to be transported from the northern beach in a southerly direction. This is likely to deposit sediment in front of the existing boat ramps and finger jetties that are proposed to be retained under this option. Further investigation of the sediment transport processes associated with the proposed Facility is recommended.

Dredging of the navigation channel and queuing area has been proposed. The dredge extents and target depth can be varied to suit the future vessel requirements. However, for the purposes of this investigation a target dredged elevation has been set at approximately -2.0 mAHD. The dredge spoil recovered is likely to be able to be reused as part of the reclamation fill volume required. The dredge spoil would be pumped/placed into the area held by the revetments proposed as the reclamation containment structures.

The turning area and access road are proposed to be asphalted.

The car and trailer parking area for the proposed Facility should be set out in accordance with the DoT guidelines and Australian Standards. The setout of the parking area is beyond the requirements of this investigation, which is focused on provision of the correct spatial allocation to enable the layout to be further developed in later stages of the design development.

Based on the standard requirements, an area of approximately 0.8 to 1.0ha would be required to cater for each boat ramp lane. This includes the following:

- 50 car and trailer parking bays.
- Rigging and derigging areas.
- Loading and unloading areas.
- Parking for commercial and associated passenger vehicles.

Therefore, at the end of the planning timeframe approximately 6.4 to 8.0ha would be required. It is proposed that only half of these bays are formalised in the first instance, with the proposed adjacent area to be cleared and gravelled for use as overflow parking as required. At later stages of the planning timeframe these parking areas could be formalised with bitumen to the overflow area.

## Approvals

The approvals required for capital construction of the proposed Facility are likely to include the following:

- Environmental Approvals – Environmental Protection Authority (EPA) and Department of Water Environmental Regulation (DWER).
- Planning, Development and Heritage Approvals – Department of Lands, Planning & Heritage (DLPH) and Western Australian Planning Commission (WAPC).
- Jetty Licences and Marine Safety Approvals – DoT.

## Capital & Ongoing Management Cost Estimates

The capital construction cost estimate of the proposed Facility is presented in the following table.

**Table 6.2 Concept Capital Construction Cost Estimate**

Item	Description	Cost (\$, excluding GST) <sup>1</sup>
1	Preliminaries	\$2,100,000
2	Demolition	\$100,000
3	Revetments	\$2,150,000
4	Breakwater	\$1,775,000
5	Dredging and Reclamation	\$620,000
6	Boat Ramps	\$2,250,000
7	Finger Jetties	\$1,670,000
8	Road, Ramp Approach and Turning Area	\$440,000
9	Car-park	\$2,900,000
10	Miscellaneous including Signage, Navigation Aids, Fish Cleaning Station, Shade Shelter and CCTV	\$250,000
11	<b>Subtotal (\$, excluding GST)</b>	<b>\$14,215,000</b>
12	Management & Design Fees	\$1,500,000
13	Contingencies	\$3,600,000
<b>Total (\$, excluding GST)</b>		<b>\$19,315,000</b>

Notes: 1. Allowances have been made for approvals, design, tender and construction phase services.

2. Where available, rates used in the cost estimate have been taken from recently tender works in the Exmouth Region. Where required, rates have been taken from recently tendered works in the Perth Metropolitan region and factored to account for the regional site in line with estimates from construction cost consultants Ralph Beattie Bosworth Pty Ltd (RBB) (2016).

In order to reach their design lives, structures on require ongoing and scheduled maintenance. Typically, maintenance of structures in the marine environment can cost approximately 5% of the capital cost of the structures every 10 years. This should be budgeted for over the course of the structures' design lives. The maintenance cost estimates provided in the following table are based on the estimated capital construction costs.

**Table 6.3 20 Year Maintenance & Monitoring Cost Estimate – Proposed Facility**

Item	Description	Cost Per Operation (\$, excluding GST) <sup>1</sup>	Operational Frequency
<b>1</b>	<b><i>Sand Management<sup>1</sup></i></b>		
1.1	Sand extraction around boat ramps and from the beach south of the Facility	\$150,000	Annual
1.2	Dredging of the entrance channel	\$250,000	Decadal
<b>2</b>	<b><i>Structure Maintenance<sup>1</sup></i></b>		
2.1	Structures including revetments, ramp lanes, finger jetties, access road, turning area, ablution block and channel markers.	\$1,070,000	Decadal
<b>3</b>	<b><i>Ongoing Operations</i></b>		
3.1	Daily management operations including minor repairs, waste removal, enforcement of Facility rules and enforcement of users pays system	\$240,000	Annual
<b>4</b>	<b><i>Monitoring<sup>2</sup></i></b>		
4.1	Monitoring Surveys	\$25,000	Twice yearly for first 2 years, then review frequency
4.2	Monitoring Inspections, Analysis & Reporting	\$20,000	Yearly for the first 2 years, then review frequency
<b>Total<sup>3</sup> (\$, excluding GST)</b>		<b>\$10,760,000</b>	<b>N/A</b>

Notes: 1. Allowances have been made for approvals, design, tender and construction phase services for sand management and maintenance operations. Maintenance estimates are on the basis that works are packaged together for completed by a lead Contractor.

2. Monitoring must be completed by experienced coastal engineering consultants.

3. Total maintenance cost based on 20-year planning timeframe to 2038 using operational frequency estimates and is in current day value. Assumes monitoring reduced to 5 yearly following first 2 years.

### Construction Staging

Given the potential variation in population increases of both residents and visitors and associated vessel usage, it is recommended that the infrastructure is constructed in a staged approach. The exact timing for the stages of construction would be guided by ongoing monitoring of the Facility and realised vessel usage trends. This staged approach would delay expenditure on infrastructure until it is required. Based on the investigations completed, initial guidance for the timing of infrastructure construction is presented in the following table.

**Table 6.4 Staged Infrastructure Timing**

Item	Estimated Completion Date	Infrastructure in Stage
Stage 1	2020	<ul style="list-style-type: none"> <li>• Outer Breakwater and Revetments.</li> <li>• Reclamation.</li> <li>• 3 new boat ramp lanes.</li> <li>• 2 new finger jetties.</li> <li>• 1 new commercial passenger jetty.</li> <li>• Access road, turning areas and passenger path.</li> <li>• Carpark clearing and formalisation of half the area.</li> <li>• Fish cleaning station and new shade shelters.</li> </ul>
Stage 2 <sup>1</sup>	2028 (or when required)	<ul style="list-style-type: none"> <li>• Additional 4 boat ramp lanes (or however many required).</li> <li>• Additional 1 finger jetty.</li> </ul>

Note: 1. Infrastructure required in Stage 2 would be guided by the ongoing monitoring of the usage of the proposed infrastructure constructed in Stage 1.

### 6.1.3 Potential ‘Mid-way Options’

There are options that improve some of the key issues with the existing Facility, but not others, and may cause additional issues at the existing site. Examples of ‘Mid-way Options’ include the following:

- Dredge the reef platform to the north of the existing boat ramp to allow room for additional ramp lanes and finger jetties and associated vessel navigation and waiting areas. There are the following issues with this option:
  - Existing sedimentation issues would continue.
  - Does not solve priority issue of poor alignment of existing ramps and exposure to waves.
- Keep the existing boat ramps and finger jetties in the current location and construct a smaller outer breakwater with some additional boat ramp lanes. There are the following issues that require further investigation:
  - Trailered vessel turning area constraints.
  - Vessel navigation constraints associated with surrounding reef platforms.
  - Potentially more frequent blockage of the Tantabiddi Creek with sediment from adjusted swell alignment and the associated potential environmental issues.
  - Sand depositing on the reef platform to the south of the natural existing channel and the associated potential environmental issues.

## 6.2 Alternative Site

Given the extent of the ongoing management issues that are experienced at the existing site, potential alternative sites have been identified. The location identified as potential alternative sites shown in the following figure.

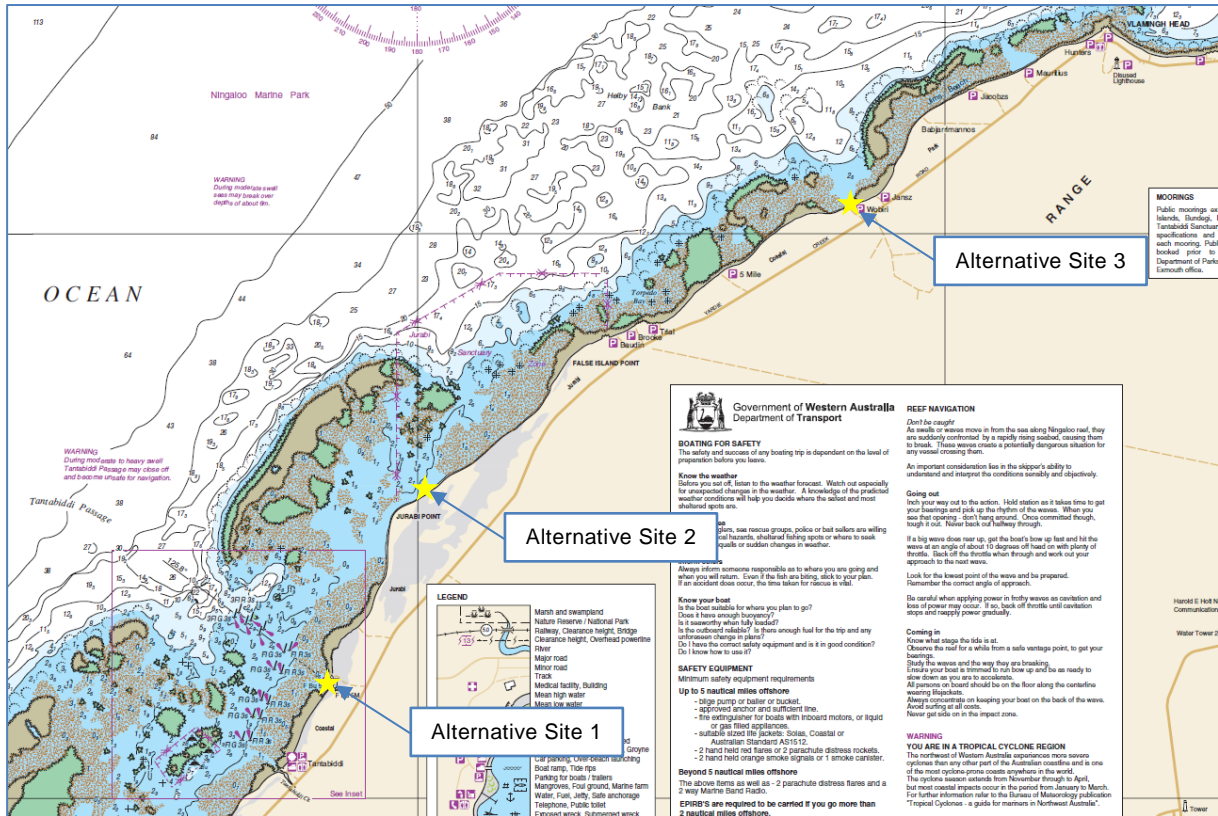


Figure 6.2 Potential Alternative Sites

The locations identified as potential alternative sites include the following:

- Alternative Site 1 – Tantabiddi channel navigation lead line.
- Alternative Site 2 – North of Jurabi Point.
- Alternative Site 3 – Wobiri car-park.

The potential for the identified alternative sites would need to be further investigated. These investigations would need to consider safety and functionality restraints, environmental and social impacts, capital and ongoing maintenance costs.

To gain a greater understanding of the functionality restraints of alternative sites, the following investigations are recommended:

- Sediment movement assessment.
- Topographic and hydrographic survey of the nearshore areas.
- Wave and water level data collection.

- Detailed wave and sediment modelling.

This would enable appropriate assessment of potential safety issues of the boat launching and navigation and allow for estimates of the protection requirements and ongoing management estimates for facilities at the potential alternative sites.

Following the functionality investigation, further community and stakeholder consultation is recommended for the potential alternative sites.

To consider the environmental impacts of the potential alternative sites, an environmental impact assessment is recommended.

## 7. Potential Funding Streams

### 7.1 Shire's Situation

Based on discussions with the Shire, in recent history, the Shire has been operating at a loss and the ongoing funding of the Facility is unsustainable. The forecasted average annual ongoing costs for the existing Facility and the proposed Facility are in the order of \$405,000 and \$538,000 per annum respectively. These costs are unable to be met by the Shire and it is likely that the existing Facility would fall into a state of disrepair. This could result in the eventual closure of the Tantabiddi Boat Launching Facility.

Based on discussion with the Shire, an increase in rates by 1% would only result in an increase in Shire revenue of approximately \$30,000 per year. Given the existing pressure on rates from rising governance costs, increases in rates to fund the ongoing costs of the Facility are not viable.

Likewise, given that approximately 50% of the current usage of the Facility can be attributed to the local commercial tourism industry that caters for local, national and international tourists, it is unreasonable for the Shire (and local rate payers that only attribute to a low percentage of the current usage of the Facility) to continue to fund the ongoing costs of the Facility. On this basis, it is recommended that the Shire seeks financial assistance from the State and Federal level for the ongoing costs of the existing Facility and the capital and ongoing costs of the proposed Facility.

### 7.2 Other Government Contributions

As mentioned previously, it is understood that the following government agencies and public service groups currently use the Facility for research and services in the area:

- DBCA.
- Department of Fisheries.
- Exmouth Volunteer Marine Rescue.

Currently, DBCA are the recipient of the licencing fees for commercial whale shark operators. However, no funding for maintenance of the Facility is provided by DBCA or the other above-mentioned users.

The DoT's business objectives aim to foster the improvement of boating facilities in Western Australia. However, there are currently no State Governments Statutory Requirements for DoT, or the Shire for that matter, to provide or manage recreational boat launching facilities. However, given the significant current usage of the Facility and projected significant usage demand for the proposed Facility, it is recommended that the Shire apply for State and Federal Government funding for the ongoing management cost of the existing Facility and the capital and ongoing management costs of the proposed Facility.

It is likely that the Shire would still be required to part fund the ongoing management of the existing or proposed Facility.

### 7.3 User-Pays

The potential for a user-pays system has been investigated. The user pays system can be a combination of payment from commercial, recreational and governmental agency user groups.

### **7.3.1 Commercial**

Given that licences for commercial use of the Facility currently exist, usage payment could be implemented as a licence condition. An example of commercial tourist operator funding stream for a local government owned and managed asset (City of Rockingham) that has recently been implemented is at the recently constructed Mersey Point Jetty (Jetty) in Rockingham, Western Australia. The Jetty is the gateway to Penguin Island from the mainland and is used by both recreational users and a commercial operator. This Jetty is therefore a reasonable comparison to the Tantabiddi Facility.

The Jetty was constructed as a replacement to a deteriorating old timber jetty. A funding agreement was reached between the commercial operator and the City of Rockingham and included a payment for each passenger that boarded the tour vessel via the Jetty.

Implementing a similar commercial funding system for each passenger boarding tour vessels via the Facility would be a fair and reasonable approach. This could be paid to the Shire at the end of each financial year or on a month by month basis. The finer details of the amount per passenger would need to be further investigation and agreed with all the commercial operators.

### **7.3.2 Recreational**

There are numerous other boat launching facilities in Western Australia that use parking tickets as a source of funding from recreational users. Given the issues with power supply at the site and the potential for vandalism to parking ticket machines, pre-purchased user passes could be a more cost-effective option. These passes could be available online, at the Shire's offices and/or at caravan sites, fishing shops and other local businesses in the Exmouth Region. The user passes could be via vehicle or vessel registration and would need to be displayed on the vehicles that have utilised the Facility to launch vessels. The user passes could be enforced by the Shire's Rangers during spot checks of the Facility and fines issues for noncompliance.

There is the potential for discounts to apply for rate paying residents of the Exmouth Region as it is likely some costs of the Facility would already be borne by the residents.

### **7.3.3 Government Agencies**

Similar to other user groups, government agencies that utilise the Facility for research or work-related purposes could be enforced to assist in funding of the management of the Facility.

### **7.3.4 Likely Costs Per Occurrence**

The estimate Facility usage for each user group in 2017 is presented in the following table. The numbers has been estimated to present as an example for the allocation of user pays as a cost per occurrence presented in the following table.

**Table 7.1 Estimated Users in 2017**

User	Number of Vehicles	Number of Vessels Launched	Number of Passengers
Recreational	N/A <sup>1</sup>	15,500	31,000
Commercial	62,500 <sup>2</sup>	2,500	27,000
<b>Total</b>	<b>62,500</b>	<b>17,000</b>	<b>58,000</b>

Note: 1. Number of vehicles is equal to the number of vessels launched for recreational users. To avoid double counting this has not been included.

2. Estimate accounts for vehicles towing commercial tender vessels to avoid double counting.

3. Estimates for government agencies are included in the recreation users estimates.

Based on the user pays system funding the average ongoing management and maintenance costs of the existing Facility discussed in Section 6, an example of costs per occurrences for each of the user groups are outlined in the following table.

**Table 7.2 User-Pays Estimates for Existing Facility (Based on Current User Distribution and Usage)**

User	Proposed Cost per Occurrence	Total Revenue Recouped
Vehicle	\$5	\$312,500
Vessels Launched	\$5	\$85,000
Passengers	\$1	\$58,000
<b>Total Revenue Recouped for Ongoing Management</b>		<b>\$455,500</b>
Average Annual Ongoing Costs Presented in Table 6.1		- \$405,000
<b>Impact on Shire Revenue</b>		<b>+ \$50,500</b>

It is noted that projected usage estimates of the proposed Facility changes on an annual basis over the planning timeframe for commercial and recreation vehicles, vessels and passengers. A rough initial estimate of the total revenue recouped using the costs per occurrences listed above may be in the order of \$15,000,000 to \$25,000,000 over the planning timeframe if a reasonable usage uptake of the proposed Facility is realised. This equates to approximately \$750,000 to \$1,250,000 average annual revenue recouped.

In regard to the proposed Facility, the average annual ongoing costs for the proposed Facility are approximately \$538,000 which is slightly higher than the ongoing costs for the existing Facility. The revenue recouped is likely to cover the ongoing costs of the proposed Facility. The cost differential may allow the Shire to fund the capital construction of the proposed Stage 2 infrastructure that may be required.

On the basis of the above, the example costs per occurrence required to be recouped to cover ongoing costs of the proposed Facility would be reasonably comparable and may be able to be reduced over time.

## 8. Conclusions & Recommendations

The investigation of the Tantabiddi Boat Launching Facility has shown that the existing Facility is heavily used by commercial and recreational users between March and October. The Facility is currently over capacity during these periods and extremely over capacity if the southern lane is silted over and unable to be used by deep draft vessels.

Improvements to the current management of the existing Facility have been recommended as well as a proposed Facility that would improve the current issues at the site and cater for the projected usages to 2038.

A summary of the recommendations arising from this investigation is provided below:

- A wave, water level and current measurement program is implemented by the Shire. This is likely to require measurements at nearshore and offshore locations and detailed wave modelling. This can be used to guide safety management of the existing Facility and further develop the proposed Facility at the existing site.
- A detailed sediment transport assessment is completed to confirm initial indicative predictions and estimate quantities of sediment movements. This would require detailed assessment of historical aerial images and collection and assessment of topographic and hydrographic surveys. The outcomes of this assessment can be used to improve management of the existing Facility and provide more detailed assessment of management of the proposed Facility.
- Implement changes to current management practices at the existing Facility in the short term while developing the recommended solution or potential alternative sites for a future facility.
  - Development and display of rules of the existing Facility.
  - Improved sand management records and practices.
  - Closure the Facility during cyclonic events to manage the associated risks including unsafe launching and retrieving conditions and unsafe vessel navigation.
- Community and stakeholder consultation of the proposed Facility.
- Investigations of potential alternative sites:
  - Shoreline movement assessments, wave and sediment modelling.
  - Topographic and hydrographic survey of the nearshore areas.
  - Wave and water level data collection.
  - Environmental impact assessments.
  - Community and stakeholder consultation.
- Shire to investigate alternative funding opportunities including state and federal support.

## 9. References

- Australian Bureau of Statistics, 2016, *Regional Estimated Population*. [ONLINE] Available at: [http://stat.data.abs.gov.au/Index.aspx?DatasetCode=ABS\\_ANNUAL\\_ERP\\_ASGS](http://stat.data.abs.gov.au/Index.aspx?DatasetCode=ABS_ANNUAL_ERP_ASGS) [Accessed 16 May 2018].
- Australian Bureau of Statistics, 2012, *Population Projections by Regions*. [ONLINE] Available at: <http://stat.data.abs.gov.au/Index.aspx?Queryid=306#> [Accessed 16 May 2018].
- Australian Bureau of Statistics, 2016, *Regional Estimated Population*. [ONLINE] Available at: <http://www.abs.gov.au/AUSSTATS/abs@.nsf/DetailsPage/3218.02014-15?OpenDocument> [Accessed 16 May 2018].
- Australian Bureau of Statistics, 2016, *Regional Estimated Population*. [ONLINE] Available at: [http://stat.data.abs.gov.au/Index.aspx?DatasetCode=ABS\\_ANNUAL\\_ERP\\_ASGS#](http://stat.data.abs.gov.au/Index.aspx?DatasetCode=ABS_ANNUAL_ERP_ASGS#) [Accessed 16 May 2018].
- Australian Bureau of Statistics, 2018. *Local Government Regions*. [ONLINE] Available at: <http://stat.abs.gov.au/itt/r.jsp?databyregion#/> [Accessed 22 May 2018].
- Bureau of Meteorology (BOM), 2016. *Wind Speed and Direction Rose*. [ONLINE] Available at: [http://www.bom.gov.au/cgi-bin/climate/cgi\\_bin\\_scripts/windrose\\_selector.cgi?period=MaytoSep&type=9&location=05007&Submit=Get+Rose](http://www.bom.gov.au/cgi-bin/climate/cgi_bin_scripts/windrose_selector.cgi?period=MaytoSep&type=9&location=05007&Submit=Get+Rose) [Accessed 25 May 2018].
- Department of Fisheries (DoF), 2015. *Seasonal wind patterns around the Western Australian coastline and their application in fisheries analysis*. Fisheries Research Report No. 266, 2015.
- Department of Mines & Petroleum (1978). *Onslow, SF49-5, First Edition*. Geological Survey of Western Australia.
- Department of Mines, Industry Regulation and Safety (DMIRS), 2017. [ONLINE] Available at: <https://geoview.dmp.wa.gov.au/GeoViews/?Viewer=GeoVIEW> [Accessed 25 May 2018].
- Department for Planning & Infrastructure (DPI), 2008. *Perth Recreational Boating Facilities Study*. Technical Report 444, Government of Western Australia.
- Department of Transport (DoT), 2010, *Broome Boating Facility*. Technical Report 483 Government of Western Australia
- Department of Transport (DoT), 2011, *Peel Region – Recreational Boating Facilities Study 2010*. Technical Report 449 Government of Western Australia
- Department of Transport (DoT), 2012, *Broome Boating Facility – Demand Study*. Technical Report 491. Government of Western Australia
- Department of Transport (DoT), 2016, *Town of Port Hedland Boat Registration Data*. Unpublished Statistics.
- Hornback, K.E. and Eagles, P.F.J., 1999. *Guidelines for Public Use Measurement and Reporting at Parks and Protected Areas*. World Commission on Protected Areas (WCPA), IUCN, Gland, Switzerland and Cambridge, UK.

MetroCount, 2009. MTE User Manual 3.21 – Classification Schemes.

MRA 2013, *Port Geographe Boat Trailer Parking – Planning Study*, 13035 Rev 1. Prepared for the City of Busselton.

MRA, 2014. *Extreme Water Level Analysis – Summary & Results*, R497 Rev 0. Prepared for M P Rogers & Associates Pty Ltd.

MRA, 2016. *Recreational Boating Facility Demand Study – Port Hedland*, Report R491 Rev 2. Prepared for LandCorp.

RBB, 2016. *Compendium 2016 – Perth*.

Shire of Exmouth (Shire), 2012. *WA Tomorrow Population - SoEX Local Planning Strategy 2015-2025*, Report No.7 2006 to 2026.

URS, 2015. *Sand Bypassing Tantabiddi – General Arrangement Plan & Section, Drawing BUmber 42908753-MA-003 Rev A*. Prepared for the Shire of Exmouth.

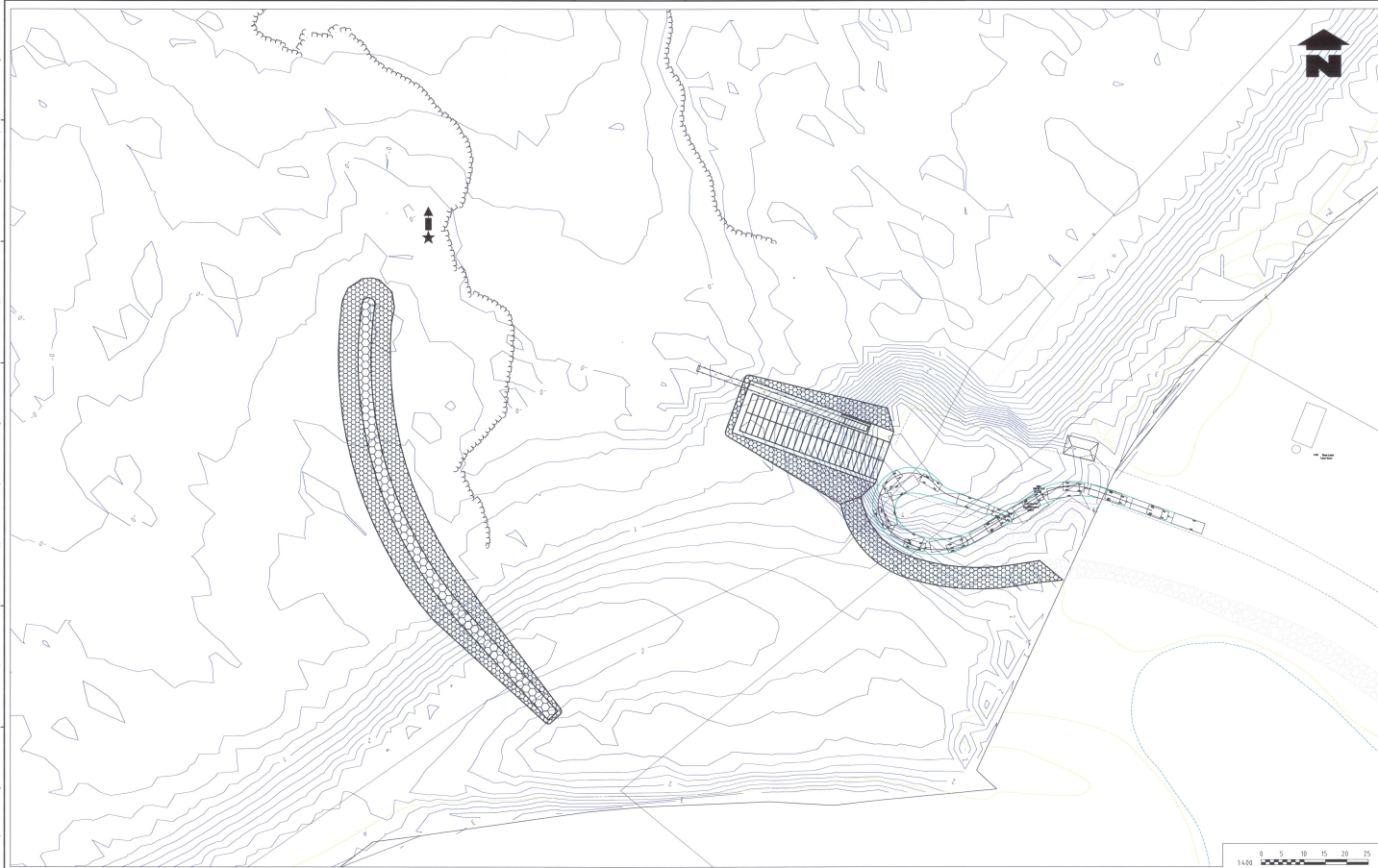
URS, 2016. *Sand Bypass Dredging & Revetment Repair - Close Out Report, 42908753/Rep02/1*.

## **10. Appendices**

- Appendix A      Facility Improvement Investigation Drawings (DPI 2004)**
- Appendix B      Existing Facility Drawings (URS 2012)**
- Appendix C      Existing Facility Dredging Design Drawings (URS 2015)**
- Appendix D      Tantabiddi Submergence Curve (DoT 2012)**
- Appendix E      Long Term Expansion & Realignment Solution Sketch**

**Appendix A Facility Improvement Investigation Drawings (DPI 2004)**





**GENERAL NOTES**

1. PEBARA\_COASTLIN\_AUG\_2004.ECW AERIAL PHOTOGRAPHY BASE
2. BATHYMETRY DERIVED FROM TND305HY/XS550

TIDE LEVELS						
DALT	MIDRIS	MIDRIN	JUL	MSLN	MSLS	LAT
2.64	1.84	1.31	1.08	0.87	0.54	8.38

**SCALE**

1:400 @ A1

UNLESS OTHERWISE SPECIFIED DIMENSIONS IN METRES

VERT: SOUNDING DATUM - WHICH IS 3.453m BELOW PAAD BY BVSZ AND 1.07m BELOW AHD

SEE MANAGER APPLICATION FOR SCALE-LAYER BOUNDARY

**DESIGNER**

L. CASSIDY

**APPROVED**

M. BAIRD

**DATE**

01/01/2011

**PROJECT**

BOAT LAUNCH FACILITIES

**OPTION 1B**

**MANAGER**

M. BAIRD

**DATE**

01/01/2011

Department for Planning and Infrastructure

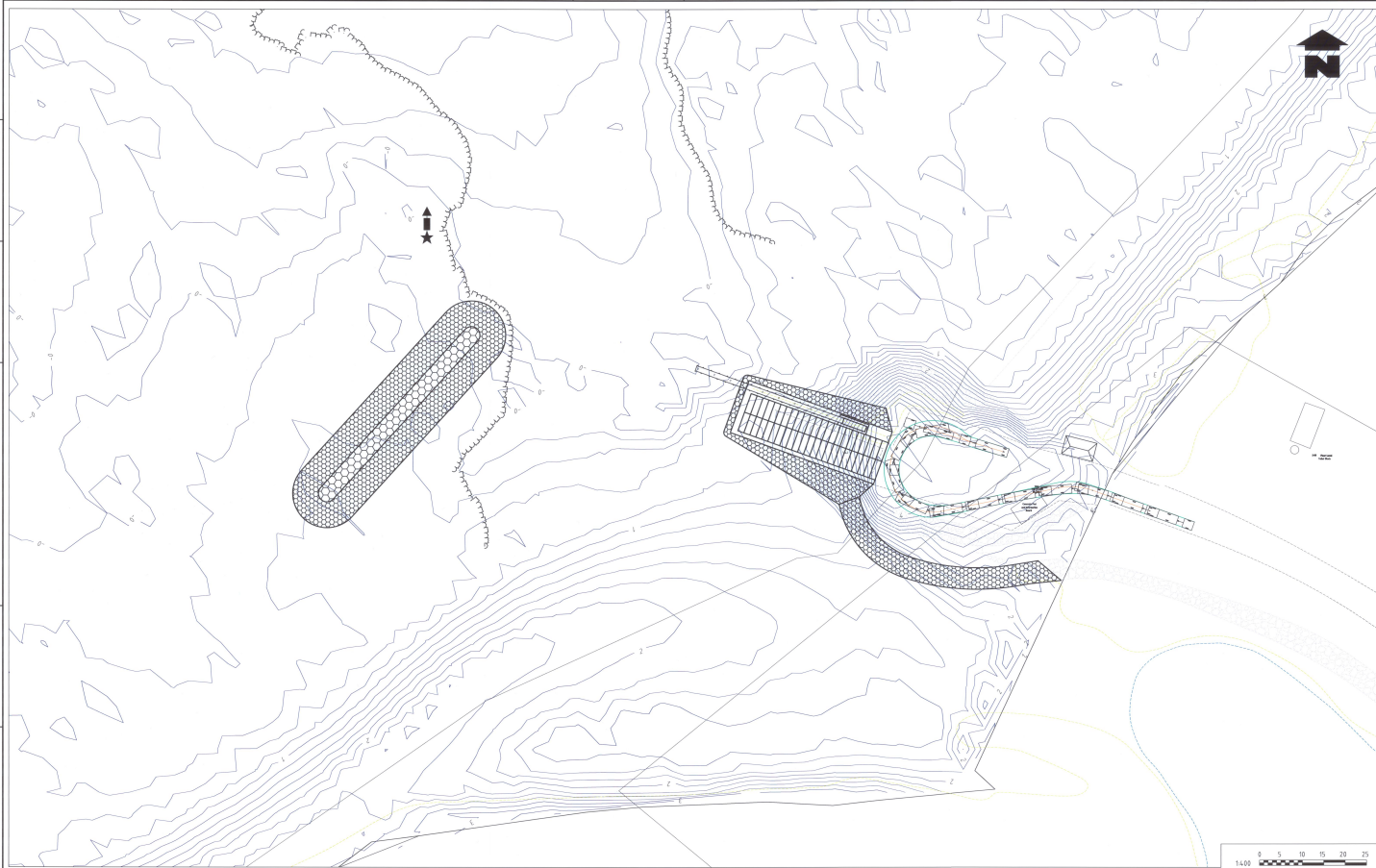
TANTABDIDI  
BOAT LAUNCH FACILITIES  
OPTION 1B

DRAWING NUMBER

0054 - 02 - 02



Sheet A



**GENERAL NOTES**  
 1. PILBARA\_COASTLN\_AUG\_2004 ECV AERIAL PHOTOGRAPHY BASE  
 2. BATHYMETRY DERIVED FROM 1N0395H7X555

TIDE LEVELS					
GAUL	MIDWHS	LOWWTR	HIGH	ALWTR	ALWHS [LAT]
2.04	1.84	1.31	1.84	2.87	0.54

SCALE 1:400 @ A1

UNLESS OTHERWISE STATED DIMENSIONS IN METERS  
 HORIZ: MAP GRID OF AUSTRALIA BASED ON GDA94 - ZONE 49  
 VERT: SOUNDING DATUM - WHICH IS 3.453m BELOW PWD BY RPSD AND 0.20m BELOW AHD

DESIGNED BY L. CASSIDY

PROJECT MANAGER M. BAIRD

APPROVED

MANAGER COASTAL SERVICES

REV	DATE	BY	CHKD	DESCRIPTION
A	29.09.20			ISSUED FOR COMMENT

Department for Planning and Infrastructure

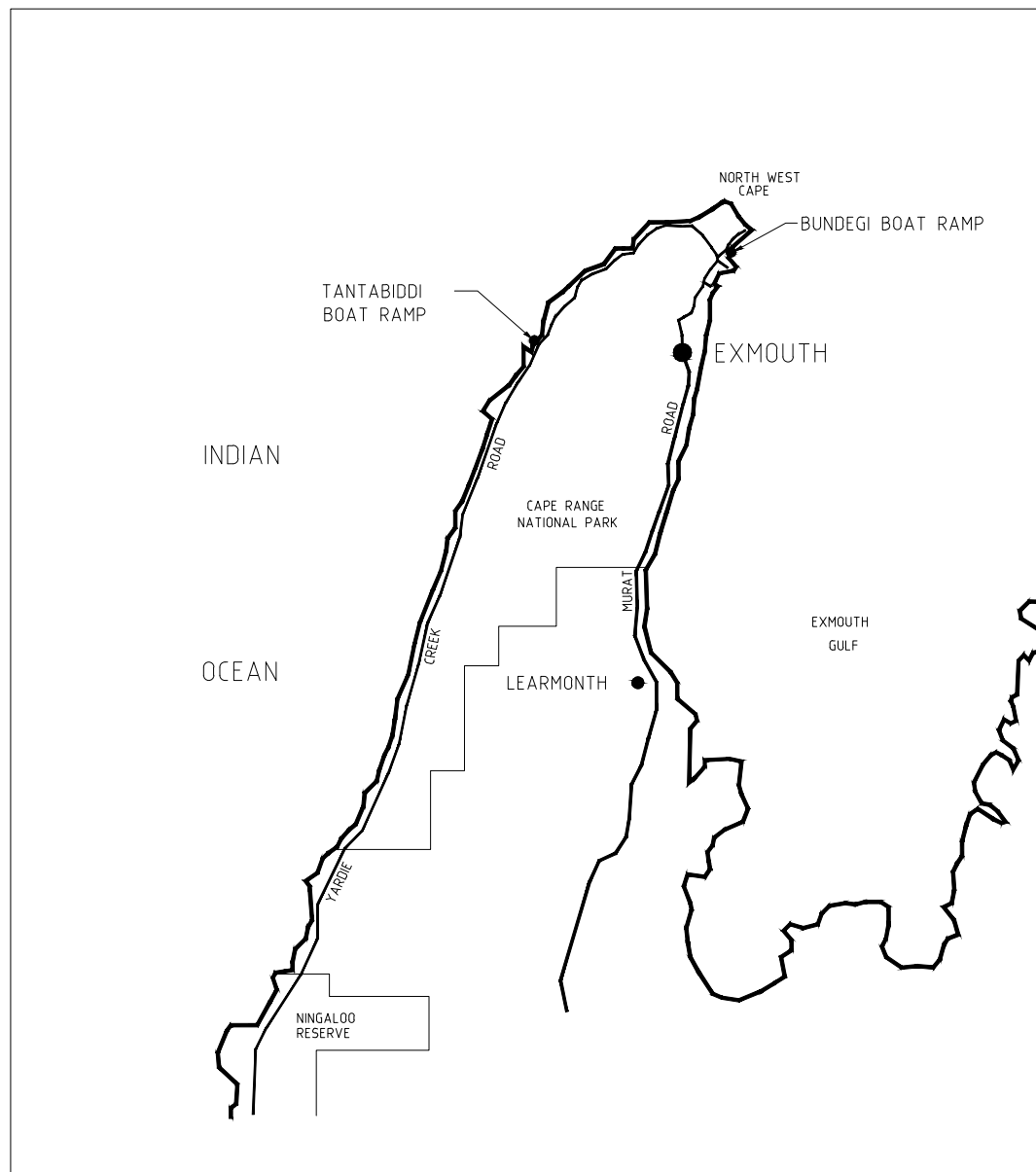
TANTABIDDI  
 BOAT LAUNCHING FACILITIES  
 OPTION 1C

0054 - 02 - 03

1:CAD\170054-02-03\_A.dwg

**Appendix B Existing Facility Drawings (URS 2012)**

# EXMOUTH TANTABIDDI BOAT RAMP CIVIL AND STRUCTURAL CONSTRUCTION DRAWINGS SHIRE OF EXMOUTH



## DRAWING INDEX

DRAWING NUMBER	TITLE
1399 - 01 - 01	LOCALITY PLAN AND DRAWING INDEX.
1399 - 02 - 01	GENERAL NOTES.
1399 - 03 - 01	GENERAL ARRANGEMENT & SITE LAYOUT.
1399 - 04 - 01	TURNAROUND.
1399 - 05 - 01	LONGITUDINAL & TYPICAL SECTIONS.
1399 - 06 - 01	PEDESTRIAN RAMP - 1 OF 2.
1399 - 06 - 02	PEDESTRIAN RAMP - 2 OF 2.
1399 - 07 - 01	PRE-CAST SLAB DETAILS.
1399 - 08 - 01	ADDITIONAL JETTY - GENERAL ARRANGEMENT.
1399 - 08 - 02	ADDITIONAL JETTY - LONGITUDINAL & TYPICAL SECTIONS.
1399 - 08 - 03	ADDITIONAL JETTY - STEELWORK CONNECTION DETAILS, SHEET 1 OF 2.
1399 - 08 - 04	ADDITIONAL JETTY - STEELWORK CONNECTION DETAILS, SHEET 2 OF 2.
1399 - 08 - 05	ADDITIONAL JETTY - MISCELLANEOUS DETAILS.

REV#	ZONE	DATE	AMENDMENT	DRN	DESIGN APPROVAL
E		14.04.11	ISSUED FOR TENDER	S0'B	SM
D		13.01.11	ISSUED FOR TENDER	AS	NS
C		15.12.10	RE ISSUED FOR REVIEW	S0'B	SM
B		19.11.10	RE ISSUED FOR REVIEW	AS	SM
A		JUNE 07	ISSUED FOR REVIEW	MC	SM

GENERAL NOTES						
1. 2005 - R12C5.ECW AERIAL PHOTOGRAPHY BASE						
2. BATHYMETRY DERIVED FROM tn_hy_z49.dwg						
3. LAND CONTOURS DERIVED FROM 4983.dwg						

TIDE LEVELS						
HAT	MHWS	MHWN	MSL	MLWN	MLWS	LAT
2.87	2.35	1.76	1.44	1.16	0.55	0.03

**URS**

LEVEL 3  
20 TERRACE ROAD  
EAST PERTH WA 6004 AUSTRALIA  
TEL: 61 8 9326 0100  
FAX: 61 8 9326 0296

SCALE:	<b>NTS</b>	
HORIZ: EXM 94	UNLESS OTHERWISE STATED DIMENSIONS IN	m
VERT: AHD		
DESIGNED	S.M	APPROVED
CHECKED	N.S	APPROVED
DRAWN	M.C	APPROVED
CHECKED	S.M	APPROVED
PROJECT MANAGER	N.S	AUTHORISED

**Department of Transport**

EXMOUTH  
TANTABIDDI BOAT RAMP  
LOCALITY PLAN AND DRAWING INDEX

DRAWING NUMBER **1399 - 01 - 01**

REV# **E**



# GENERAL NOTES

## NOTES FOR TANTIBIDDI BOAT RAMP DRAWINGS

### GENERAL

- ALL DRAWINGS ARE TO BE READ IN CONJUNCTION WITH ALL OTHER RELEVANT DRAWINGS AND SPECIFICATIONS AND WITH SUCH WRITTEN INSTRUCTIONS AS MAY BE ISSUED DURING THE COURSE OF THE CONTRACT.
- ALL DISCREPANCIES SHALL BE REFERRED TO THE SUPERINTENDENT BEFORE PROCEEDING WITH THE WORK.
- ALL DIMENSIONS RELEVANT TO THE SETTING OUT AND OFF SITE WORK SHALL BE VERIFIED BY THE CONTRACTOR BEFORE CONSTRUCTION AND FABRICATION IS COMMENCED. THESE DRAWINGS SHALL NOT BE SCALED.
- DURING CONSTRUCTION THE CONTRACTOR SHALL BE RESPONSIBLE FOR MAINTAINING THE STRUCTURE IN A SAFE AND STABLE CONDITION AND SHALL ENSURE THAT NO PART IS OVER STRESSED DURING CONSTRUCTION ACTIVITIES.
- ALL WORKMANSHIP AND MATERIALS SHALL BE IN ACCORDANCE WITH THE RELEVANT S.A.A. CODES OR EQUIVALENT INCLUDING AMENDMENTS AND THE LOCAL STATUTORY AUTHORITIES EXCEPT WHERE VARIED BY THE CONTRACT DOCUMENTS.
- NO SUBSTITUTIONS SHALL BE MADE OR SIZES OF STRUCTURAL MEMBERS VARIED WITHOUT OBTAINING THE APPROVAL OF THE SUPERINTENDENT. THE APPROVAL OF A SUBSTITUTION MUST BE IN WRITING FROM THE SUPERINTENDENT AND SHALL NOT BE AN AUTHORISATION FOR AN EXTRA. ANY EXTRA INVOLVED SHALL BE TAKEN UP WITH THE SUPERINTENDENT AND AUTHORISED IN WRITING BEFORE WORK COMMENCES.
- ALL DIMENSIONS ARE IN MILLIMETRES UNLESS STATED OTHERWISE.
- ANY VARIATION TO THE DETAILS SHOWN ON THE DRAWINGS MUST BE AUTHORISED BY THE SUPERINTENDENT PRIOR TO FABRICATION AND CONSTRUCTION.
- PRIOR TO THE PLACEMENT OF ANY FILL OR PAVEMENT, THE EXPOSED SUB-GRADE SHALL BE COMPACTED IN ACCORDANCE WITH AS 1289. TO THE APPROVAL OF THE SUPERINTENDENT. ANY SOFT SPOTS SHALL BE REMOVED AND REPLACED WITH APPROVED FILL AND COMPACTED.
- THE CONTRACTOR SHALL BE RESPONSIBLE FOR THE DEWATERING OF ALL TRENCHES
- THE CONTRACTOR SHALL DISPOSE OF EXCESS SPOIL AS DIRECTED BY THE SUPERINTENDENT
- ALL ASSETS MODIFIED OR DAMAGED BY THE PROPOSED WORKS SHALL BE REINSTATED TO THE SATISFACTION OF SHIRE OF EXMOUTH
- PRIOR TO COMMENCING WORK, THE CONTRACTOR SHALL PREPARE AND FORWARD TO COUNCIL'S ENGINEER, A REPORT ON THE CONDITION OF ANY EXISTING COUNCIL CONTROLLED INFRASTRUCTURE IN THE VICINITY OF THE WORK SITE. THE REPORT SHALL LIST THE LOCATION AND EXTENT OF ANY EXISTING DAMAGE TO INFRASTRUCTURE SUCH AS ROAD PAVEMENT, KERB AND CHANNEL, DRAINS, DRAINAGE PITS, FOOTPATHS, ROAD SIGNS ETC. THE CONTRACTOR WILL BE HELD RESPONSIBLE FOR ALL DAMAGED ASSETS THAT ARE NOT REPORTED PRIOR TO COMMENCEMENT TO WORK.

### REINFORCEMENT

- THE CONTRACTOR SHALL SUPPLY ALL NECESSARY BAR CHAIRS, SUPPORT AND SPACER BARS TO ENSURE REINFORCING STEEL IS PLACED IN ITS CORRECT POSITION DURING CONSTRUCTION.
- REINFORCEMENT IS SHOWN DIAGRAMMATICALLY AND NOT NECESSARILY IN TRUE PROJECTION. SET REINFORCEMENT OUT AT EQUAL CENTRES WHERE SPACING IS NOT SPECIFIED.

### CONCRETE WORK

- ALL CONCRETE AND REINFORCEMENT SHALL BE IN ACCORDANCE WITH THE CURRENT EDITION OF AS 3600.
- ALL CONCRETE SUPPLIED SHALL HAVE MAXIMUM NOMINAL AGGREGATE SIZE OF 20mm AND A SLUMP OF 80mm IMMEDIATELY PRIOR TO PLACING CONCRETE. VARIATIONS FOR THESE SHALL BE APPROVED BY SUPERINTENDANT.
- CLEAR COVER TO ALL REINFORCEMENT AND CONCRETE GRADE SHALL BE AS FOLLOWS UNLESS NOTED OTHERWISE :
 

ELEMENT	COVER (mm)	GRADE (MIN)
ABUTMENT AGAINST GROUND	70	S50
FORMED	65	
PRECAST SLABS		S50
- BLINDING CONCRETE COMPRESSIVE STRENGTH SHALL BE  $f'c = 15 \text{ MPa}$
- ALL CONCRETE SHALL BE SUBJECT TO PROJECT ASSESSMENT OF STRENGTH.
- ADDITIVES OTHER THAN SPECIFIED ARE NOT PERMITTED WITHOUT WRITTEN APPROVAL FROM THE SUPERINTENDENT.
- FREE DROPPING OF CONCRETE FROM A HEIGHT GREATER THAN 1200mm SHALL NOT BE PERMITTED.
- CONCRETE SHALL BE COMPACTED WITH SUITABLE VIBRATOR DURING PLACEMENT.
- ALL CONCRETE IN EACH SEPARATE POUR SHALL BE PLACED AND MECHANICALLY VIBRATED IN ONE CONTINUOUS OPERATION.
- PROVIDE AND BUILD-IN BOLTS, PIPES, ETC. AS REQUIRED BY THE SUPERINTENDANT. NO HOLES OR CHASES SHALL BE MADE IN ANY CONCRETE WITHOUT THE APPROVAL OF THE SUPERINTENDENT.
- CONSTRUCTION JOINTS OTHER THAN THOSE SHOWN ON DRAWINGS SHALL BE LOCATED TO THE SATISFACTION OF THE SUPERINTENDENT. THE CONTRACTOR SHALL ALLOW FOR ALL NECESSARY CONSTRUCTION JOINTS.
- CONCRETE SHALL HAVE A DURABILITY SUITABLE FOR A 25 YEAR DESIGN LIFE. THE CONTRACTOR IS TO SUPPLY A MIX DESIGN WITH SUITABLE ADDITIVES TO ALLOW FOR THIS DURABILITY GIVEN THAT THE CONCRETE IS IN THE SPLASH ZONE.

### PRECAST CONCRETE SLABS

- TEMPORARY LIFTING AND STORAGE OF THE PRECAST SLAB PANELS IS THE RESPONSIBILITY OF THE CONTRACTOR. THIS SHALL INCLUDE HANDLING PROCEDURE OF THE UNITS THROUGHOUT ALL STAGES INCLUDING STRIPPING, LIFTING, TRANSPORTATION AND ERECTION. CONCRETE STRESSES THROUGHOUT HANDLING SHALL NOT CAUSE CRACKING. CONTRACTOR SHALL HAVE DESIGN RESPONSIBILITY FOR ALL LIFTING PROCEDURES INCLUDING SIZING AND LOCATION OF ALL LIFTING INSERTS.
- THE CONTRACTOR SHALL SUPPLY AND FIT LIFTING FIXINGS AS REQUIRED. THESE SHALL TAKE THE FORM OF PROPRIETARY CAST-IN CABLES OR FERRULES. NO OTHER HOLES, RECESSES OR CHASES OTHER THAN THOSE SHOWN ON THE STRUCTURAL DRAWINGS SHALL BE ALLOWED WITHOUT PRIOR WRITTEN APPROVAL OF THE SUPERINTENDENT. ALL EMBEDDED LIFTING FIXINGS SHALL BE DESIGNED FOR A 25 YEAR LIFE SPAN IN A SPLASH ZONE.
- MESH REINFORCING SHALL BE ONE CONTINUOUS SHEET PER SLAB.

### FORMWORK

- FORMWORK SHALL NOT BE STRIPPED UNTIL THE CONCRETE STRENGTH IS SUFFICIENT TO SUPPORT THE LOADS WITHOUT EXCESSIVE DISTORTION OR CRACKING. NOT WITHSTANDING THIS REQUIREMENT, THE MINIMUM STRIPPING TIMES SHALL BE 7 DAYS.
- PROVIDE ALL EXPOSED EDGES AND CORNERS WITH 25MM CHAMFERS UNLESS NOMINATED OTHERWISE.
- THE CONTRACTOR SHALL BE RESPONSIBLE FOR THE STRUCTURAL SUFFICIENCY OF ALL FORMWORK.

### EARTHWORKS

TURNAROUND FILL SHALL BE LOCALLY SOURCED SAND FROM A LOCATION SPECIFIED BY THE SHIRE OF EXMOUTH. LIMESTONE CORE STONE SHALL BE UP TO 0.5t WITH FINES (-150mm), LESS THAN 20% BY VOLUME. GRANITE AGGREGATE SHALL 25mm TO 100mm

### DESIGN CRITERIA

- THE FOLLOWING MATERIAL PROPERTIES HAVE BEEN USED IN THE DESIGN:

-CONCRETE STRENGTH  $f'c = 50 \text{ MPa}$   
 -REINFORCING STEEL Y BARS  $f_{sy} = 500 \text{ MPa}$   
 R BARS  $f_{sy} = 250 \text{ MPa}$

### DESIGN LOADS

- STRUCTURE DESIGNED FOR TRAILERABLE VESSELS AS SHOWN IN AS 3692-2001, FIGURE 7.1.

### STEELWORK SURFACE TREATMENT

ACCORDING TO SPECIFICATION.

### STEELWORK

- ALL WORKMANSHIP AND MATERIALS SHALL BE IN ACCORDANCE WITH AS4100. STEEL SHALL BE ORDINARY WELDABLE GRADE TO AS3678 AND AS3679 UNLESS NOTED OTHERWISE.
- UNLESS NOTED OTHERWISE MATERIALS SHALL BE AS FOLLOWS :
 

ANGLE SECTIONS & PLATE	AS3678/3679	GRADE 250
UB, UC & PFC SECTIONS	BHP SPEC.	GRADE 300 PLUS
HOLLOW SECTIONS	AS1163	GRADE 350
- ALL SHOP DETAIL DRAWINGS REQUIRED FOR THE WORKS SHALL BE PREPARED BY THE CONTRACTOR. TWO COPIES OF SHOP DETAIL DRAWINGS SHALL BE SUBMITTED TO THE SUPERINTENDENT AND APPROVAL OF THE SAME OBTAINED BEFORE COMMENCING FABRICATION. APPROVAL WILL NOT COVER DIMENSIONS OR LAYOUT.
- ALL DAMAGED PAINTWORK, NUTS, BOLTS AND WASHERS SHALL BE MADE GOOD BY THE CONTRACTOR.
- WELDING SHALL BE IN ACCORDANCE WITH AS1554. WELDING SHALL BE CLASS SP E48XX UNLESS NOTED OTHERWISE.
- BOLTS ARE DESIGNATED ON THE DRAWINGS BY THE NUMBER, DIAMETER, GRADE AND TIGHTENING PROCEDURE IN ACCORDANCE WITH AISC BOLTING PROCEDURES (STANDARDISED STRUCTURAL CONNECTIONS).
- 8.8/TB DENOTES GRADE 8.8 BOLTS TO AS1252 TENSIONED BEARING. BOLTS FULLY TENSIONED SHALL NOT BE RETIGHTENED ONCE TIGHTENED, BUT SHALL BE DISCARDED. LOAD INDICATOR WASHERS OR TURN OF NUT METHOD SHALL BE ADOPTED. NO PAINT SHALL BE APPLIED TO MATING SURFACES WHICH SHALL BE CLEAN AND FREE OF SCALE. BOLTS FULLY TENSIONED IN ACCORDANCE TO AS1511.
- UNLESS NOTED OTHERWISE WELDS SHALL BE 6mm CONTINUOUS FILLET. MINIMUM OF 2M20 8.8/TB BOLTS PER CONNECTION U.N.O.
- THE ERECTION CONTRACTOR SHALL BE RESPONSIBLE FOR AND LEAVE IN PLACE UNTILL PERMANENT BRACING ELEMENTS ARE CONSTRUCTED, SUCH TEMPORARY BRACING AS IS NECESSARY TO STABILISE THE STRUCTURE DURING ERECTION.
- GALVANISED MEMBERS SHALL CONFORM TO AS1214 AND AS1650. PREPARATION AND PRE-TREATMENT OF SURFACES SHALL BE IN ACCORDANCE WITH AS1627. ANY DAMAGED GALVANISED SURFACE SHALL RECEIVE ONE SITE COAT OF APPROVED ZINC EPOXY PAINT.

REV#	ZONE	DATE	AMENDMENT	DRN	DESIGN APPROVAL
E		14.04.11	ISSUED FOR TENDER	SO'B	SM
D		13.01.11	ISSUED FOR TENDER	AS	NS
C		14.12.10	RE ISSUED FOR REVIEW	AS	SM
B		06.12.10	RE ISSUED FOR REVIEW	AS	SM
A		JUNE 07	ISSUED FOR REVIEW	MC	SM

ORIG SIZE	IN/FILM	FILE NO	SURVEY BOOKS
A1			

TIDE LEVELS						
HAT	MHWS	MHWN	MSL	MLWN	MLWS	LAT
2.87	2.35	1.76	1.44	1.16	0.55	0.03

**GENERAL NOTES**

- 2005 - R12C5 ECW AERIAL PHOTOGRAPHY BASE
- BATHYMETRY DERIVED FROM tn\_hy\_z49.dwg
- LAND CONTOURS DERIVED FROM 4983.dwg

**URS**

LEVEL 3  
 20 TERRACE ROAD  
 EAST PERTH WA 6004 AUSTRALIA  
 TEL: 61 8 9326 0100  
 FAX: 61 8 9326 0296

SCALE: **NTS**

UNLESS OTHERWISE STATED DIMENSIONS IN **m**

HORIZ: EXM 94

VERT: AHD

DESIGNED	S.M
CHECKED	N.S
DRAWN	M.C
CHECKED	S.M
PROJECT MANAGER	N.S

APPROVED

APPROVED

APPROVED

AUTHORISED

MANAGER NEW COASTAL ASSETS

0 10 20 30 40 50 100 150mm

BAR MEASURE INDICATES IF SCALES HAVE BEEN VARIED

Department of Transport

EXMOUTH GULF  
 TANTIBIDDI BOAT RAMP  
 GENERAL NOTES

DRAWING NUMBER **1399 - 02 - 01**

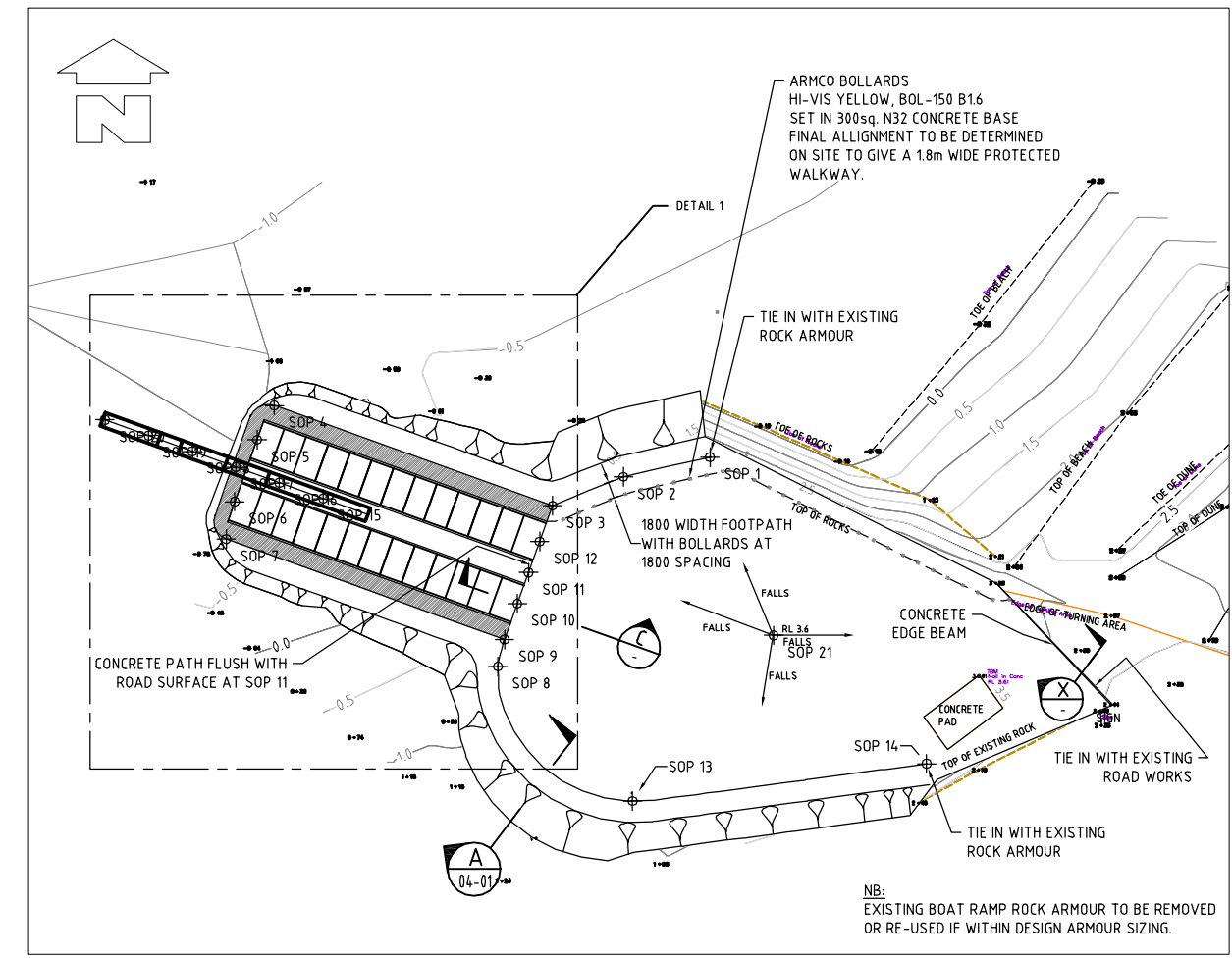
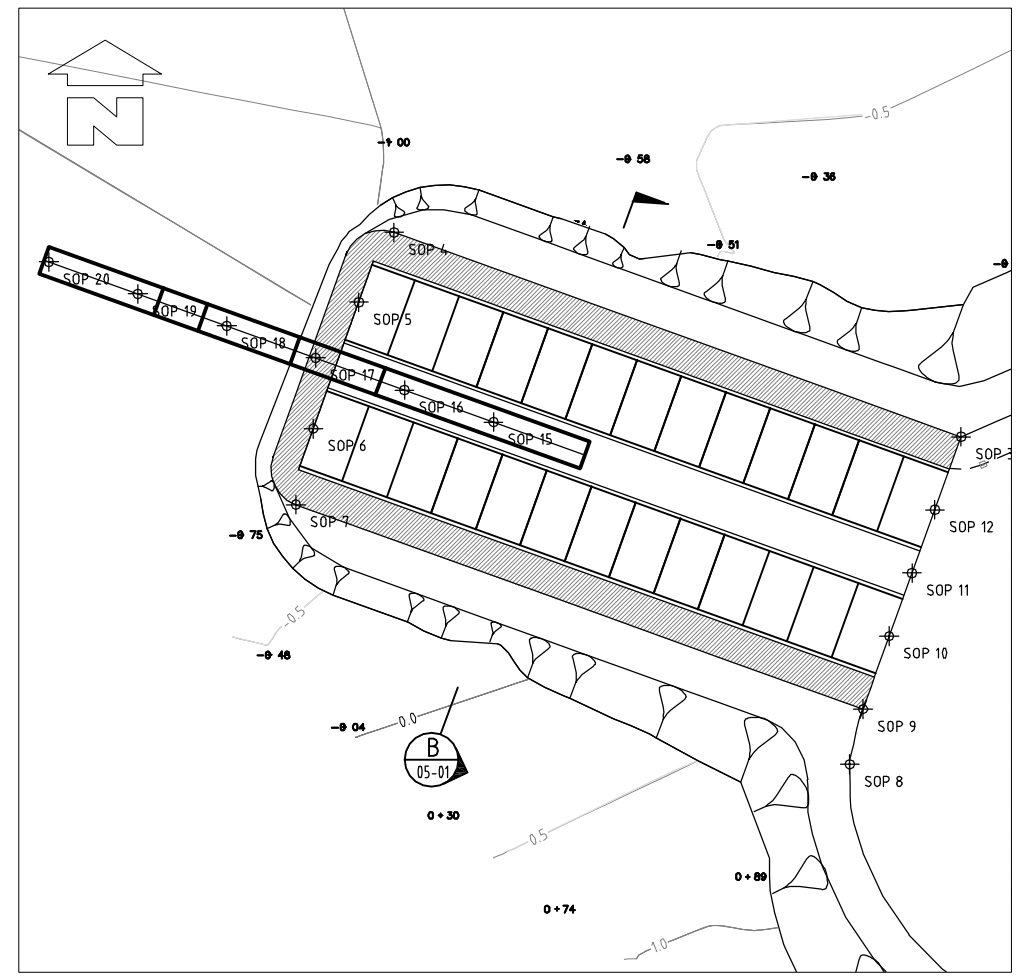
REVN **E**

U:\Jobs\42907658\AMaster\1399-02-01 rev E GENERAL NOTES.dwg

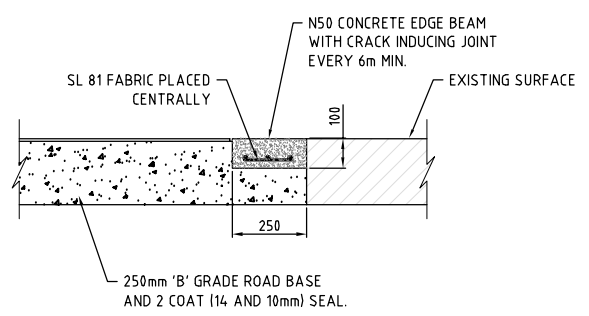
- NOTES:**
- DO NOT SCALE FROM ALL DRAWING.
  - ALL DIMENSIONS ARE IN MILLIMETRES UNLESS NOTED OTHERWISE.
  - ALL LEVEL ARE IN METRES, AND ARE TO AHD, UNLESS NOTED OTHERWISE.
  - THIS DRAWING TO BE READ IN CONJUNCTION WITH ALL OTHER RELEVANT PROJECT DOCUMENTATION AND THE SPECIFICATION.

Setting Out Point Table				
Point #	Point Reference	Elevation (mAHD)	Easting (EXM'94)	Northing (EXM'94)
1	SOP 1	3.400	40861.034	225902.852
2	SOP 2	3.400	40851.700	225900.736
3	SOP 3	3.400	40844.069	225897.617
4	SOP 4	-0.585	40814.077	225908.420
5	SOP 5	-0.648	40812.213	225904.734
6	SOP 6	-0.648	40809.809	225898.054
7	SOP 7	-0.585	40808.887	225894.028
8	SOP 8	3.400	40838.184	225880.306
9	SOP 9	3.400	40838.883	225883.223
10	SOP 10	3.400	40840.266	225887.083
11	SOP 11	3.400	40841.476	225890.420
12	SOP 12	3.400	40842.680	225893.763
13	SOP 13	3.400	40852.688	225865.807
14	SOP 14	3.400	40884.387	225869.825
15	SOP 15	0.717	40819.331	225898.395
16	SOP 16	0.717	40814.631	225900.090
17	SOP 17	0.241	40809.928	225901.784
18	SOP 18	0.097	40805.224	225903.479
19	SOP 19	-0.213	40800.520	225905.173
20	SOP 20	-0.213	40795.815	225906.868
21	SOP 21	3.600	40867.895	225883.653

**NOTE:**  
SOPs 15-20 ARE FOR JETTY PILES, AND ELEVATIONS STATED FOR THESE ARE FOR NOMINAL PILE CUT-OFF LEVELS, TAKEN AS UNDERSIDE OF PILE CAP PLATE, UNDER CROSSHEADS. FINAL LEVELS TO BE CONFIRMED PRIOR TO CONSTRUCTION. CONTRACTOR TO CONFIRM SETTING OUT POINTS ON SITE PRIOR TO CONSTRUCTION.

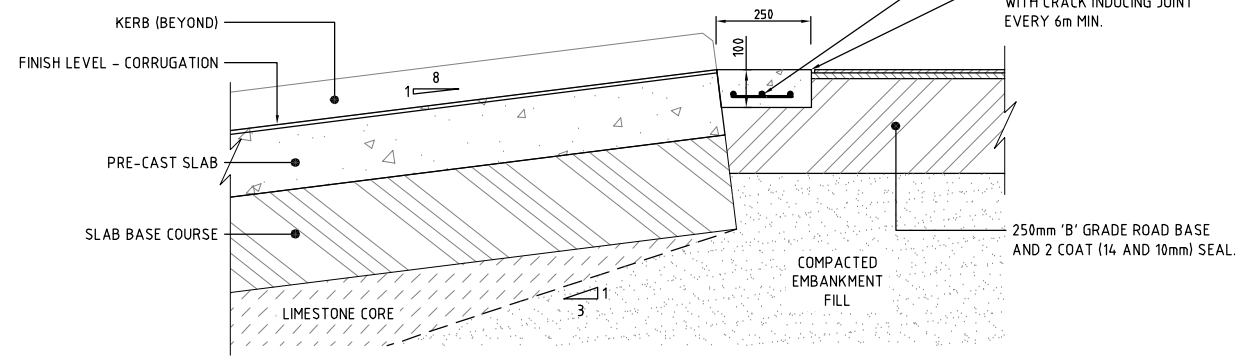


**DETAIL 1**  
SCALE 1:200

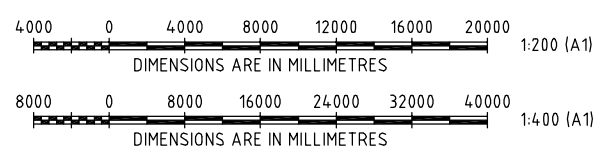


**SECTION X**  
NTS

**PLAN**  
SCALE 1:400



**SECTION C**  
SCALE 1:10



REV#	ZONE	DATE	ISSUED FOR	AMENDMENT	DRN	DESIGN APPROVAL
G		14.04.11	RE ISSUED FOR TENDER		SO'B	SM
F		13.01.11	RE ISSUED FOR TENDER		AS	NS
E		11.01.11	ISSUED FOR TENDER		AS	NS
D		15.12.10	ISSUED FOR REVIEW		SO'B	
C		10.12.10	ISSUED FOR REVIEW		SO'B	

**GENERAL NOTES**

- 2005 - R12C5.ECW AERIAL PHOTOGRAPHY BASE
- BATHYMETRY DERIVED FROM tn\_hy\_z49.dwg
- LAND CONTOURS DERIVED FROM 4983.dwg

**TIDE LEVELS**

HAT	MHWs	MHYMN	MSL	MLWN	MLWS	LAT
2.87	2.35	1.76	1.44	1.16	0.55	0.03

**URS**

LEVEL 3  
20 TERRACE ROAD  
EAST PERTH WA 6004 AUSTRALIA  
TEL: 61 8 9326 0100  
FAX: 61 8 9326 0296

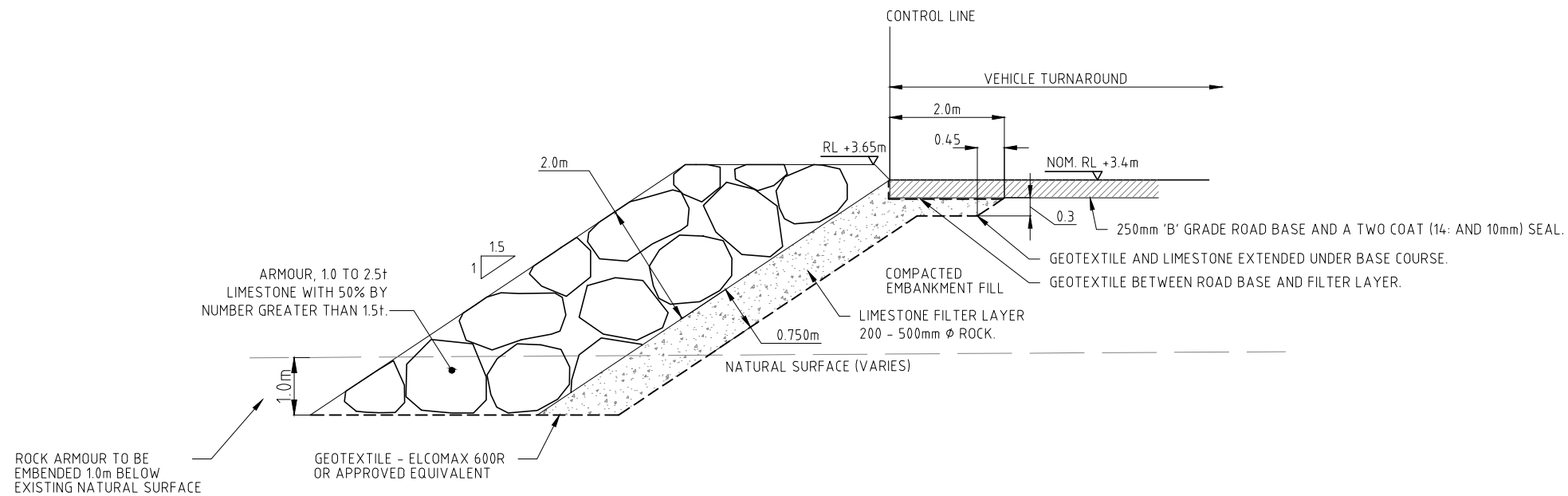
SCALE:	DESIGNED	APPROVED
AS SHOWN @ A1	S.M	
UNLESS OTHERWISE STATED DIMENSIONS IN mm	CHECKED N.S	APPROVED
HORIZ: EXM 94	DRAWN M.C	APPROVED
VERT: AHD	CHECKED S.M	APPROVED
	PROJECT MANAGER N.S	AUTHORISED
		MANAGER NEW COASTAL ASSETS

Department for Planning and Infrastructure

EXMOUTH  
TANTABIDDI BOAT RAMP  
GENERAL ARRANGEMENT & SITE LAYOUT

DRAWING NUMBER **1399 - 03 - 01**

REV# G



SECTION A  
SCALE 1:50

REV	ZONE	DATE	AMENDMENT	DRN	DESIGN APPROVAL
E		14.04.11	ISSUED FOR TENDER	S0'B	SM
D		23.02.11	ISSUED FOR TENDER	AS	NS
C		13.01.11	ISSUED FOR TENDER	AS	NS
B		06.12.10	RE ISSUED FOR REVIEW	S0'B	SM
A		JUNE 07	ISSUED FOR REVIEW	MC	SM

**GENERAL NOTES**

- 2005 - R12C5.ECW AERIAL PHOTOGRAPHY BASE
- BATHYMETRY DERIVED FROM tn\_hy\_z49.dwg
- LAND CONTOURS DERIVED FROM 4983.dwg

TIDE LEVELS						
HAT	MHWs	MHWN	MSL	MLWN	MLWS	LAT
2.87	2.35	1.76	1.44	1.16	0.55	0.03

**URS**

LEVEL 3  
20 TERRACE ROAD  
EAST PERTH WA 6004 AUSTRALIA  
TEL: 61 8 9326 0100  
FAX: 61 8 9326 0296

SCALE: AS SHOWN @ A1

UNLESS OTHERWISE STATED DIMENSIONS IN mm

HORIZ: EXM 94

VERT: AHD

DESIGNED	S.M
CHECKED	N.S
DRAWN	M.C
CHECKED	S.M
PROJECT MANAGER	N.S

0 10 20 30 40 50 100 150mm

BAR MEASURE INDICATES IF SCALES HAVE BEEN VARIED

APPROVED	
APPROVED	
APPROVED	
AUTHORISED	

Department of Transport

EXMOUTH  
TANTABIDDI BOAT RAMP  
SECTION A

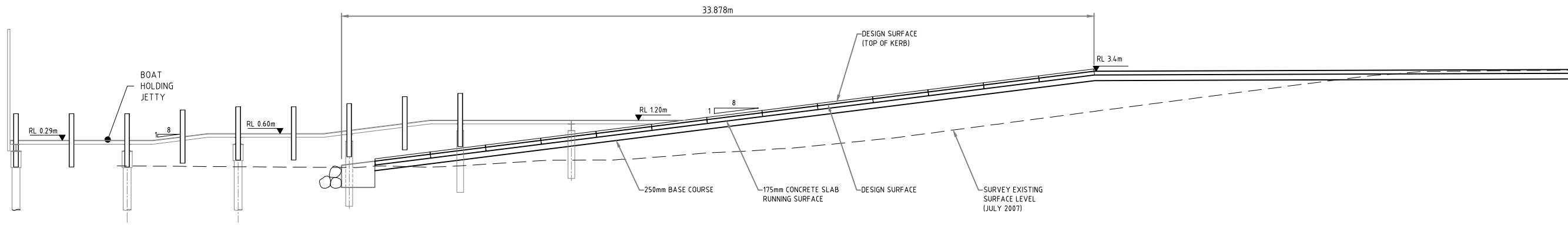
DRAWING NUMBER 1399 - 04 - 01

MANAGER NEW COASTAL ASSETS

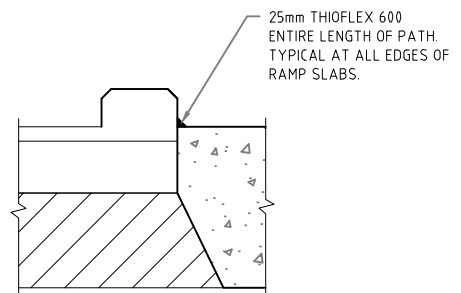
REVN E



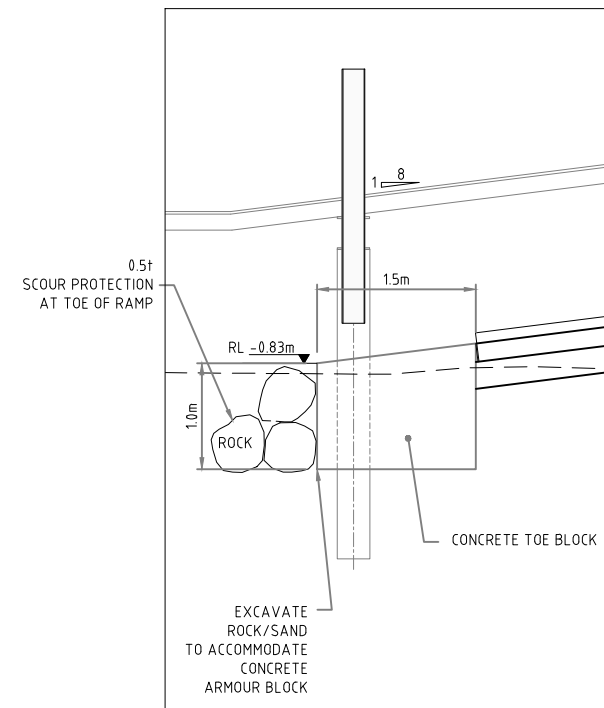
TIDE BAR (AHD)						
HAT	1.03					
MHWS	0.59					
MSL	0.06					
MLWN	-0.14					
MLWS	-0.47					
LAT	-0.91					



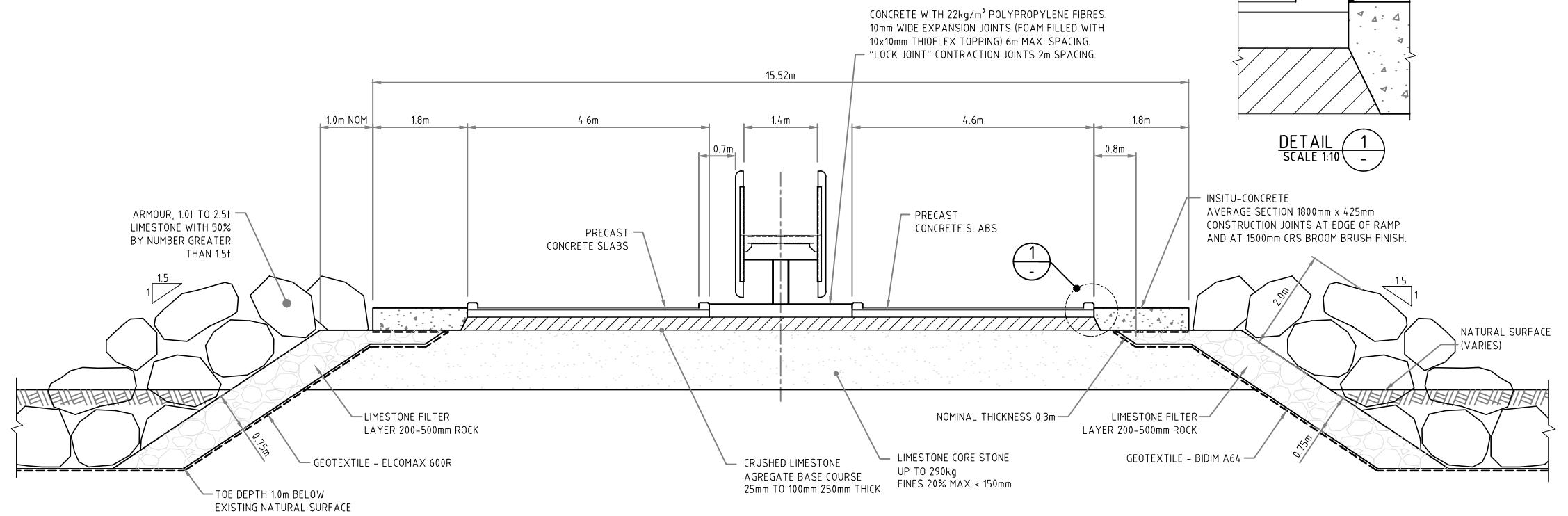
**BOAT RAMP LONGITUDINAL SECTION**  
SCALE 1:100



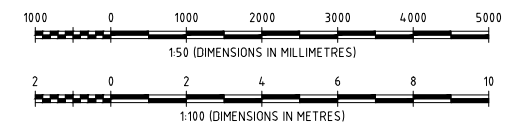
**DETAIL 1**  
SCALE 1:10



**ENLARGEMENT**  
DIAGRAMMATIC



**SECTION B**  
SCALE 1:50



REV	ZONE	DATE	AMENDMENT	DRN	DESIGN APPROVAL
G		14.04.11	RE ISSUED FOR TENDER	S0'B	SM
F		07.02.11	RE ISSUED FOR TENDER	AS	NS
E		12.01.11	ISSUED FOR TENDER	AS	NS
D		14.12.10	RE ISSUED FOR REVIEW	AS	SM
C		09.12.10	RE ISSUED FOR REVIEW	S0'B	SM

GENERAL NOTES						
1. 2005 - R12C5.ECW AERIAL PHOTOGRAPHY BASE						
2. BATHYMETRY DERIVED FROM tn_hy_z49.dwg						
3. LAND CONTOURS DERIVED FROM 4983.dwg						

TIDE LEVELS						
HAT	MHWS	MHWN	MSL	MLWN	MLWS	LAT
2.478	2.35	1.76	1.44	1.16	0.55	0.03

**URS**

LEVEL 3  
20 TERRACE ROAD  
EAST PERTH WA 6004 AUSTRALIA  
TEL: 61 8 9326 0100  
FAX: 61 8 9326 0296

SCALE:	AS MARKED @ A1
HORIZ:	EXM 94
VERT:	AHD

DESIGNED	S.M
CHECKED	N.S
DRAWN	M.C
CHECKED	S.M
PROJECT MANAGER	N.S

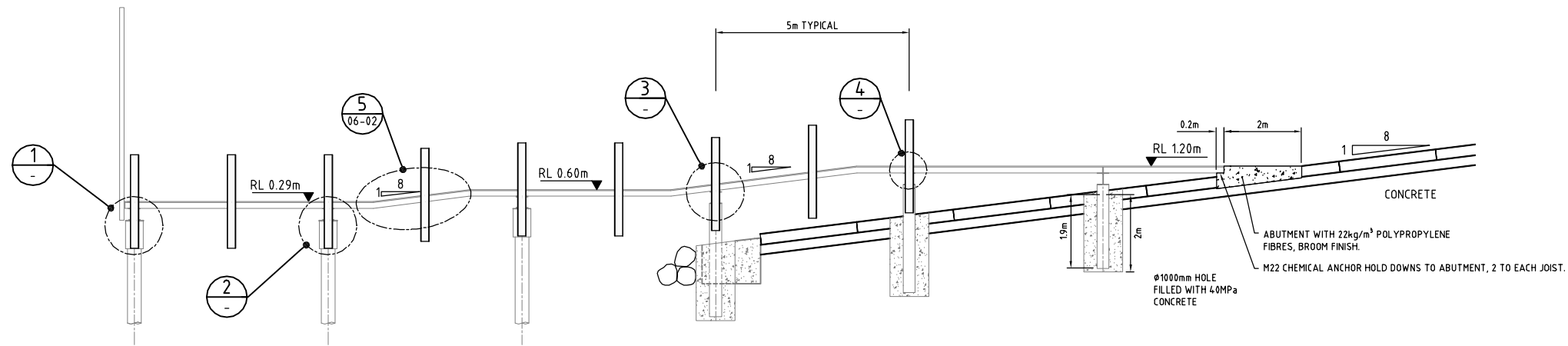
Department of Transport

EXMOUTH  
TANTABIDDI BOAT RAMP  
LONGITUDINAL & TYPICAL SECTIONS

DRAWING NUMBER **1399 - 05 - 01**

MANAGER NEW COASTAL ASSETS

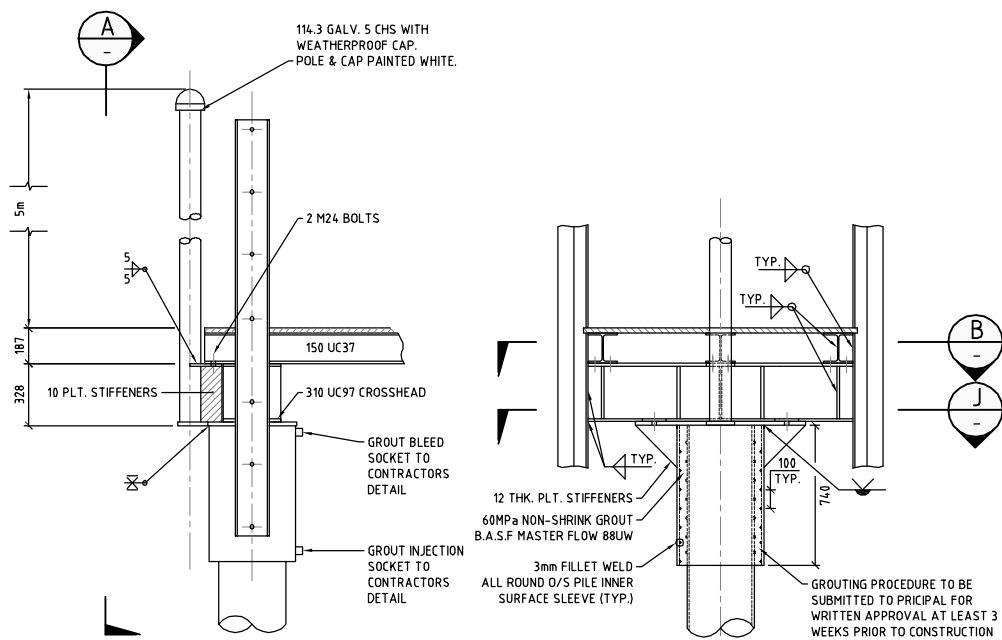




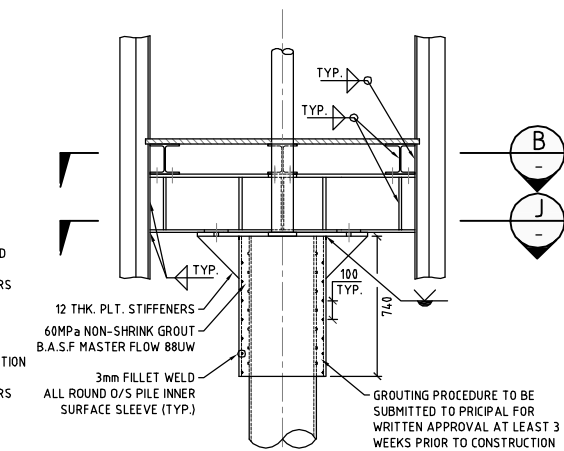
NB. SUB-SURFACE GROUND CONDITIONS ARE NOT KNOWN. PILE MAY REQUIRE GROUT INJECTION.

ELEVATION  
SCALE 1:75

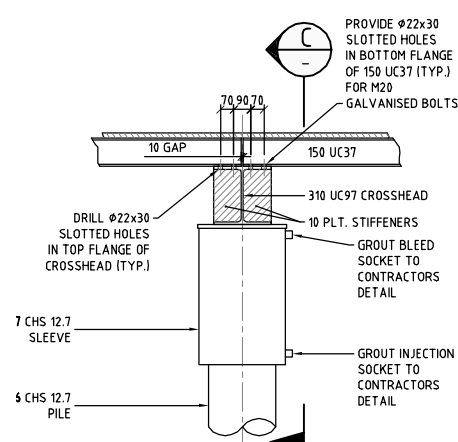
**CHS PILE INSTALLATION**  
SUB SURFACE CONDITIONS ARE NOT KNOWN. PILES SHALL BE DRILLED AND GROUTED 2.5m INTO COMPETENT ROCK (-1MPa) OR 5.5m PENETRATION INTO SAND. GROUT INJECTION INTO SURROUNDING SAND MAY BE REQUIRED AT THE DISCRETION OF THE SUPERINTENDENT BASED ON CONDITIONS ENCOUNTERED ON SITE.



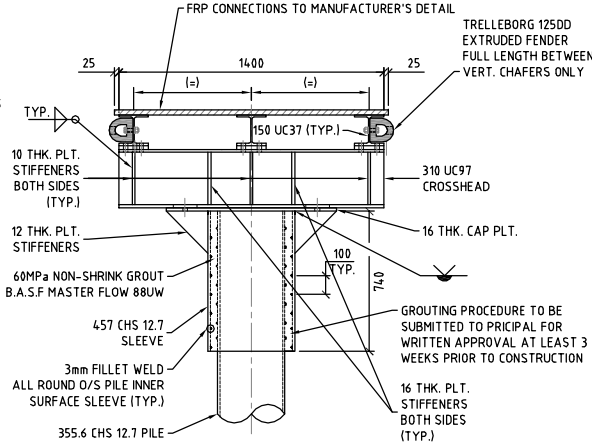
DETAIL  
SCALE: 1:20



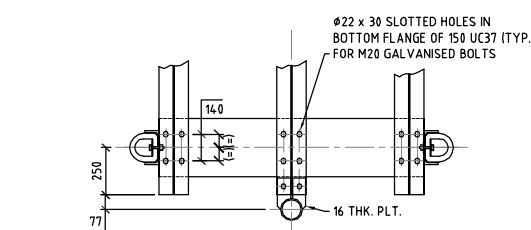
SECTION  
SCALE: 1:20



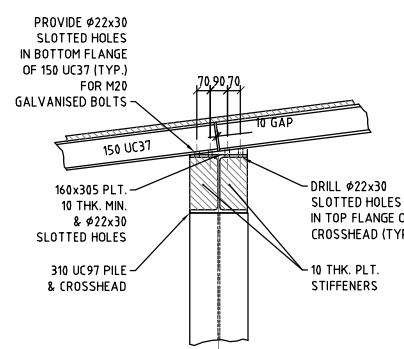
DETAIL  
SCALE: 1:20



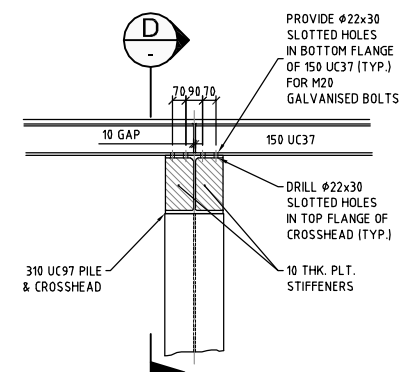
SECTION  
SCALE: 1:20



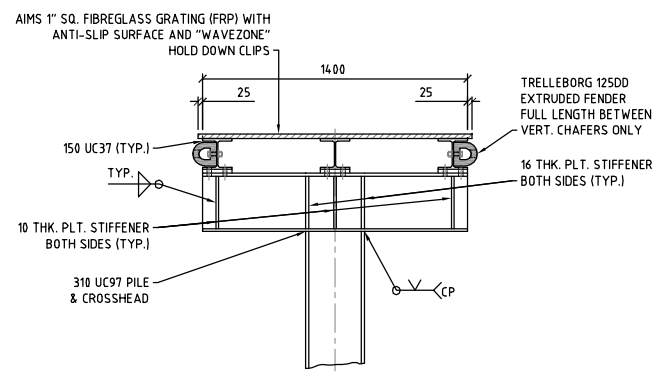
SECTION  
SCALE: 1:20



DETAIL  
SCALE: 1:20

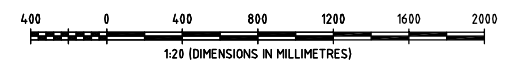


DETAIL  
SCALE: 1:20



SECTION  
SCALE: 1:20

NB. FENDERS/CHAFERS OMITTED FOR CLARITY ON DETAILS 2-5.



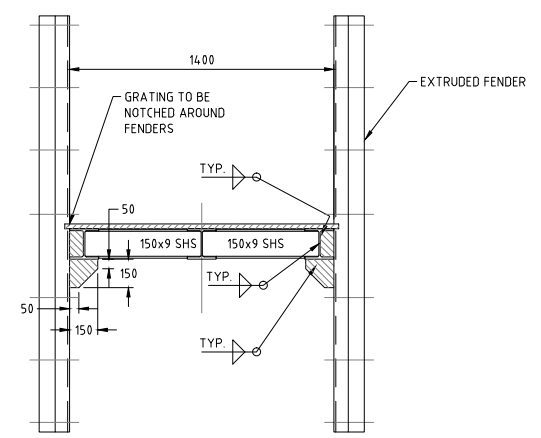
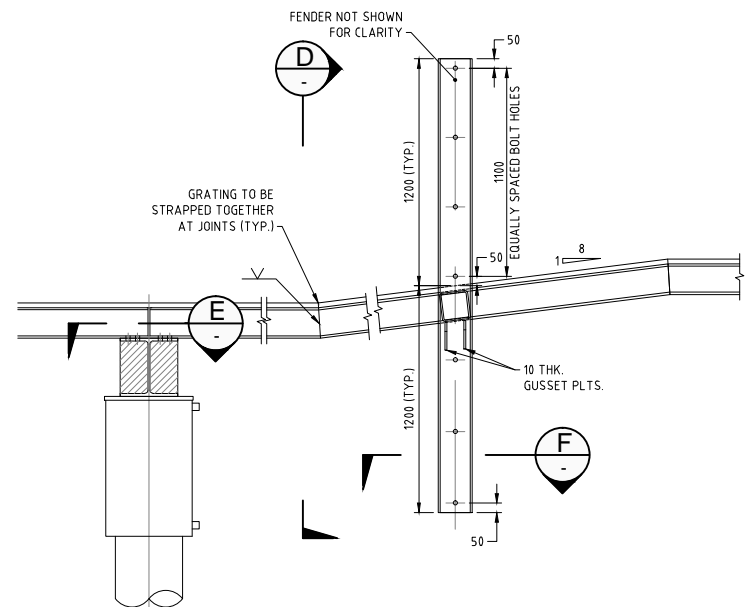
G	14.04.11	ISSUED FOR TENDER	S0'B	SM	
F	23.02.11	ISSUED FOR TENDER	AS	NS	
E	13.01.11	ISSUED FOR TENDER	AS	NS	
D	23.12.10	RE ISSUED FOR REVIEW	AS	NS	
C	17.12.10	RE ISSUED FOR REVIEW	AS	NS	
REV#	ZONE	DATE	AMENDMENT	DRN	DESIGN APPROVAL
ORIG. SIZE	A1	FILE NO.	SURVEY BOOKS		

GENERAL NOTES

**URS**  
LEVEL 3  
20 TERRACE ROAD  
EAST PERTH WA 6004 AUSTRALIA  
TEL: 61 8 9326 0100  
FAX: 61 8 9326 0296

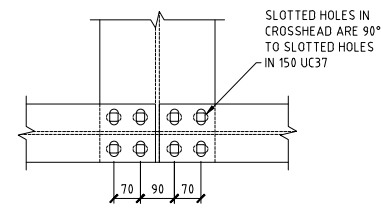
SCALE:	AS MARKED @ A1	DESIGNED	S.M	APPROVED	
	UNLESS OTHERWISE STATED DIMENSIONS IN mm	CHECKED	NS	APPROVED	
HORIZ:	EXM 94	DRAWN	M.C	APPROVED	
VERT:	AHD	CHECKED	S.M.	APPROVED	
		PROJECT MANAGER	N.S	AUTHORISED	
				MANAGER NEW COASTAL ASSETS	

Department of Transport  
EXMOUTH  
TANTABIDDI BOAT RAMP  
PEDESTRIAN RAMP 1 of 2  
DRAWING NUMBER 1399 - 06 - 01  
REV# G

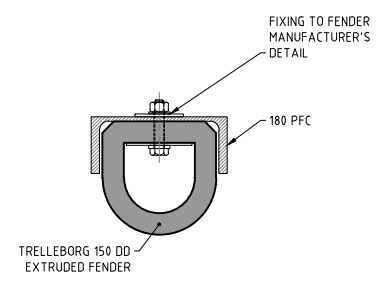


SECTION D  
SCALE: 1:20

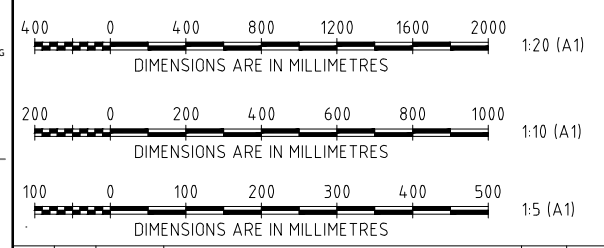
DETAIL 5  
SCALE: 1:20



SECTION E  
SCALE: 1:10



SECTION F  
SCALE: 1:5



E	14.04.11	ISSUED FOR TENDER	S0'B	NS	
D	13.01.11	ISSUED FOR TENDER	AS	NS	
C	17.12.10	RE-ISSUED FOR REVIEW	S0'B		
B	07.12.10	RE-ISSUED FOR REVIEW	S0'B		
A	JUNE 07	ISSUED FOR REVIEW	MC		
REV#	ZONE	DATE	AMENDMENT	DRN	DESIGN APPROVAL
ORIG SIZE	IN/FILM	FILE NO	SURVEY BOOKS		
A1					

GENERAL NOTES

**URS**

LEVEL 3  
20 TERRACE ROAD  
EAST PERTH WA 6004 AUSTRALIA  
TEL: 61 8 9326 0100  
FAX: 61 8 9326 0296

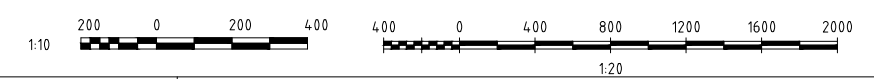
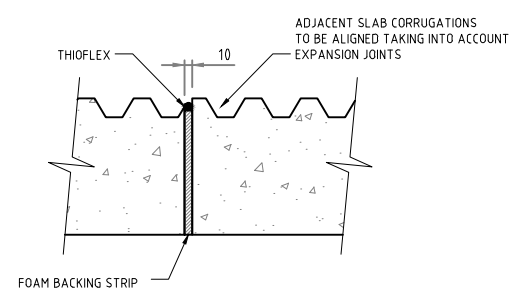
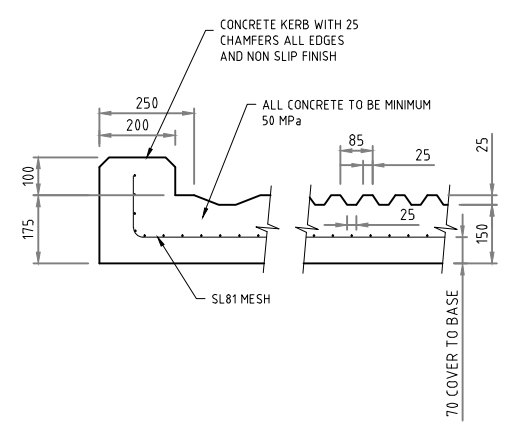
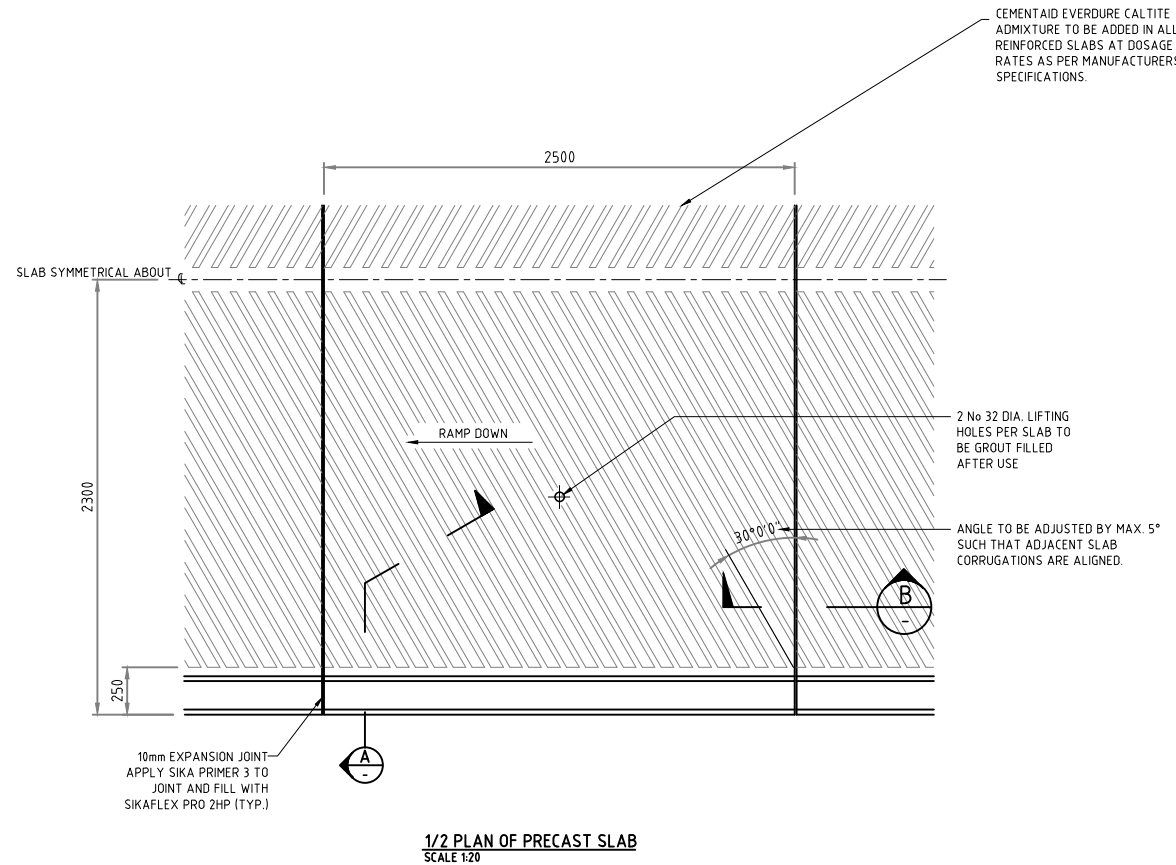
SCALE:	AS MARKED @ A1	DESIGNED	S.M	APPROVED	
		CHECKED	N.S.	APPROVED	
	UNLESS OTHERWISE STATED DIMENSIONS IN m	DRAWN	M.C	APPROVED	
HORIZ:	EXM 94	CHECKED	S.M	APPROVED	
VERT:	AHD	PROJECT MANAGER	N.S	AUTHORISED	
				MANAGER NEW COASTAL ASSETS	

Department of Transport

EXMOUTH  
TANTABIDDI BOAT RAMP  
PEDESTRIAN RAMP 2 of 2

DRAWING NUMBER 1399-06-02

REVN E



REV#	ZONE	DATE	AMENDMENT	DRN	DESIGN APPROVAL
E		14.04.11	ISSUED FOR TENDER	S0'B	SM
D		13.01.11	ISSUED FOR TENDER	AS	NS
C		14.12.10	RE ISSUED FOR REVIEW	AS	SM
B		07.12.10	RE ISSUED FOR REVIEW	AS	SM
A		JUNE 07	ISSUED FOR REVIEW	MC	SM
ORIG SIZE	M/FILM	FILE NO	SURVEY BOOKS		
A1					

**GENERAL NOTES**

- 2005 - R12C5.ECW AERIAL PHOTOGRAPHY BASE
- BATHYMETRY DERIVED FROM tn\_hy\_z49.dwg
- LAND CONTOURS DERIVED FROM 4983.dwg

TIDE LEVELS						
HAT	MHW	MHWN	MSL	MLWN	MLWS	LAT
2.478	2.35	1.76	1.44	1.16	0.55	0.03

**URS**

LEVEL 3  
20 TERRACE ROAD  
EAST PERTH WA 6004 AUSTRALIA  
TEL: 61 8 9326 0100  
FAX: 61 8 9326 0296

SCALE: AS SHOWN @ A1

UNLESS OTHERWISE STATED DIMENSIONS IN mm

HORIZ: EXM 94

VERT: AHD

DESIGNED	S.M
CHECKED	N.S
DRAWN	M.C
CHECKED	S.M
PROJECT MANAGER	N.S

0 10 20 30 40 50 100 150mm

BAR MEASURE INDICATES IF SCALES HAVE BEEN VARIED

APPROVED	
APPROVED	
APPROVED	
AUTHORISED	
MANAGER NEW COASTAL ASSETS	

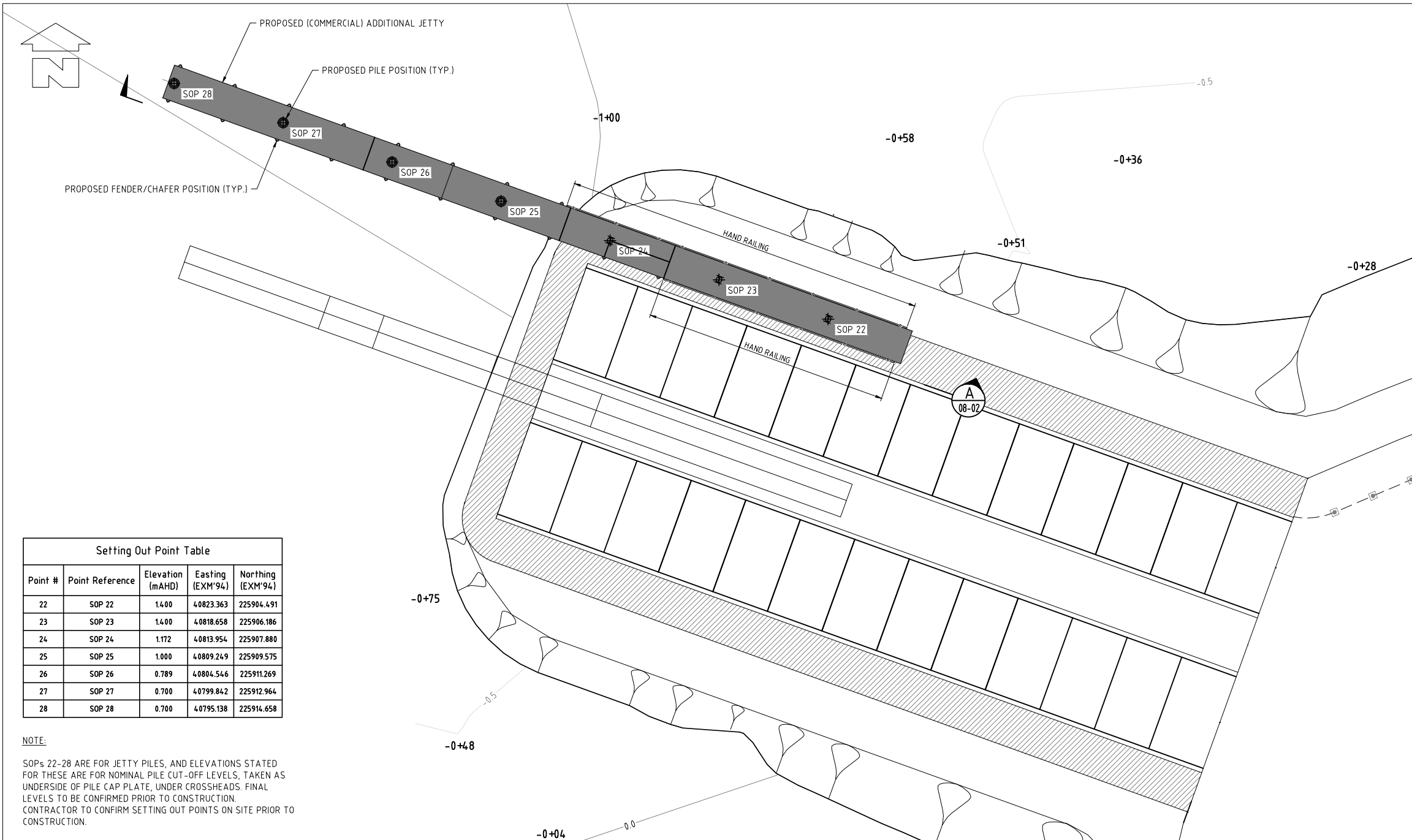
Department of Transport

EXMOUTH  
TANTABIDDI BOAT RAMP  
PRE-CAST SLAB DETAILS

DRAWING NUMBER **1399 - 07 - 01**

REVN **E**

Government of Western Australia



**Setting Out Point Table**

Point #	Point Reference	Elevation (mAHD)	Easting (EXM'94)	Northing (EXM'94)
22	SOP 22	1.400	40823.363	225904.491
23	SOP 23	1.400	40818.658	225906.186
24	SOP 24	1.172	40813.954	225907.880
25	SOP 25	1.000	40809.249	225909.575
26	SOP 26	0.789	40804.546	225911.269
27	SOP 27	0.700	40799.842	225912.964
28	SOP 28	0.700	40795.138	225914.658

**NOTE:**  
 SOPs 22-28 ARE FOR JETTY PILES, AND ELEVATIONS STATED FOR THESE ARE FOR NOMINAL PILE CUT-OFF LEVELS, TAKEN AS UNDERSIDE OF PILE CAP PLATE, UNDER CROSSHEADS. FINAL LEVELS TO BE CONFIRMED PRIOR TO CONSTRUCTION. CONTRACTOR TO CONFIRM SETTING OUT POINTS ON SITE PRIOR TO CONSTRUCTION.

- NOTES:**
- DO NOT SCALE FROM ALL DRAWING.
  - ALL DIMENSIONS ARE IN MILLIMETRES UNLESS NOTED OTHERWISE.
  - ALL LEVEL ARE IN METRES, AND ARE TO AHD, UNLESS NOTED OTHERWISE.
  - THIS DRAWING TO BE READ IN CONJUNCTION WITH ALL OTHER RELEVANT PROJECT DOCUMENTATION AND THE SPECIFICATION.
  - HANDRAILING:
    - GALVANISED HAND RAILING TO BE WHIP BLASTED AND PAINTED WITH HIGH VISIBILITY SAFETY YELLOW PAINT.
    - GALVANISED BOLTS, WASHERS AND HANDRAIL TO BE ELECTRICALLY DISCONNECTED FROM THE UB THROUGH USE OF A NYLON TOP HAT AND WASHER.
    - ALL HANDRAIL TO STANCHION CONNECTIONS TO BE SEAL WELDED AND TREATED ACCORDING TO THE SPECIFICATION.

**PLAN**  
SCALE 1:100



REV#		ZONE	DATE	ISSUED FOR REVIEW	SO'B	SM
A			14.04.11			
ORIG SIZE	M/FILM	FILE NO	SURVEY BOOKS		DRN	DESIGN APPROVAL
A1						

- GENERAL NOTES**
- 2005 - R12C5.ECW AERIAL PHOTOGRAPHY BASE
  - BATHYMETRY DERIVED FROM tn\_hy\_z49.dwg
  - LAND CONTOURS DERIVED FROM 4983.dwg

TIDE LEVELS						
HAT	MHWS	MHWN	MSL	MLWN	MLWS	LAT
2.87	2.35	1.76	1.44	1.16	0.55	0.03



LEVEL 3  
 20 TERRACE ROAD  
 EAST PERTH WA 6004 AUSTRALIA  
 TEL: 61 8 9326 0100  
 FAX: 61 8 9326 0296

SCALE:	AS SHOWN @ A1
UNLESS OTHERWISE STATED DIMENSIONS IN mm	
HORIZ:	EXM 94
VERT:	AHD

DESIGNED	S.M	APPROVED	
CHECKED	N.S	APPROVED	
DRAWN	SO'B	APPROVED	
CHECKED	S.M	APPROVED	
PROJECT MANAGER	N.S	AUTHORISED	

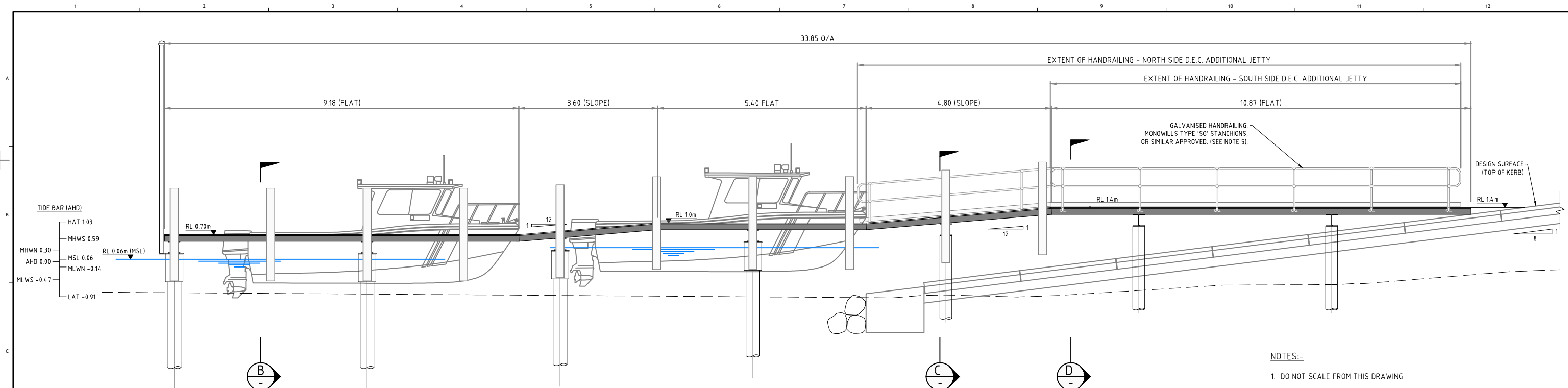
**Department for Planning and Infrastructure**

EXMOUTH  
 TANTABIDDI BOAT RAMP - D.E.C. ADDITIONAL JETTY  
 GENERAL ARRANGEMENT

**DRAWING NUMBER 1399 - 08 - 01**

REVN A

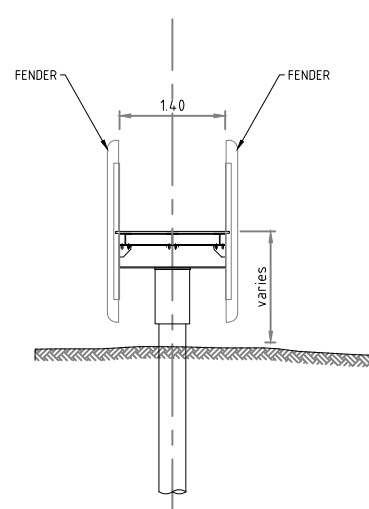




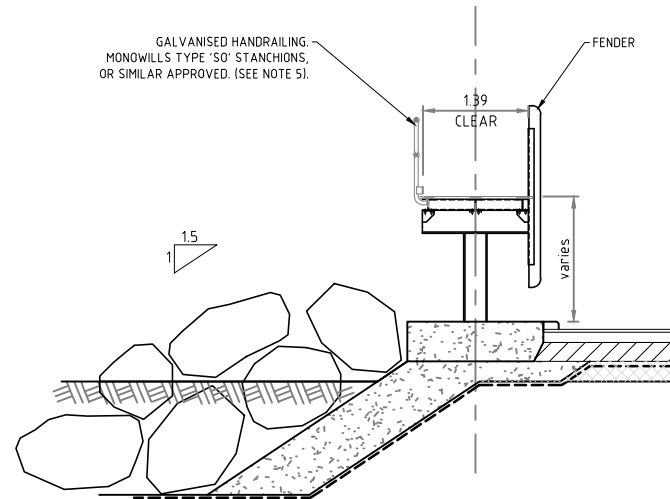
SECTION **A** D.E.C. JETTY LONGITUDINAL SECTION  
SCALE: 1:50 (A1) 08-01

NOTES:-

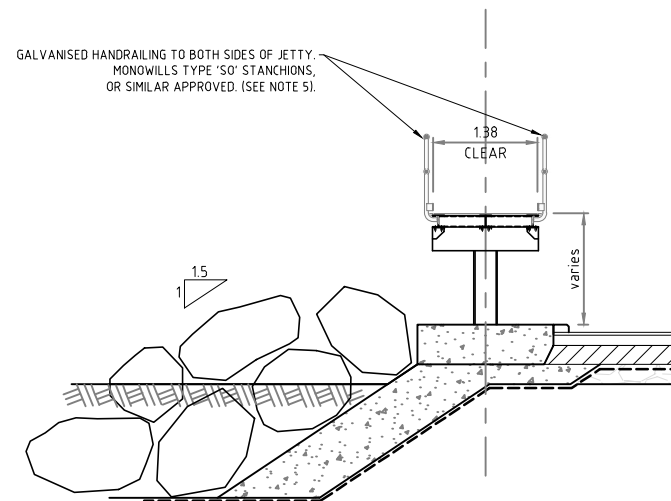
1. DO NOT SCALE FROM THIS DRAWING.
2. ALL DIMENSIONS ARE IN METRES UNLESS NOTED OTHERWISE.
3. ALL LEVELS ARE IN METRES, AND ARE TO AUSTRALIAN HEIGHT DATUM (AHD) UNLESS NOTED OTHERWISE.
4. THIS DRAWING TO BE READ IN CONJUNCTION WITH ALL OTHER RELEVANT SCHEME DOCUMENTATION AND THE SPECIFICATION.
5. HANDRAILING:
  - (i) GALVANISED HAND RAILING TO BE WHIP BLASTED AND PAINTED WITH HIGH VISIBILITY SAFETY YELLOW PAINT.
  - (ii) GALVANISED BOLTS, WASHERS AND HANDRAIL TO BE ELECTRICALLY DISCONNECTED FROM THE UB THROUGH USE OF A NYLON TOP HAT AND WASHER.
  - (iii) ALL HANDRAIL TO STANCHION CONNECTIONS TO BE SEAL WELDED AND TREATED ACCORDING TO THE SPECIFICATION.



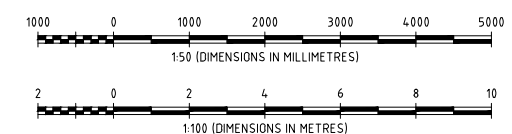
SECTION 'B'  
SCALE 1:50



SECTION 'C'  
SCALE 1:50



SECTION 'D'  
SCALE 1:50



GENERAL NOTES

1. 2005 - R12C5:ECW AERIAL PHOTOGRAPHY BASE
2. BATHYMETRY DERIVED FROM tn\_hy\_z49.dwg
3. LAND CONTOURS DERIVED FROM 4.983.dwg

TIDE LEVELS						
HAT	MHWS	MHWN	MSL	MLWN	MLWS	LAT
2.478	2.35	1.76	1.44	1.16	0.55	0.03



LEVEL 3  
20 TERRACE ROAD  
EAST PERTH WA 6004 AUSTRALIA  
TEL: 61 8 9326 0100  
FAX: 61 8 9326 0296

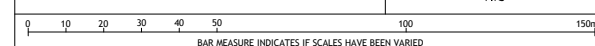
SCALE:

AS MARKED @ A1

UNLESS OTHERWISE STATED DIMENSIONS IN m

HORIZ: EXM 94

VERT: AHD



DESIGNED	S.M
CHECKED	N.S
DRAWN	SO'B
CHECKED	S.M
PROJECT MANAGER	N.S

APPROVED	
APPROVED	
APPROVED	
AUTHORISED	

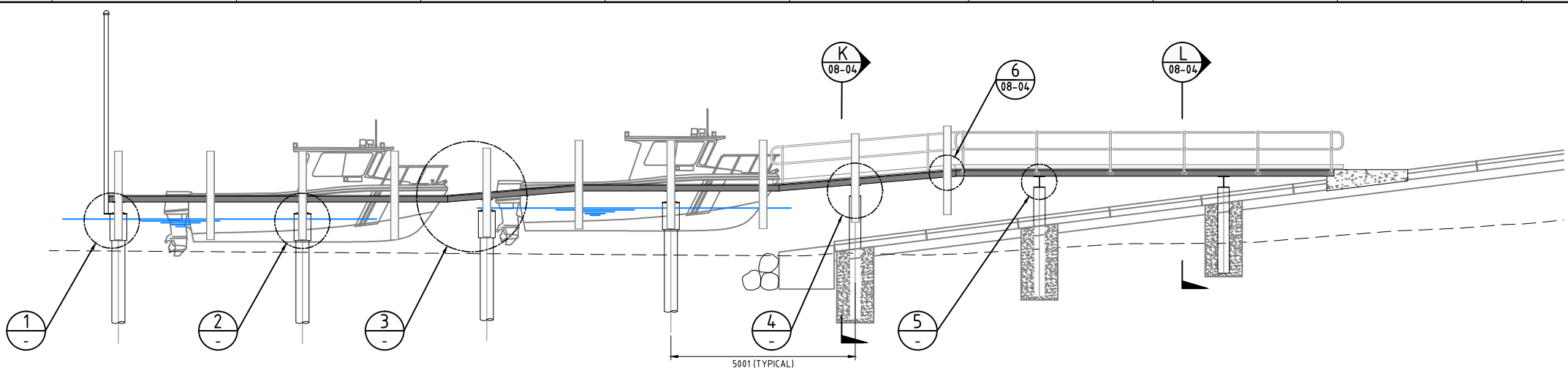
Department of Transport

EXMOUTH  
TANTABIDDI BOAT RAMP - D.E.C. ADDITIONAL JETTY  
LONGITUDINAL & TYPICAL SECTIONS

DRAWING NUMBER 1399 - 08 - 02



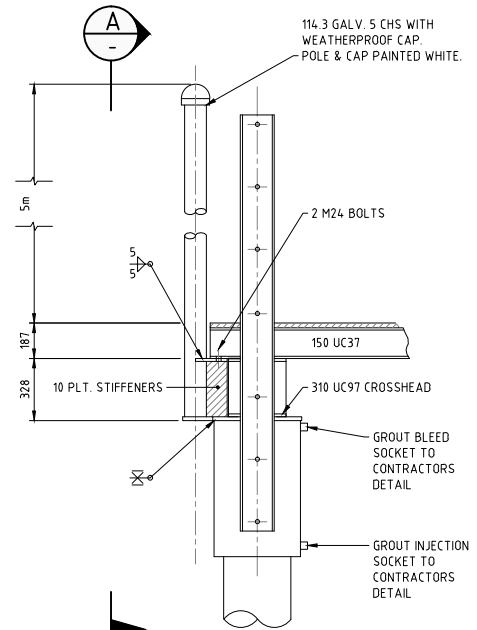
REVN A



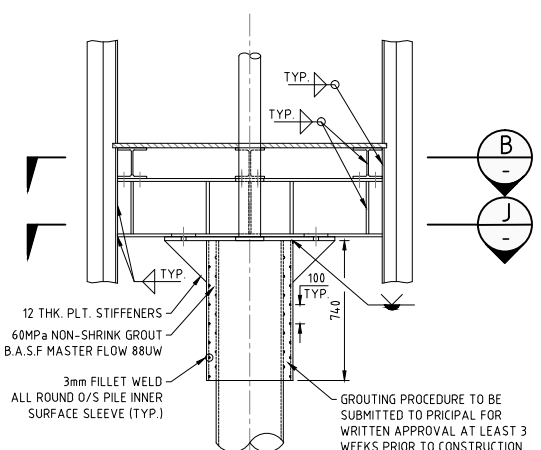
**CHS PILE INSTALLATION - D.E.C. JETTY**  
 SUB SURFACE CONDITIONS ARE NOT KNOWN. PILES SHALL BE DRILLED AND GROUTED 2.5m INTO COMPETENT ROCK (> 1MPa) OR 6.5m PENETRATION INTO SAND. GROUT INJECTION INTO SURROUNDING SAND MAY BE REQUIRED AT THE DISCRETION OF THE SUPERINTENDENT BASED ON CONDITIONS ENCOUNTERED ON SITE.

NB. SUB-SURFACE GROUND CONDITIONS ARE NOT KNOWN. PILE MAY REQUIRE GROUT INJECTION.

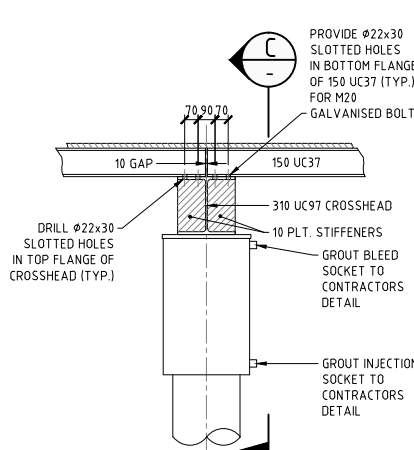
**ELEVATION**  
SCALE 1:75



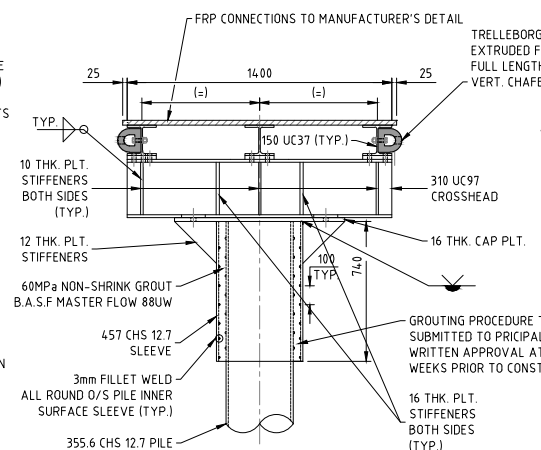
**DETAIL**  
SCALE: 1:20



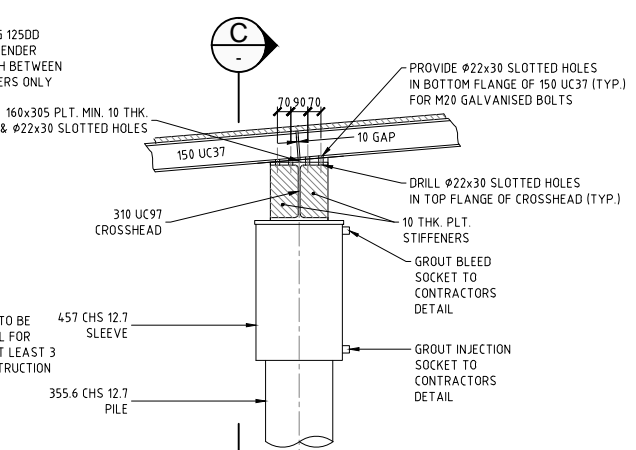
**SECTION**  
SCALE: 1:20



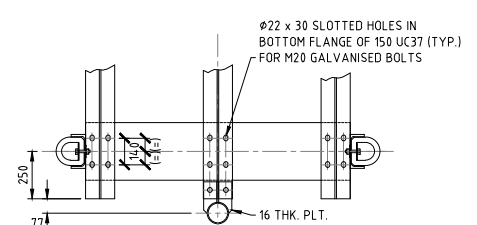
**DETAIL**  
SCALE: 1:20



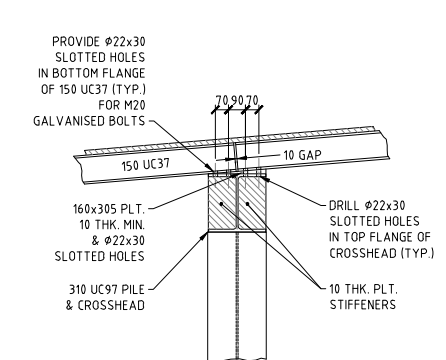
**SECTION**  
SCALE: 1:20



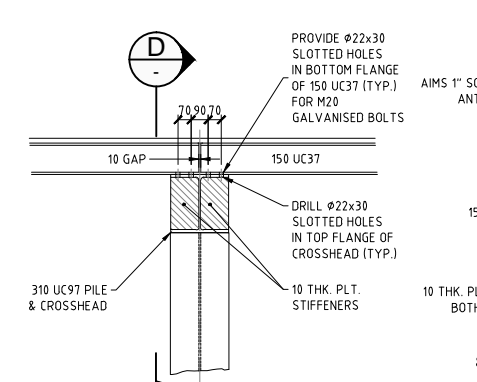
**DETAIL**  
SCALE: 1:20



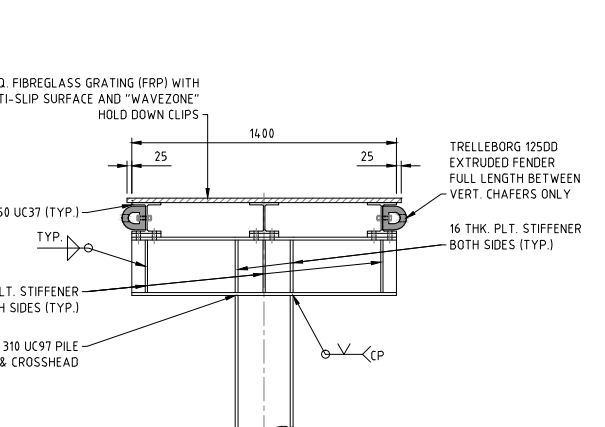
**SECTION**  
SCALE: 1:20



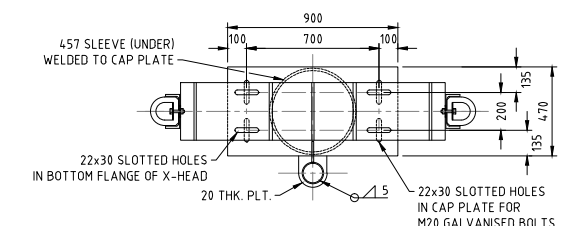
**DETAIL**  
SCALE: 1:20



**DETAIL**  
SCALE: 1:20

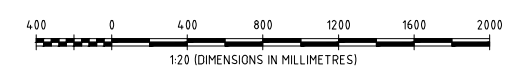


**SECTION**  
SCALE: 1:20



**SECTION**  
SCALE: 1:20

NB. FENDERS/CHAFERS OMITTED FOR CLARITY ON DETAILS 2-5.



REV#	ZONE	DATE	AMENDMENT	DRN	DESIGN APPROVAL
A		14.04.11	ISSUED FOR REVIEW	SO'B	NS
ORIG SIZE	A1		FILE NO	SURVEY BOOKS	

**GENERAL NOTES**

**URS**  
 LEVEL 3  
 20 TERRACE ROAD  
 EAST PERTH WA 6004 AUSTRALIA  
 TEL: 61 8 9326 0100  
 FAX: 61 8 9326 0296

SCALE: AS MARKED @ A1	DESIGNED: S.M.	APPROVED:
UNLESS OTHERWISE STATED DIMENSIONS IN mm	CHECKED: NS	APPROVED:
HORIZ: EXM 94	DRAWN: SO'B	APPROVED:
VERT: AHD	CHECKED: S.M.	APPROVED:
	PROJECT MANAGER: N.S.	AUTHORISED:
		MANAGER NEW COASTAL ASSETS

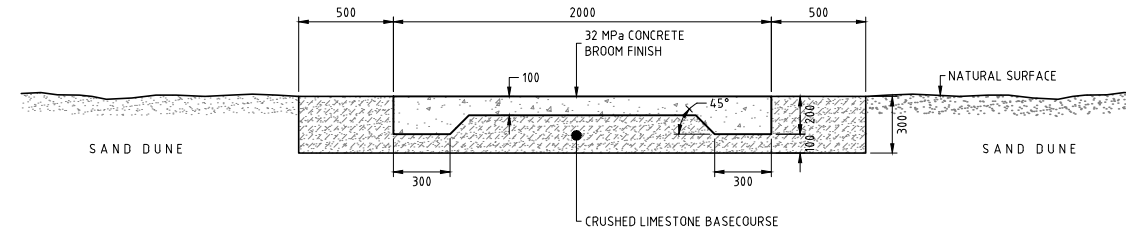
**Department of Transport**  
 EXMOUTH  
 TANTABIDDI BOAT RAMP - D.E.C. ADDITIONAL JETTY  
 STEELWORK CONNECTION DETAILS, SHEET 1 OF 2.  
 DRAWING NUMBER: 1399 - 08 - 03  
 REV# A



**NOTES:**

1. DO NOT SCALE FROM THIS DRAWING.
2. ALL DIMENSIONS ARE IN MILLIMETRES UNLESS NOTED OTHERWISE.
3. THIS DRAWING TO BE READ IN CONJUNCTION WITH ALL OTHER RELEVANT SCHEME DRAWINGS AND THE SPECIFICATION.
4. FOOTPATH TO TIE IN WITH BOLLARD PROTECTED PATH SHOWN IN DRAWING 1399-03-01. EXTENT OF PATH TO BE DETERMINED ON SITE.

CROSSFALL (MIN.)	1:40
CROSSFALL (MAX.)	1:20
GRADES (MAX.)	2% FOR 450m 5% FOR 90m 10% FOR 30m



- CONCRTE PATHWAY DOSED WITH 22kg/m<sup>3</sup> POLYPROPYLENE FIBRES.
- 10mm WIDE EXPANSION JOINTS (FOAM FILLED WITH 10x10mm THIOFLEX TOPPING) 6m MAX. SPACING.
- "LOCK JOINT" CONTRACTION JOINTS 2m SPACING.

**TYPICAL FOOTPATH DETAIL  
TANTABIDDI TURNAROUND TO CAR PARK  
SCALE 1:20**



**GENERAL NOTES**



LEVEL 3  
20 TERRACE ROAD  
EAST PERTH WA 6004 AUSTRALIA  
TEL: 61 8 9326 0100  
FAX: 61 8 9326 0296

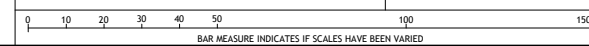
**SCALE:**

**AS MARKED @ A1**

UNLESS OTHERWISE STATED DIMENSIONS IN **mm**

**HORIZ:** EXM 94

**VERT:** AHD



DESIGNED	S.M
CHECKED	NS
DRAWN	S.O'B
CHECKED	S.M.
PROJECT MANAGER	N.S

APPROVED	
APPROVED	
APPROVED	
AUTHORISED	

**Department of Transport**

EXMOUTH  
TANTABIDDI BOAT RAMP - D.E.C. ADDITIONAL JETTY  
MISCELLANEOUS DETAILS

DRAWING NUMBER **1399 - 08 - 05**



REVN **A**

**Appendix C Existing Facility Dredging Design Drawings (URS 2015)**

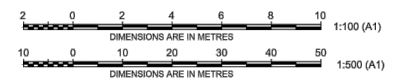
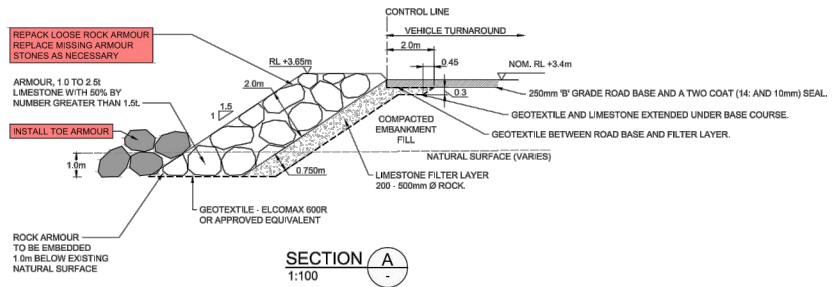
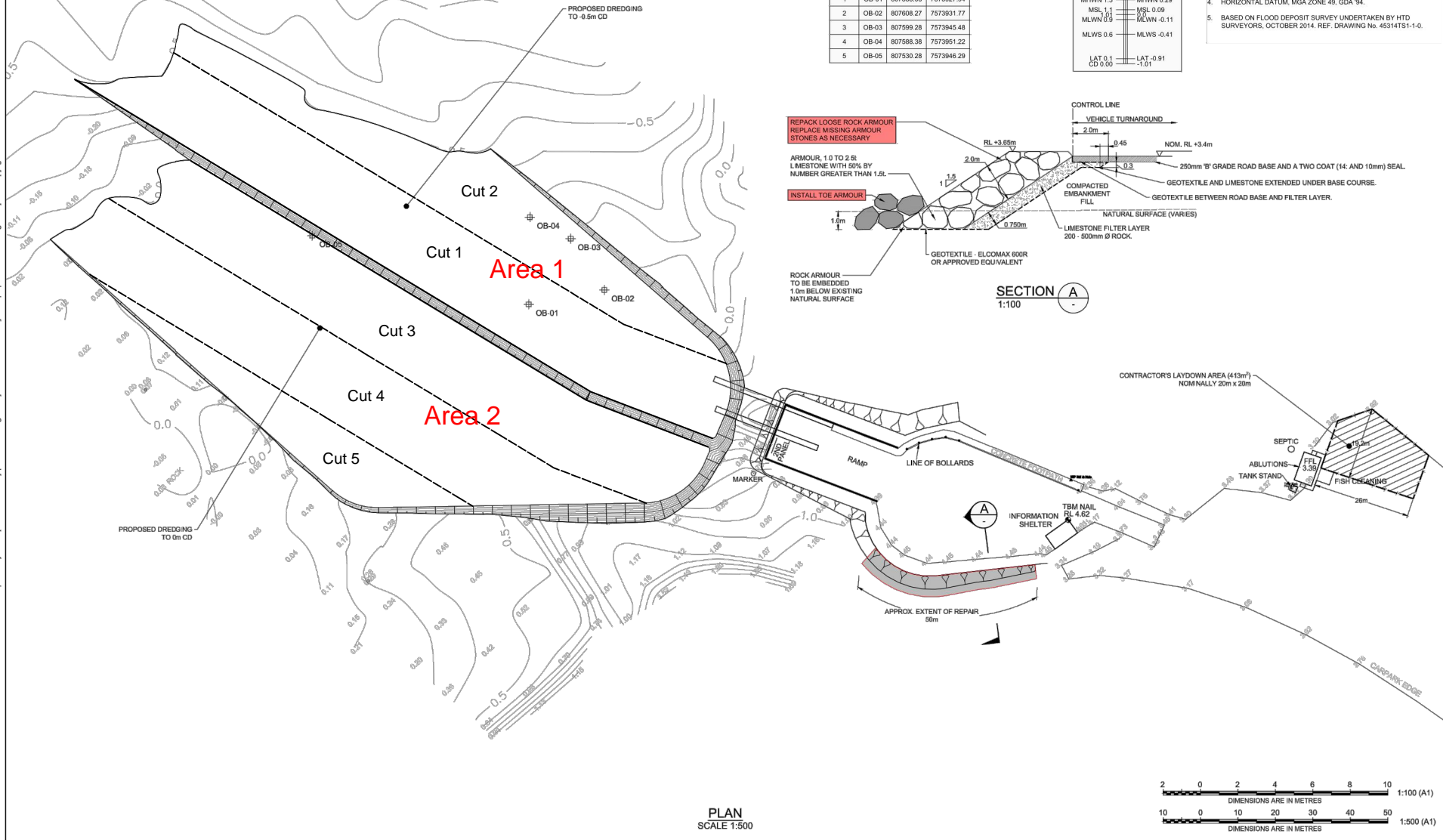
This design is based on generally accepted practices and standards at the time it was prepared. No other warranty, expressed or implied, is made. It is prepared in accordance with the scope of work and for the purpose outlined in the contract dated: DD-DEC-2014. No responsibility is accepted for use of any part of this design in any other context or for any other purpose. This drawing is subject to copyright.



Surveyed Obstructions Co-ords (Approximate)			
Point #	Ref.	Eastings	Northings
1	OB-01	807588.08	7573927.94
2	OB-02	807608.27	7573931.77
3	OB-03	807599.28	7573945.48
4	OB-04	807586.38	7573951.22
5	OB-05	807530.28	7573946.29

DATUM COMPARISON	
SOUNDING	A.H.D.
HAT 2.0	HAT 0.99
MHWS 1.6	MHWS 0.59
MHWN 1.3	MHWN 0.29
MSL 1.1	MSL 0.09
MLWN 0.9	MLWN -0.11
MLWS 0.6	MLWS -0.41
LAT 0.1	LAT -0.91
CD 0.00	-1.01

- NOTES:**
- DO NOT SCALE FROM THIS DRAWING.
  - ALL DIMENSIONS ARE IN METRES UNLESS NOTED OTHERWISE.
  - ALL LEVELS ARE IN METRES ABOVE CHART DATUM (CD) UNLESS NOTED OTHERWISE.
  - HORIZONTAL DATUM, MGA ZONE 49, GDA '94.
  - BASED ON FLOOD DEPOSIT SURVEY UNDERTAKEN BY HTD SURVEYORS, OCTOBER 2014. REF. DRAWING No. 45314TS1-1-0.

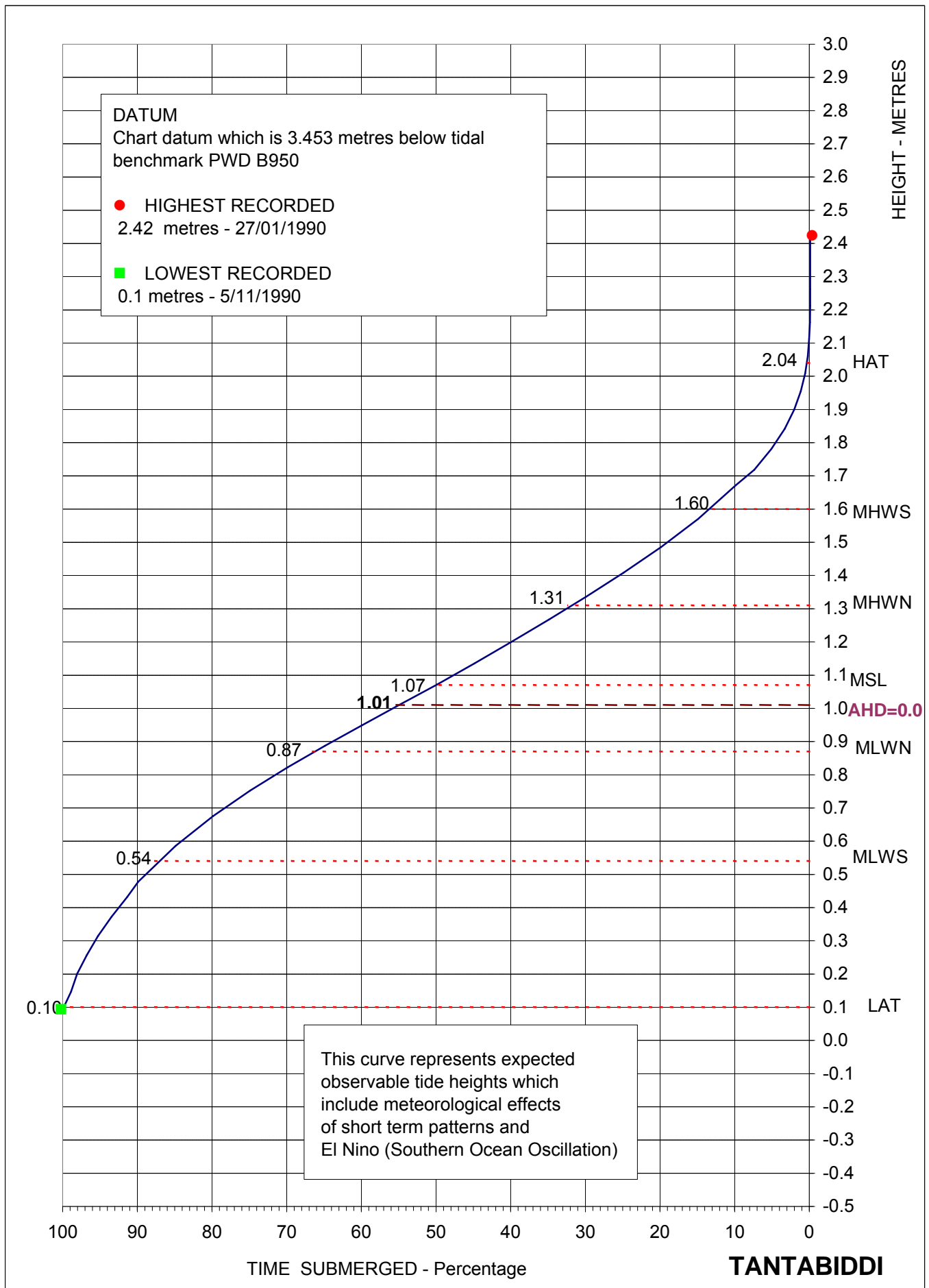


PLAN  
SCALE 1:500

					Sheet MA-003		 URS Australia Pty Ltd Level 4, EN House, 226 Adelaide Terrace, Perth 6000 Tel: +61 8 9326 0100 Fax: +61 8 9326 0296	 Shire of Exmouth <i>Open for business</i>	SAND BYPASSING TANTABIDDI		Status TENDER	
					Scales 1:500; 1:100 A1 1:1000; 1:200 A3				TANTABIDDI BOAT RAMP PROPOSED REMEDIAL WORKS GENERAL ARRANGEMENT PLAN & SECTION		Drawing Number 42908753-MA-003	
A	TENDER	NS	SOB	PJ	NS	11.02.15	Original Size	A1				
Rev	Revision Description	Designed	Drawn	Checked	Approved	Date						

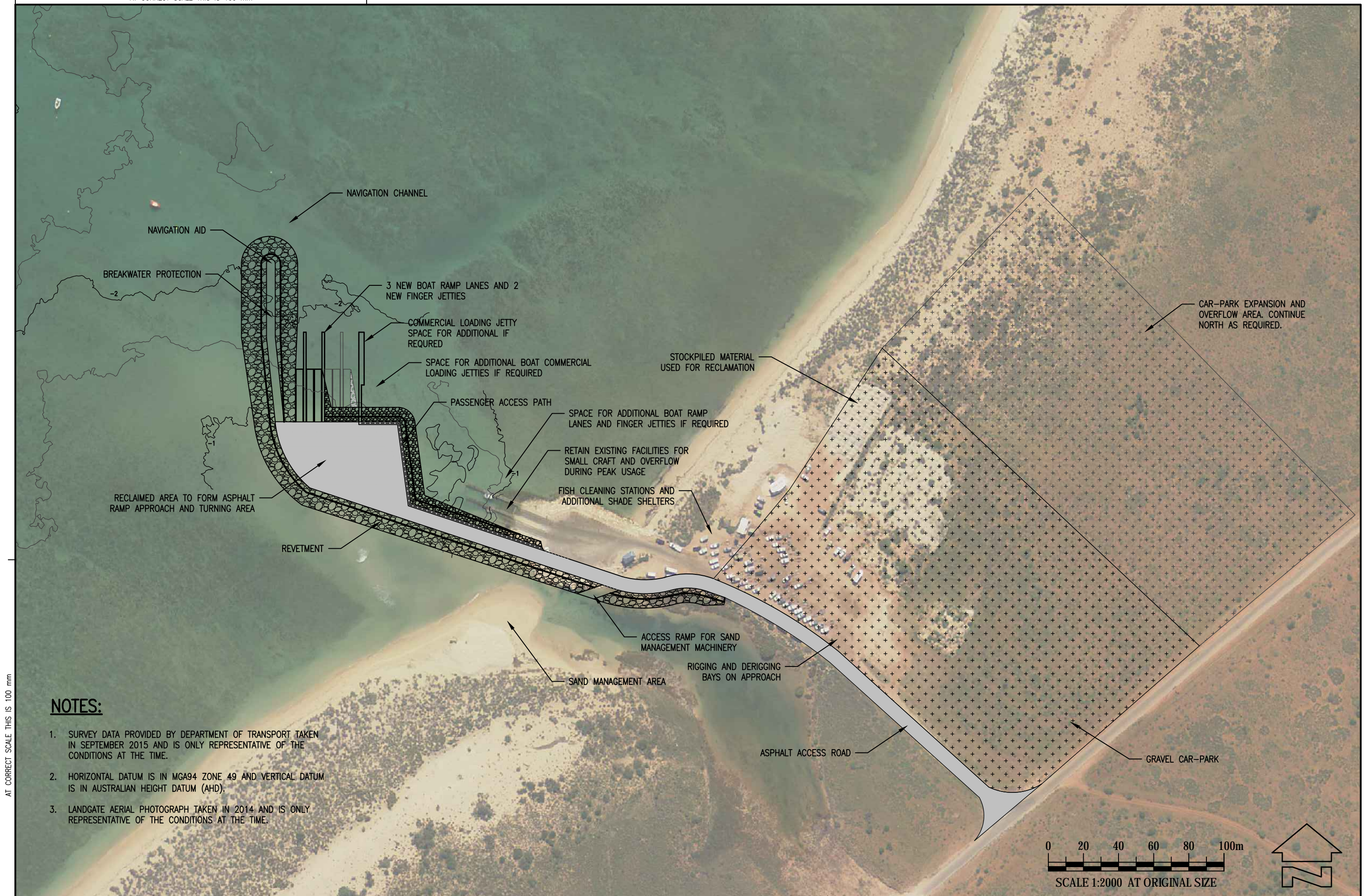
U:\Jobs\42908753\01.Working\42908753-MA-003.dwg Printed by: Shaun O'Brien 11-Feb-15

**Appendix D    Tantabiddi Submergence Curve (DoT 2012)**



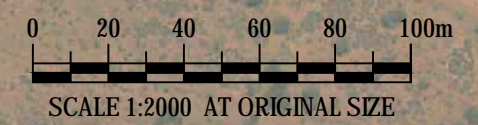
**Appendix E Long Term Expansion & Realignment Solution Sketch**

AT CORRECT SCALE THIS IS 100 mm



**NOTES:**

1. SURVEY DATA PROVIDED BY DEPARTMENT OF TRANSPORT TAKEN IN SEPTEMBER 2015 AND IS ONLY REPRESENTATIVE OF THE CONDITIONS AT THE TIME.
2. HORIZONTAL DATUM IS IN MGA94 ZONE 49 AND VERTICAL DATUM IS IN AUSTRALIAN HEIGHT DATUM (AHD).
3. LANDGATE AERIAL PHOTOGRAPH TAKEN IN 2014 AND IS ONLY REPRESENTATIVE OF THE CONDITIONS AT THE TIME.



AT CORRECT SCALE THIS IS 100 mm

<b>m p rogers &amp; associates pl</b> coastal and port engineers	Suite 1, 128 Main Street Osborne Park 6017 Western Australia	t: +61 8 9254 6600 f: +61 8 9254 6699 admin@coastsandports.com.au	DRAWN T HARDING	<b>RECOMMENDED SOLUTION</b> TANTABIDDI BOAT LAUNCHING FACILITY INVESTIGATION	SCALE AT A3 1:2,000	JUNE 2018 SK1514-01A
			CHECKED P DOUST		P:\MRA Poying Jobs\K1514 SoEx - Tantabiddi Boat Ramp\5 MRA Dwgs\Sketches\SK1514 Master	

m p rogers & associates pl

[www.coastsandports.com.au](http://www.coastsandports.com.au)

